

**TECHNICAL MANUAL
OPERATOR, UNIT, DIRECT SUPPORT,
AND GENERAL SUPPORT MAINTENANCE MANUAL
(INCLUDING REPAIR PARTS AND SPECIAL TOOLS LIST)
FOR
SPREADER, AGGREGATE: TOWED; 8 FT SPREAD
FF-8 (NSN 3895-01-329-5096)**

OPERATOR PMCS 2-3

**LUBRICATION
INSTRUCTIONS 3-1**

**OPERATOR
TROUBLESHOOTING
PROCEDURES 3-6**

UNIT PMCS 4-2

**UNIT TROUBLESHOOTING
PROCEDURES 4-4**

**PREPARATION FOR
OPERATION 4-9**

**MAINTENANCE
ALLOCATION CHART
(MAC) B-1**

**REPAIR PARTS AND
SPACIAL TOOLS LIST
(RPSTL) F-1**

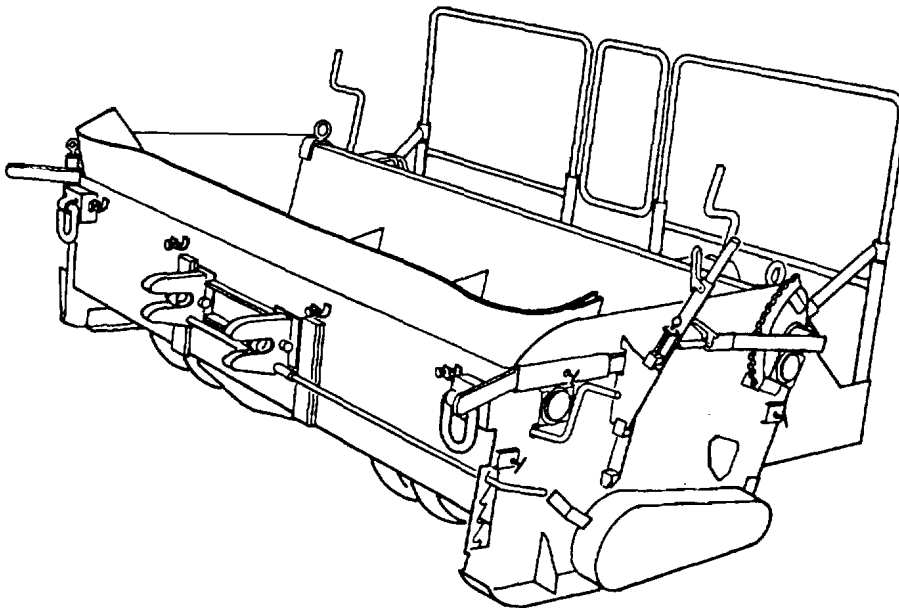

Approved for public release; distribution is unlimited

HEADQUARTERS, DEPARTMENT OF THE ARMY

20 APRIL 1992

FOR INFORMATION ON FIRST AID, REFER TO FM 21-11**WARNING**

Dry cleaning solvent P-D-680 is toxic and flammable. Wear protective goggles, face mask, and gloves and use in a well ventilated area. Avoid contact with skin, eyes, and clothes and do not breath vapors. Do not use near open flame or excessive heat. The flash point for Type I solvent is 100 degrees F (38 degrees C). The flash point for Type II solvent is 140 degrees F (60 degrees C). If you become dizzy while using cleaning solvent, get fresh air immediately and get medical aid. If contact with eyes is made, wash your eyes with water and get medical aid immediately.

WARNING

Do not stand between spreader and dump truck when dump truck is in motion. Ensure that dump truck has come to a complete stop before operating any spreader controls. Failure to follow this warning could result in severe injury or death.

WARNING

Ensure that both latches in coupler hitch lock onto shaft of truck hitch. If both latches do not lock onto truck hitch, spreader could break away from towing vehicle, causing severe injury or death to spreader operator.

WARNING

Ensure that both latches in coupler hitch release. If both latches do not release, spreader will move forward with dump truck. Failure to follow this warning could result in severe injury or death.

WARNING

Do not attempt to install inserts while feed roll or agitate or are turning. Any contact with moving agitator or feed roll could cause severe injury.

WARNING

Use a hand shovel to spread aggregate inside hopper. Spread from left to right only. Never use hands to cross feed material. Failure to follow this warning could result in injury.

WARNING

Spreader operator must wear protective face mask and respirator to avoid breathing stone dust. Failure to follow this warning could result in injury. Check with local medical and safety office to ensure proper equipment and fit.

WARNING

Spreader operator must wear respirator during hot bituminous tar chipping road resurfacing. Failure to follow this warning could cause injury or death. Check with local medical and safety office to ensure proper equipment and fit.

WARNING

Loose clothing can be caught in agitator and feed roll. Spreader operator must not wear loose clothing, open shirts, X4 length jacket or coat, or hanging scarf while operating spreader. Failure to follow this warning could result in severe injury or death

WARNING

Flying debris. Spreader operator must wear eye protection. Failure to follow this warning could result in eye injury or loss of vision. Check with local medical and safety office to ensure proper equipment and fit.

WARNING

Spreader operator must wear hearing protection. Failure to follow this warning could result in hearing loss or degradation. Check with local medical and safety office to ensure proper equipment and fit.

WARNING

Keep clear of equipment when it is being raised and lowered. Do not allow heavy components to swing while suspended by a lifting device. Exercise extreme caution when working near a cable under tension. Failure to follow this warning may result in severe injury or death to personnel.

WARNING

Dump truck driver must avoid sudden starts and stops. Failure to follow this warning could result in injury or death to spreader operator

WARNING

Spreader operator must wear steel toed shoes. Failure to follow this warning could result in injury. Check with local medical and safety office to ensure proper equipment and fit.

CHANGE
NO. 1

HEADQUARTERS
DEPARTMENT OF THE ARMY
Washington D.C., 20 April 1993

**OPERATOR'S, UNIT, DIRECT SUPPORT,
AND GENERAL SUPPORT MAINTENANCE MANUAL
(INCLUDING REPAIR PARTS AND SPECIAL TOOLS LISTS)**

**SPREADER, AGGREGATE: TOWED; 8 FT SPREAD
FF-8 (NSN 3895-01-329-5096
Current as of 13 November 1992**

TM 5-3895-367-14&P, dated 20 April 1992, is changed as follows:

1. Remove old pages and insert new pages as indicated below.
2. New or changed information is indicated by a asterisk or vertical bar in the margin of the page.

Remove Pages

1-3 and 1-4
3-1 through Figure 5
6-1 through Figure 10
11-1 through 16-2
17-1 and 17-2
18-1 through 20-1
I-1 through I-20

Insert Pages

1-3 and 1-4
3-1 through Figure 5
6-1 through Figure 10
11-1 through 16-2
17-1 and 17-2
18-1 through 20-1
I-1 through I-20

3. File this change sheet in front of the publication for reference purposes.

Approved for public release; distribution is unlimited.

By Order of the Secretary of the Army:

GORDON R. SULLIVAN
General, United States Army
Chief of Staff

Official:

Milton H. Hamilton
MILTON H. HAMILTON
Administrative Assistant to the
Secretary of the Army
04223

Distribution:

To be distributed in accordance with DA Form 12-25-E, Block 5262, requirements for TRIC-3825-230-14 & P.

**OPERATOR, UNIT, DIRECT SUPPORT,
AND GENERAL SUPPORT MAINTENANCE MANUAL
(INCLUDING REPAIR PARTS AND SPECIAL TOOLS LIST)
FOR
Spreader, Aggregate: Towed; 8 ft Spread
FF-8 (NSN 3895-01-329-5096)
Current as of 14 February 1992**

REPORTING ERRORS AND RECOMMENDING IMPROVEMENTS

You can help improve this manual. If you find any mistakes or if you know of a way to improve the procedures, please let us know. Mail your letter, DA Form 2028 (*Recommended Changes to Publications and Blank Forms*), or DA Form 2028-2, located in the back of this manual, direct to: Commander, U.S. Army Tank-Automotive Command, ATTN: AMSTA-MB, Warren, MI 48397-5000. A reply will be furnished to you.

TABLE OF CONTENTS

	Page
HOW TO USE THIS MANUAL	v
CHAPTER 1 INTRODUCTION	1-1
Section I. General Information	1-1
Section II. Equipment Description and Data	1-2
Section III. Technical Principles of Operation	1-6
CHAPTER 2 OPERATING INSTRUCTIONS	2-1
Section I. Description and Use of Operator's Controls and Indicators.....	2-2
Section II. Operator Preventive Maintenance Checks and Services (PMCS)	2-3
Section III. Operation Under Usual Conditions	2-7
Section IV. Operation Under Unusual Conditions	2-12
CHAPTER 3 OPERATOR MAINTENANCE	3-1
Section I. Lubrication Instructions	3-1
Section II. Operator Troubleshooting Procedures	3-6
CHAPTER 4 UNIT MAINTENANCE	4-1
Section I. Repair Parts; Special Tools; Test, Measurement, and Diagnostic Equipment (TMDE); and Support Equipment	4-2

Approved for public release, distribution is unlimited

TABLE OF CONTENTS (CONT)

	Illus/ Fig	Page
Section II. Unit Preventive Maintenance Checks and Services (PMCS)		4-2
Section III. Unit Troubleshooting Procedures		4-4
Section IV. Preparation for Operation		4-9
Section V. Unit Maintenance Procedures		4-31
Section VI. Preparation for Storage or Shipment		4-71
CHAPTER 5 DIRECT SUPPORT AND GENERAL SUPPORT MAINTENANCE		5-1
APPENDIX A REFERENCES		A-1
APPENDIX B MAINTENANCE ALLOCATION CHART		B-1
Section I. Introduction		B-1
Section II. Maintenance Allocation Chart		B-3
Section III. Tool and Test Equipment Requirements		B-6
Section IV. Remarks		B-6
APPENDIX C COMPONENTS OF END ITEM AND BASIC ISSUE ITEMS LISTS		C-1
Section I. Introduction		C-1
Section II. Components of End Item		(Not Applicable)
Section III. Basic Issue Items		C-2
APPENDIX D ADDITIONAL AUTHORIZATION LIST		D-1
APPENDIX E EXPENDABLE/DURABLE SUPPLIES AND MATERIALS LIST		E-1
Section I. Introduction		E-1
Section II. Expendable/Durable Supplies and Materials List		E-2
APPENDIX F REPAIR PARTS AND SPECIAL TOOLS LIST		F-1
Section I. Introduction		F-1
Section II. Repair Parts List		
GROUP 06 ELECTRICAL SYSTEM		
0609 LIGHTS		1-1
0613 TAILLIGHT ASSEMBLY	1	1-1
HULL OR CHASSIS WIRING HARNESS		2-1
MAIN BODY HARNESS	2	2-1
GROUP 11 REAR AXLE		
1100 REAR AXLE ASSEMBLY		3-1
AXLE ASSEMBLY (TRANSPORT) AND MOUNTING		
HARDWARE	3	3-1

TABLE OF CONTENTS (CONT)

		Illus/ Fig	Page
GROUP 13	WHEELS AND TRACKS		
1311 -	WHEEL ASSEMBLY		4-1
	TRANSPORT WHEEL AND HUB COMPONENTS	4	4-1
1313 -	TIRES, TUBES, TIRE CHAINS		5-1
	TIRES AND TUBES	5	
5-1			
GROUP 15	FRAME, TOWING ATTACHMENTS, DRAWBARS, AND ARTICULATION SYSTEMS		
1501 -	FRAME ASSEMBLY.....		6-1
	OPERATOR PLATFORM ASSEMBLY AND COMPONENTS	6	6-1
1503 -	PINTLES AND TOWING ATTACHMENTS		7-1
	TRANSPORT TONGUE COMPONENTS	7	7-1
	TRUCK HITCH COMPONENTS	8	8-1
	COUPLER HITCH ASSEMBLY AND RELATED PARTS	9	9-1
1507 -	LANDING GEAR, LEVELING JACKS		10-1
	LEVELING LEG ASSEMBLY	10	10-1
GROUP 22	BODY, CHASSIS, AND HULL ACCESSORY ITEMS		
2202 -	ACCESSORY ITEMS		11-1
	REFLECTOR, TOOLBOX, AND ACCESSORY ITEMS	11	11-1
2210 -	DATA PLATES AND INSTRUCTION HOLDERS		12-1
	DATA PLATES	12	12-1
GROUP 7	3CONCRETE AND ASPHALT EQUIPMENT COMPONENTS		
7303 -	CONTROLS		13-1
	CLUTCH SHIFT ARM AND FEED ROLL CONTROL LEVER		13
13-1			
	GATE CONTROL LEVER AND GATE ADJUSTMENT SCREW COMPONENTS	14	14-1
7304 -	HOPPERS, GATES, AND CHUTES		15-1
	HOPPER ASSEMBLY AND GATE RELATED COMPONENTS	15	15-1
7305 -	MAIN DRIVE		16-1
	GEARBOX ASSEMBLY	16	16-1
7309 -	VANE OR SCREW FEEDERS OR CONVEYORS		17-1
	AGITATOR ASSEMBLY AND RELATED PARTS	17	17-1
7311 -	FEEDING OR CONVEYOR SHAFT		18-1
	FEED ROLL AND RELATED PARTS	18	18-1
	BALANCE ROLLER AND RELATED PARTS	19	19-1
7315 -	TRACTION DRIVE		20-1
	TRACTION WHEEL ASSEMBLY AND RELATED PARTS ...	20	20-1
GROUP 95	GENERAL USE STANDARDIZED PARTS		
9501	-BULK MATERIEL		BULK-1
	BULK	BULK	BULK-1
Section III.	Special Tools List (Not Applicable)		
Section IV.	Cross-reference Indexes		
	NATIONAL STOCK NUMBER INDEX		I-1
	PART NUMBER INDEX1-5		
	FIGURE AND ITEM NUMBER INDEX		I-13

TABLE OF CONTENTS (CONT)

	Page
APPENDIX G ILLUSTRATED LIST OF MANUFACTURED ITEMS	G-1
Section I. Introduction	G-1
Section II. Manufactured Items Illustrations	G-1
APPENDIX H TORQUE SPECIFICATIONS	H-1
INDEX	Index-1

HOW TO USE THIS MANUAL

This manual contains all the Information you need to effectively operate and maintain the FF-8 aggregate spreader.

The front cover index will help you locate the most frequently used sections of the manual. If you need to find another section of the manual, check the table of contents. The table of contents lists each chapter, section, and appendix in the manual.

To find a specific paragraph, go to the first page in the chapter. Listed below the chapter title are the paragraph number, title, and starting page number for each paragraph in that chapter.

If you still can't find the information you need, check the index in the back of the manual. The index alphabetically lists every paragraph in the manual in a variety of ways. For example, "Transport Truck Axle Replacement" will

also be listed under "Axle" and "Replacement". The index tells you the page number where the task begins.

The directions "front", "back", "left", and "right" are always used as if the spreader were coupled to the dump truck and ready for use. The front of the spreader will always be where the coupler hitch is mounted, the rear of the spreader will always be where the operator's platform is mounted, the left side will always be the side with the gate control lever and clutch control lever, and the right side will always be the side where the leveling legs are installed.

Torque values within the maintenance procedures are based on clean, dry threads with torque being applied to existing capscrews or bolts. Refer to Appendix H for torque requirements for new capscrews or bolts and other exceptions to stated torque.

v/vi (blank)

**CHAPTER 1
INTRODUCTION**

Section I. GENERAL INFORMATION

	Page		Page
1-1 Scope	1-1	1-4 Destruction of Army Materiel to Prevent Enemy Use.....	1-2
1-2 Maintenance Forms, Records, and Reports	1-1	1-5 Preparation for Storage or Shipment.....	1-2
1-3 Reporting Equipment Improvement Recommendations (EIRs).....	1-2		

Section II. EQUIPMENT DESCRIPTION AND DATA

	Page		Page
1-6 Equipment Characteristics, Capabilities, and Features.....	1-2	1-8 Location and Content of Stencil Markings	1-5
1-7 Location and Description of Major Components.....	1-2	1-9 Equipment Data	1-5

Section III. TECHNICAL PRINCIPLES OF OPERATION

	Page		Page
1-10 Agitator.....	1-6	1-13 Traction Drive.....	1-6
1-11 Feed Roll.....	1-6	1-14 Coupler Hitch and Truck Hitch.....	1-6
1-12 Gearbox	1-6		

Section I. GENERAL INFORMATION

1-1. SCOPE.

a. *Type of Manual.* Operator, Unit, Direct Support, and General Support Maintenance Manual (Including Repair Parts and Special Tools List).

b. *Model Number and Equipment Name.* FF-8 Spreader, Aggregate:
Towed; 8 ft Spread.

c. *Purpose of Equipment.* Used to spread aggregate in widths between 4 and 8 ft. The spreader can be used with the following dump trucks:

Model No	NSN	Operator's TM
M51A2 (without winch)	2320-00-055-9262	TM 9-2320-211-10-1
M51A2 (with winch)	2320-00-055-9263	TM 9-2320-211-10-1
M817 (without winch)	2320-00-050-8970	TM 9-2320-260-10
M817 (with winch)	2320-00-051-0589	TM 9-2320-260-10

Model No	NSN	Operator's TM
M929	2320-01-047-8756	TM 9-2320-272-10
M929A1	2320-01-206-4079	TM 9-2320-272-10
M929A2	2320-01-230-0305	TM 9-2320-272-10
M930	2320-01-047-8755	TM 9-2320-272-10
M930A1	2320-01-206-4080	TM 9-2320-272-10
M930A2	2320-01-230-0306	TM 9-2320-272-10

Always refer to the applicable operator's TM when instructed to operate the dump truck.

d. *Special Limitations on Equipment.* The maximum operating speed of the spreader is 5 mph (8 kph). Do not use the spreader to spread sand.

1-2. MAINTENANCE FORMS, RECORDS, AND REPORTS.

Department of the Army forms and procedures used for equipment maintenance will be those prescribed by DA Pam 738-750, *The Army Maintenance Management System (TAMMS)*.

1-3. REPORTING EQUIPMENT IMPROVEMENT RECOMMENDATIONS (EIRs).

If your spreader needs Improvement, let us know. Send us an EIR. You, the user, are the only one who can tell us what you don't like about your equipment. Let us know why you don't like the design or performance. Put it on an SF 368 (Product Quality Deficiency Report). Mail it to us at Commander, U.S. Army Tank-Automotive Command, ATTN: AMSTA-QRD, Warren, MI 48397-5000. We'll send you a reply.

1-4. DESTRUCTION OF ARMY MATERIEL TO PREVENT ENEMY USE.

Refer to TM 750-244-6, Procedures for Destruction of Tank-Automotive Equipment to Prevent Enemy Use.

1-5. PREPARATION FOR STORAGE OR SHIPMENT.

Refer to Chapter 4, Section VI for procedures for preparing the spreader for storage or shipment.

Section II. EQUIPMENT DESCRIPTION AND DATA

1-6. EQUIPMENT CHARACTERISTICS, CAPABILITIES, AND FEATURES.

a. *Characteristics.* The spreader described in this manual is non-metric and does not require metric common or special tools; therefore, metric units are not supplied.

b. *Capabilities and Features.*

- (1) Can spread aggregate in widths between 4 and 8 ft
- (2) Can operate in forward and reverse directions at a maximum speed of 5 mph (8 kph)
- (3) Can be transported short distances while coupled to dump truck
- (4) Removable transport truck and tongue allows spreader to be towed long distances at a maximum speed of 40 mph (64 kph)
- (5) Can spread between 1 and 106 lb of aggregate per sq yd
- (6) Aggregate spread can be flat or tapered

1-7. LOCATION AND DESCRIPTION OF MAJOR COMPONENTS.

HOPPER (1). Receives aggregate from towing vehicle. Inserts can be inserted into hopper to vary width of spread from 8 to 4 ft.

OPERATOR'S PLATFORM (2). Provides stable surface from which operator can monitor flow of aggregate.

AGITATOR (3). Located at bottom of hopper. Distributes aggregate from hopper to feed roll.

GEARBOX (4). Contains the clutch, shafts, and gears that engage and disengage the feed roll.

TRACTION WHEELS (5). Roll along road bed. Provide power to operate agitator and feed roll.

FEED ROLL (6). Located beneath agitator. Spreads aggregate evenly on the ground to the desired depth.

COUPLER HITCH (7). Latches onto hitch mounted on dump truck so that dump truck can pull spreader.

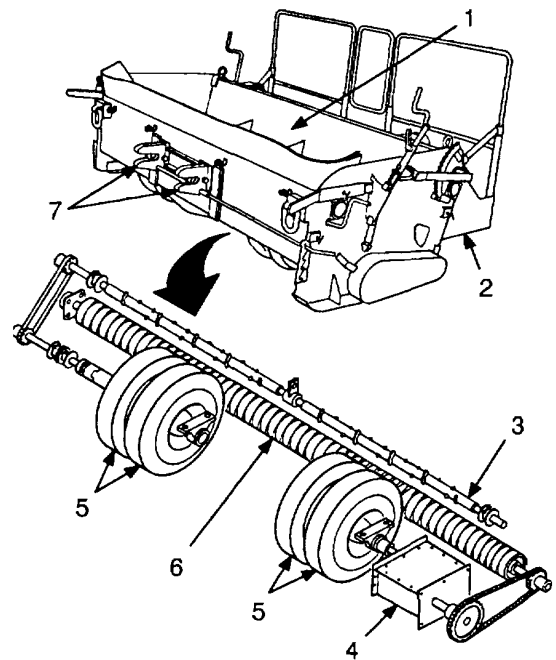

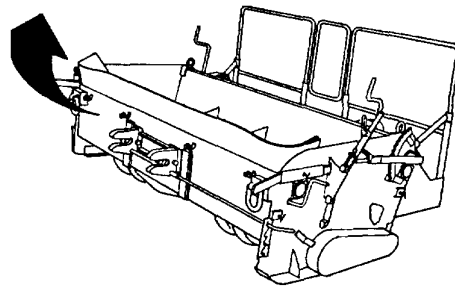
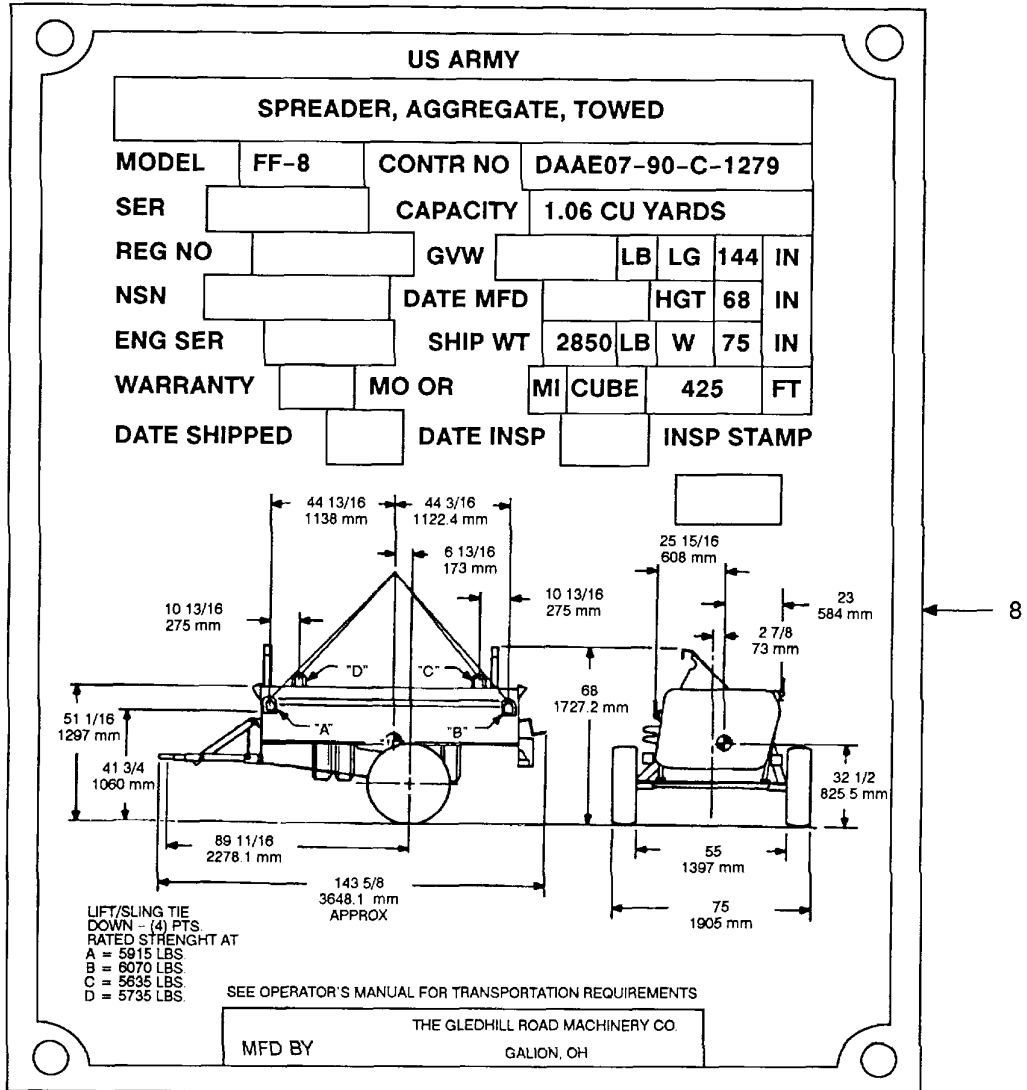

IDENTIFICATION AND TRANSPORT PLATE (8). Lists equipment data and transport dimensions.

1-7. LOCATION AND DESCRIPTION OF MAJOR COMPONENTS (CONT)

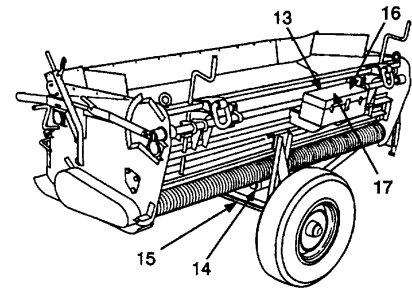
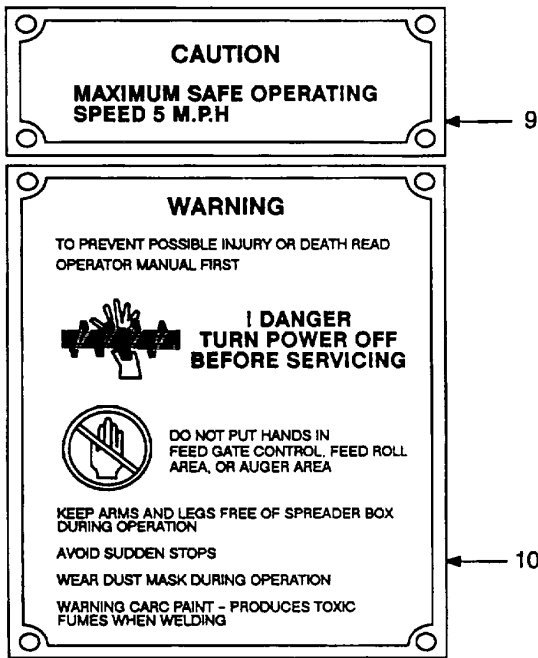

WARNING DECAL (16). Caution hearing protection required.
 WARNING DECAL (17). Danger eye protection required.

TOOL BOX (13). Stowage for basic Issue Items.

BALANCE ROLLER (14). Prevents spreader from tipping over onto feed roll. Provides some mobility when positioning spreader manually.

TRANSPORT TRUCK (15). Installed for long distance travel.

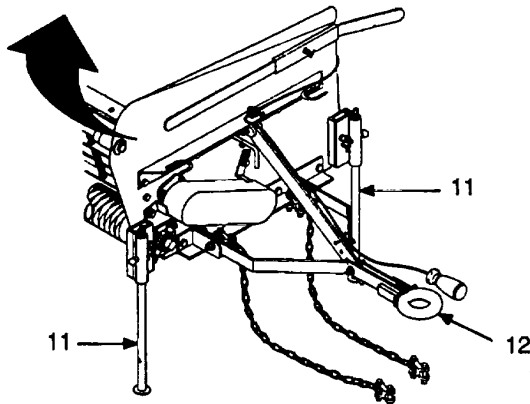

CAUTION DATA PLATE (9). For operator safety and effective spreading, spreader must never be operated over 5 mph (8 kph).

WARNING DATA PLATE (10). Lists warnings applicable to operation and maintenance of the spreader.

LEVELING LEGS (11). Support front of hopper when spreader is installed on transport truck.

TRANSPORT TONGUE (12). Installed for long distance travel; removed for normal operation. Drawbar connects to towing vehicle pintle.

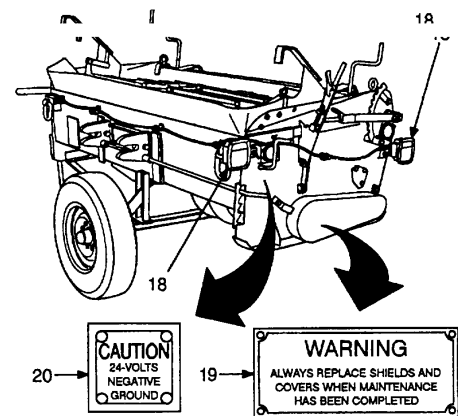

TAILLIGHTS (18). Installed when spreader is mounted on transport truck. Provide brake lights and turn signals.

SHIELDS AND COVERS WARNING PLATE (19). For operator and maintainer safety, chain guards must always be installed. Plate is Installed on both chain covers.

24-VOLTS CAUTION PLATE (20). Spreader taillights can only be used with a 24-volt, negative ground power source.

1-8. LOCATION AND CONTENT OF STENCIL MARKINGS.

The following illustrations show the location and contents of all stencil markings.

Maintain all stencil markings so that the information remains legible. If any stencil marking is illegible, notify unit maintenance.

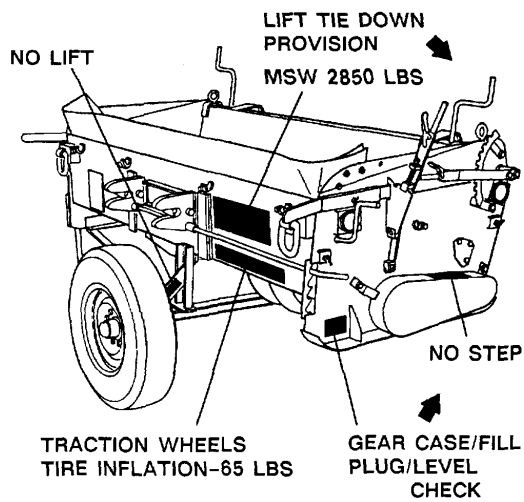
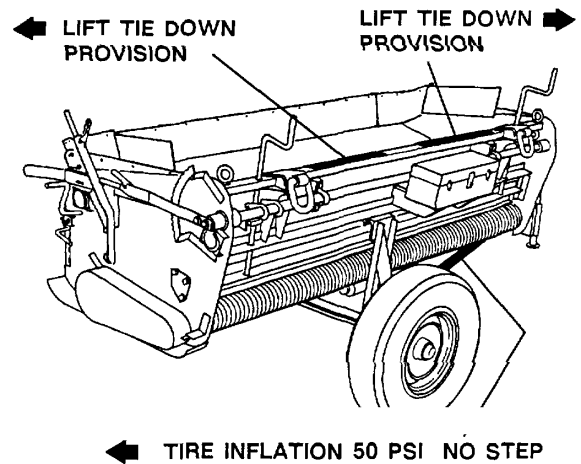
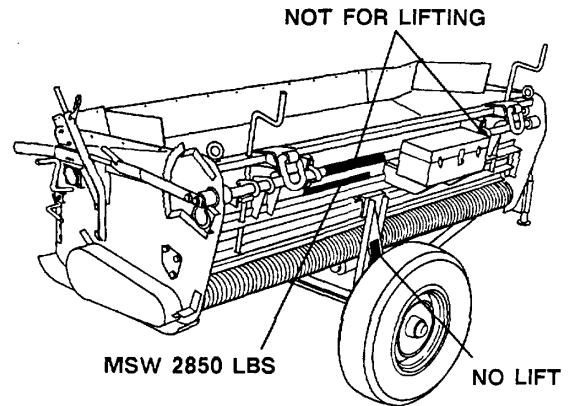
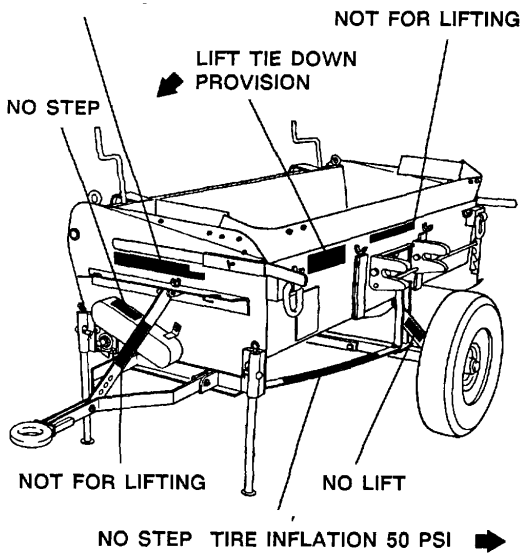

1-9. EQUIPMENT DATA.

Dimensions (approximate)

Operational configuration

- Length 71 in.
- Width 111 5/8 in.
- Height 577/16 in.

Transport configuration

- Length 143 5/8 in.
- Width 75 in.
- Height 68 in.
- Ground clearance 14 X in.

Shipping weight 2850lb

Hopper capacity 1.06 cu yd

Tires:

Transport truck

- Type LT235/85R16 M/S
- Inflation pressure 50 psi

Traction drive

- Type 6.90 x 15, 6 ply
- Inflation pressure 65 psi

Section III. TECHNICAL PRINCIPLES OF OPERATION

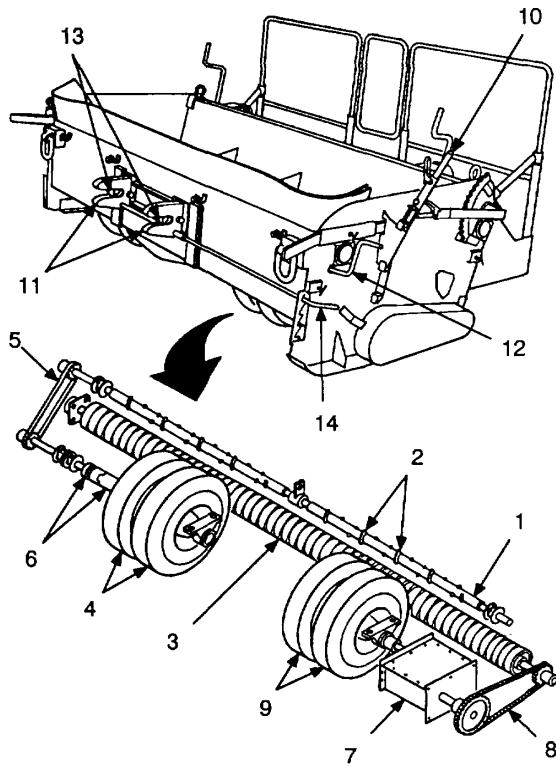

speed as the towing vehicle is moving. The feed roll is driven by the gearbox (7) by a chain (8) and two sprockets. Grooves in the feed roll catch the aggregate and distribute it on the road bed.

1-12. GEARBOX.

The gears in the gearbox (7) are directly driven by the left-hand traction drive wheels (9) by a coupling and shaft. Gears inside the gearbox ensure that the feed roll (3) always rotates in the same direction, whether the spreader is traveling forward or backward. A slip clutch inside the gearbox automatically disengages the feed roll if the feed roll control lever (10) is set for the wrong direction.

1-13. TRACTION DRIVE.

The traction drive wheels (4 and 9) roll along the road bed and provide the mechanical motion that drives the agitator (1) and feed roll (3). A coupling and shaft on the left set of traction drive wheels drive the gearbox (7), which in turn drives the feed roll through a chain (8) and two sprockets. A clutch on the right set of traction drive wheels drives the agitator through a chain (5) and two sprockets.

1-14. COUPLER HITCH AND TRUCK HITCH.

The truck hitch is mounted on the back of the dump truck. The coupler hitch (11) is mounted on the front of the spreader. A crank (12) raises and lowers the coupler hitch by opening and closing a set of pantograph links, allowing the spreader to be used with a variety of dump trucks of differing heights. Dogs (13) inside the coupler hitch housing latch onto the truck hitch. A spring-loaded latch lever (14) opens the dogs inside the coupler hitch housing, allowing the spreader to be coupled and uncoupled.

1-10. AGITATOR.

With the clutch engaged and the spreader and towing vehicle moving, the agitator (1) rotates at the same speed and in the same direction as the towing vehicle is moving. Right-hand and left-hand vanes (2) welded to the agitator evenly distribute the aggregate to the feed roll (3). The agitator is directly driven by the right-hand traction drive wheels (4) by a chain (5) and two sprockets. A control handle on the right side of the hopper engages and disengages the clutch (6) that drives the agitator.

1-11. FEED ROLL.

With the clutch engaged and the spreader and towing vehicle moving, the feed roll (3) rotates at the same

**CHAPTER 2
OPERATING INSTRUCTIONS**

Section I. DESCRIPTION AND USE OF OPERATOR’S CONTROLS AND INDICATORS

	Page
2-1 Controls and Indicators	2-2

Section II. OPERATOR PREVENTIVE MAINTENANCE CHECKS AND SERVICES (PMCS)

	Page		Page
2-2. General.....	2-3	2-4. Explanation of Columns	2-4
2-3. PMCS Procedures	2-4	2-5. Leakage Definitions	2-4

Section III. OPERATION UNDER USUAL CONDITIONS

	Page		Page
2-6 Spreading Aggregate	2-7	2-8 Operating Instructions on Decals and Instruction Plates.....	2-11
2-7 Preparation for Movement.....	2-9		

Section IV. OPERATION UNDER UNUSUAL CONDITIONS

	Page		Page
2-9. Operation in Extreme Cold.....	2-12	2-12. Operation in Sandy or Dusty Areas.....	2-12
2-10. Operation in Extreme Heat and High Humidity	2-12	2-13. Operation in Saltwater Areas.....	2-12
2-11. Operation In Snow and Mud.....	2-12	2-14. Fording.....	2-12

Section I. DESCRIPTION AND USE OF OPERATOR'S CONTROLS AND INDICATORS

2-1. CONTROLS AND INDICATORS.

This section lists and describes each of the controls and indicators required to operate the spreader. Learn how each control operates before using the spreader.

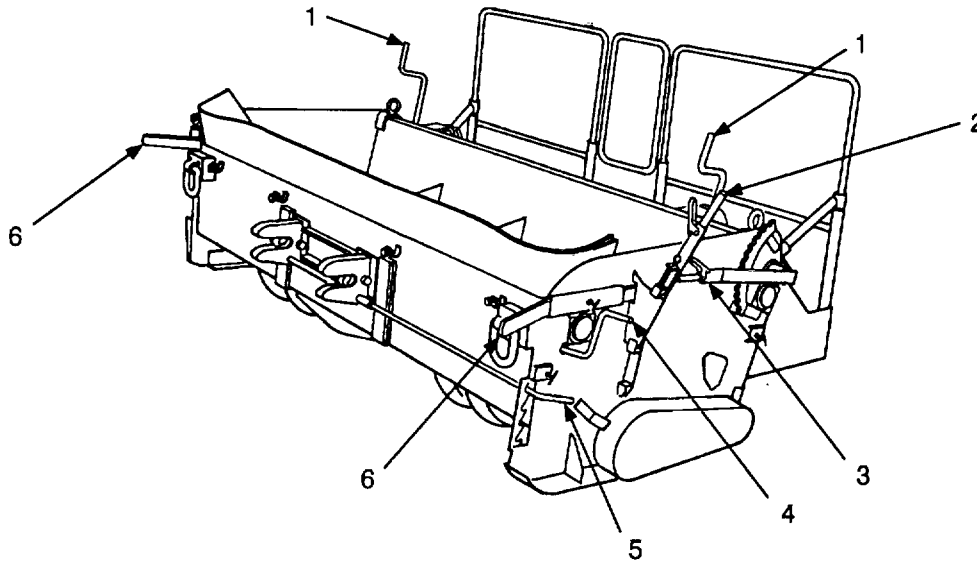

Key	Control/Indicator	Function
1	Gate adjusting screws	Used for fine adjustments of the gate assembly. Screws can be set individually to taper the spread. Turn screws counterclockwise to open the gate, clockwise to close the gate.
2	Feed roll control lever	Engages or disengages feed roll. Towing vehicle and spreader must be stopped before changing setting of feed roll control lever. To operate spreader in a forward direction, set feed roll control lever to FORWARD SPREAD. To operate spreader in backward direction, set feed roll control lever to REVERSE SPREAD.
3	Gate adjusting lever	Opens and closes gate assembly. Lever has 15 lever positions. Maximum gate opening is 5 in.
4	Hitch adjusting crank	Raises and lowers coupler hitch.
5	Latch lever	Used to engage and disengage coupler hitch from truck hitch. Rotate latch lever upward to open coupler hitch. Latch lever is spring loaded and will return to closed position.
6	Balancing handles (two)	Used to balance and position spreader. Unscrew thumbscrew and slide handle out of guide. When spreader is positioned, slide handle into guide and tighten thumbscrew.

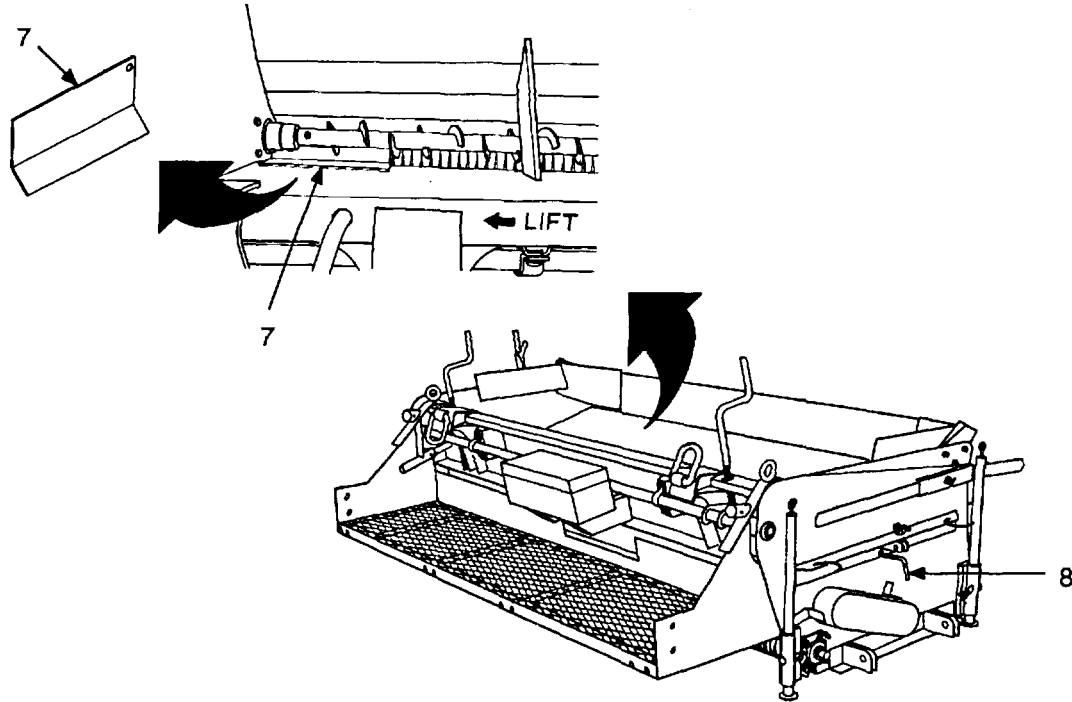

Key	Control/Indicator	Function
<p>NOTE For clarity, operator's platform is shown with rails and gate removed. Never operate spreader unless rails and gate are installed.</p>		
7	Inserts	Inserted into hopper to vary width of spread. Hopper must be empty, clutch control lever must be set to NEUTRAL, and towing vehicle and spreader must be stopped before inserting inserts.
8	Agitator clutch control lever	Used to engage or disengage agitator. Pull lever out to engage agitator, push lever in to disengage agitator.

Section II. OPERATOR PREVENTIVE MAINTENANCE CHECKS AND SERVICES (PMCS)

2-2. GENERAL PMCS INFORMATION.

a. *Before You Operate.* Always keep in mind the WARNINGS and CAUTIONS. Perform your before (B) PMCS prior to the equipment leaving its containment area or performing its intended mission.

b. *While You Operate.* Always keep in mind the WARNING s and CAUTIONS. Perform your during (D) PMCS when the equipment is being used in its intended mission.

c. *After You Operate.* Be sure to perform your after (A) PMCS after the equipment has been taken out of its mission mode or returned to its containment area.

d. *If Your Equipment Fails to Operate.* Troubleshoot with proper equipment. Report any deficiencies using the proper forms. See DA Pam 738-750.

2-3. PMCS PROCEDURES.

Your PMCS table lists the Inspections and care required to keep your equipment in good operating condition.

If your equipment does not perform as required, refer to troubleshooting procedures in Chapter 3. Report any malfunctions or failures on DA Form 2404 or refer to DA Pam 738-750.

2-4. EXPLANATION OF COLUMNS.

a. *Item No.* This column lists a logical order for performing PMCS. Use the number in this column as the "TM Item No." on DA Form 2404, Equipment Inspection and Maintenance Worksheet, when recording the results of PMCS.

b. *Interval.* The dot in this column tells you when to do a certain check or service.

c. *Item to be Inspected.* This column lists the portion of the equipment to be inspected and the specific item being inspected.

d. *Procedures.* This column tells you how to do the required checks and services. Carefully follow these instructions. If you do not have the tools, or if the procedures tell you to, have unit maintenance do the task.

NOTE

The terms "ready/available" and "mission capable" refer to the same status: equipment is on hand and is able to perform its combat missions (see AR 700-138).

e. Equipment is Not Ready/Available If This column tells you when and why your equipment cannot be used.

2-5. LEAKAGE DEFINITIONS.

It is necessary for you to know how fluid leakage affects the status of your equipment. The following are definitions of the types/classes of leakage you need to know to be able to determine the status of your spreader.

Leakage Definitions for Operator PMCS

Class I	Seepage of fluid (as indicated by wetness or discoloration) not great enough to form drops.
Class II	Leakage of fluid great enough to form drops, but not great enough to cause drops to drip from the item being inspected.
Class III	Leakage of fluid great enough to form drops that fall from the item being inspected.

CAUTION

Equipment operation is allowed with minor leakage (Class I or II). Of course, you must consider the fluid capacity in the item/system being checked/inspected. When in doubt, notify your supervisor.

When operating with Class I or II leaks, continue to check fluid levels as required in your PMCS.

Report Class II leaks to your supervisor or unit maintenance.

Table 2-1. OPERATOR PREVENTIVE MAINTENANCE CHECKS AND SERVICES (PMCS)

B-Before			D- During		A-After	
ITEM NO.	INTERVAL			ITEM TO BE INSPECTED	PROCEDURE CHECK FOR AND HAVE REPAIRED, FILLED OR ADJUSTED ASNEEDED	EQUIPMENT IS NOT READY/ AVAILABLE IF:
	B	D	A			
					<p>NOTE Perform weekly as well as before operation PMCS if:</p> <p>a. You are the assigned operator but have not operated the equipment since the last weekly.</p> <p>b. You are operating the equipment for the first time.</p>	
1	•	Tires		TRANSPORT TRUCK	<p>a. Check tires for obvious damage such as cuts, bruises, bulges, and flats</p> <p>b. Check tires for foreign objects imbedded in treads or unusual wear. Remove any stones from between treads.</p>	Tires damaged or un-serviceable.
2	•			Wheels	Check for bent wheels. Check wheel nuts for signs of looseness. One or more wheel nuts loose or missing.	One wheel damaged.
3	•			TRANSPORT TONGUE AND SAFETY CHAINS Drawbar	Check drawbar for secure mounting and obvious damage	Drawbar missing, loose, or damaged.
4	•			Safety Chains	Check safety chains for secure mounting and obvious damage	Safety chain missing, loose, or broken.
5	•			TRANSPORT LIGHTS Wiring	<p>a. Inspect intervehicular cable connector plug for damage.</p> <p>b. Inspect pins for dirt, bends, burns, or damage.</p> <p>c. Inspect wiring harness for signs of damage.</p>	
6	•			Lights	Connect intervehicular cable to towing vehicle and check operation of lights.	Lights do not work.

Table 2-1. OPERATOR PREVENTIVE MAINTENANCE CHECKS AND SERVICES (PMCS) (CONT)

B-Before

D- During

A-After

ITEM NO.	INTERVAL			ITEM TO BE INSPECTED	PROCEDURE CHECK FOR AND HAVE REPAIRED, FILLED OR ADJUSTED AS NEEDED	EQUIPMENT IS NOT READY/ AVAILABLE IF:
	B	D	A			
7	•			SPREADER Traction Tires	a. Check tires for obvious damage such as cuts, bruises, bulges, and flats (para 1-7). b. Check tires for foreign objects imbedded in treads or unusual wear. Remove any stones from between treads.	Tires damaged or un-serviceable.
8	•			Wheels	Check for bent wheels. Check wheel nuts for signs of looseness.	One wheel damaged. One or more wheel nuts loose or missing.
9	•			Reflectors	Check for damaged or missing reflectors.	Any control is obviously damaged.
10	•			Controls	a. Check gate adjusting lever, gate adjusting screws, feed roll control lever, agitator clutch control lever, and hitch adjusting crank for obvious damage. b. Check controls for proper operation (para 2-1). Controls should operate smoothly and without binding.	
		•				
11	•			Coupler Hitch	a. Check that coupler hitch height can be adjusted. b. Check that coupler hitch opens and closes fully.	Coupler hitch height cannot be adjusted. Coupler hitch does not open or close fully.
12	•			Gearbox	Check gearbox for signs of leakage. Check for proper oil level (Chapter 3, Section I).	Evidence of Class II leakage.
13	•			Operator's Platform	a. Check for completeness. Stowed in operator's platform should be both post and frame assemblies, shovel, spacers, truck hitch, and chute. b. Check operator's platform for cracks, breaks, or other damage. Ensure that gate can be latched closed.	Any listed component missing. Operator's platform damaged. Gate cannot be latched closed.
14	•			Truck Hitch	Inspect for cracks, breaks, or other damage. damaged.	Truck hitch missing or
15	•			Feed Roll and Agitator Drive Chains	Check for presence of drive chains.	Either drive chain missing.

Section III. OPERATION UNDER USUAL CONDITIONS

2-6. SPREADING AGGREGATE.

a. Have unit maintenance do the following:

- (1) Remove taillights (para 4-11).
- (2) Remove transport truck and tongue (para 4-12).
- (3) Install truck hitch on dump truck (para 4-13).
- (4) Install operator's platform on spreader (para 4-14).
- (5) Couple spreader to dump truck (para 4-15).

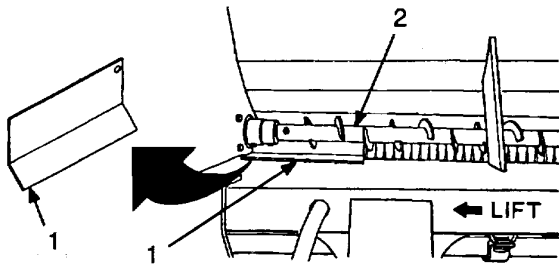

WARNING

Do not attempt to install inserts while feed roll or agitator are turning. Any contact with moving agitator or feed roll could cause severe injury.

b. If necessary, remove inserts (1) from spreader toolbox and install under agitator (2) to reduce width of spread.

c. Ensure that truck tailgate clears the spreader so that flow of aggregate will be smooth.

WARNING

- **Spreader operator must wear protective face mask and respirator to avoid breathing stone dust. Failure to follow this warning could result in injury. Check with local medical and safety office to ensure proper equipment and fit.**

- **Spreader operator must wear respirator during hot bituminous tar chipping road resurfacing. Failure to follow this warning could result in injury**

or death. Check with local medical and safety office to ensure proper equipment and fit.

- Loose clothing can be caught in agitator and feed roll. Spreader operator must not wear loose clothing, open shirts, Y length jacket or coat, or hanging scarf while operating spreader. Failure to follow this warning could result in severe injury or death.
- Flying debris. Spreader operator must wear eye protection. Failure to follow this warning could result in eye injury or loss of vision. Check with local medical and safety office to ensure proper equipment and fit.
- Spreader operator must wear hearing protection. Failure to follow this warning could result in hearing loss or degradation. Check with local medical and safety office to ensure proper equipment and fit.
- Spreader operator must wear steel toed shoes. Failure to follow this warning could result in injury. Check with local medical and safety office to ensure proper equipment and fit.

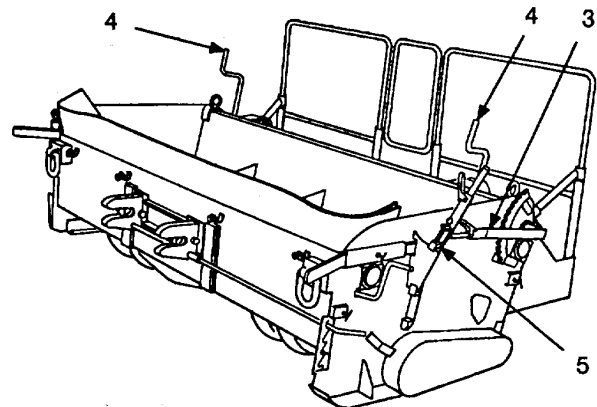

d. Set gate adjusting lever (3) for desired flow of aggregate.

e. Use gate adjusting screws (4) to make fine adjustments to aggregate flow. Gate adjusting screws can be set separately for a tapered spread.

f. To operate spreader in a forward direction, set feed roll control lever (5) to FORWARD SPREAD. To operate spreader in a backward direction, set feed roll control lever to REVERSE SPREAD. To change setting of feed roll control lever, dump truck and spreader must be completely stopped.

2-6. SPREADING AGGREGATE (Cont)

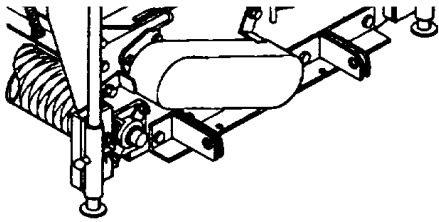

g. Pull out agitator clutch control (6) lever to engage agitator. It may be necessary to slowly move spreader to engage agitator.

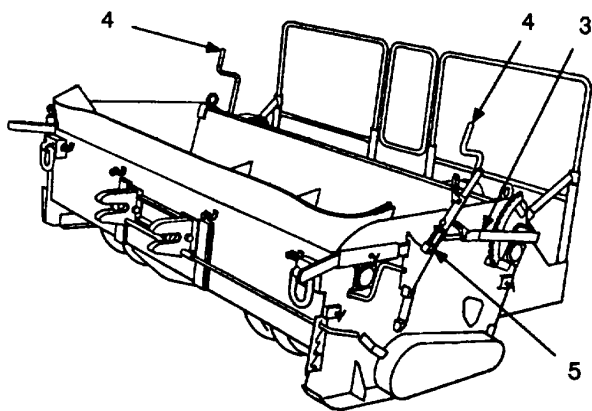

WARNING

Dump truck driver must avoid sudden starts and stops. Failure to follow this warning could result in injury or death to spreader operator.

h. Drive forward or reverse and raise the dump truck bed. Aggregate will pass overfeed roll onto the ground. If

feed roll control lever (5) is not properly set for direction of travel, clutch will automatically disengage.

i. Normal operating speed of spreader is between 3 and 5 mph (5 and 8 kph). This speed will vary with the type of material being spread, the thickness of the spread, and the condition of the area being covered. Once started, a steady speed must be maintained to ensure an even flow of aggregate.

WARNING

Use a hand shovel to spread aggregate inside hopper. Never use hands to cross feed material. Failure to follow this warning could result in injury.

j. Spreader operator should monitor flow of aggregate from dump truck into hopper. If flow of aggregate into hopper is uneven, use a hand shovel to even the flow.

k. When finished spreading aggregate, do the following:

- (1) Come to a complete stop.
- (2) Close gate using gate adjusting lever (3).
- (3) Set feed roll control lever (5) to NEUTRAL to disengage feed roll.

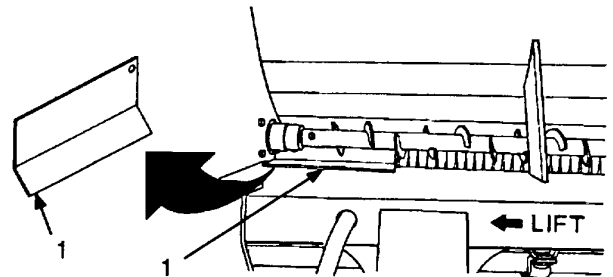

- (4) Push in agitator clutch control lever (6) to disengage agitator.
- (5) If necessary, remove inserts (1) from hopper and stow in spreader toolbox.
- (6) Prepare spreader for short move or long move as appropriate (para 2-7)

2-7. PREPARATION FOR MOVEMENT.

a. Introduction. The spreader can be moved short distances off-road, within the job site, while still coupled to the dump truck. Follow paragraph b below. If spreader is to be moved long distances over the highway, it must be installed on transport truck. Follow paragraph c below.

b. Short Move. The spreader can be moved short distances while still coupled to the dump truck. Proceed as follows:

- (1) Raise dump body about 1/3.

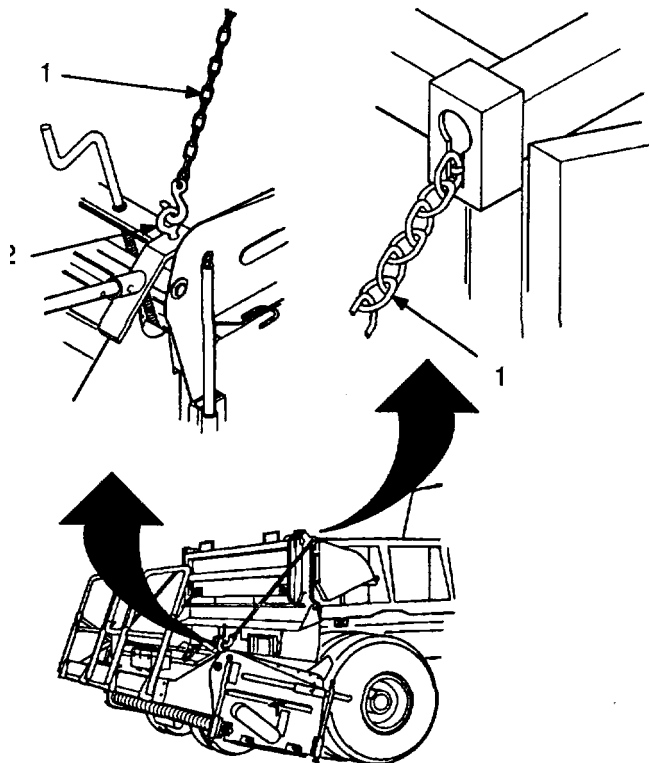

- (2) Remove chains (1) from spreader toolbox.
- (3) Connect chains (1) to hopper eyebolts (2).

- (4) Feed other end of chains (1) through retaining holes in dump truck tailgate. The same number of links must be fed through both retaining holes.
- (5) Lower dump body. Spreader will clear the ground sufficiently to allow travel. If ground clearance is insufficient, proceed as follows:
 - (a) Raise dump body about M.
 - (b) Feed several more chain links through retaining holes.
 - (c) Lower dump body and check ground clearance.
 - (d) Repeat steps (a) through (c) until ground clearance is sufficient to permit travel.
- (6) After travel, raise dump body until spreader is resting on ground. Unhook chains (1) from chain retaining holes and hopper eyebolts (2). Stow chains in spreader toolbox.

c. Long Move. The spreader can be towed long distances at a maximum speed of 40 mph (64 kph) by any vehicle capable of towing 2850 lb and equipped with a towing pintle and a 24-volt, 12-contact intervehicular cable connector. Proceed as follows:

- (1) Have unit maintenance do the following:
 - (a) Uncouple spreader from dump truck (para 4-15).
 - (b) Remove truck hitch from dump truck (para 4-13).
 - (c) Remove operator's platform from spreader (para 4-14).
 - (d) Install transport truck and tongue on spreader (para 4-12).
 - (e) Install taillights on spreader (para 4-11).

2-7. PREPARATION FOR MOVEMENT (CONT).

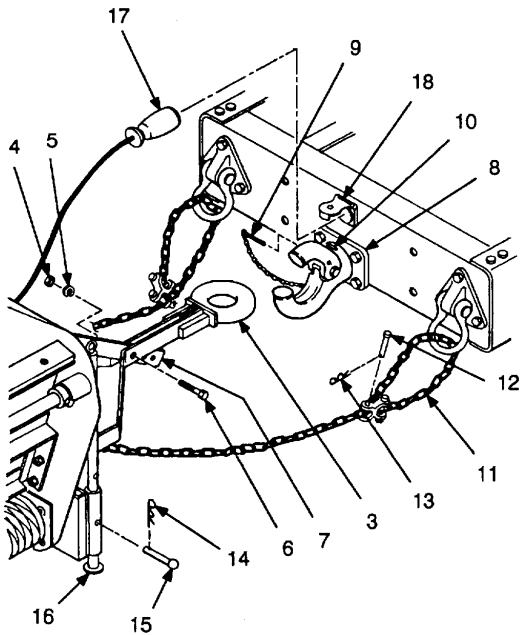

WARNING

Do not stand between spreader and towing vehicle when towing vehicle is in motion. Ensure that towing vehicle has come to a complete stop before coupling spreader. Failure to follow this warning could result in severe injury or death.

- (2) Back towing vehicle to spreader drawbar (3).

- (3) If necessary, have unit maintenance remove nut (4), lockwasher (5), and screw (6) from lift bar (7) and adjust height of drawbar (3) to match pintle (8). When drawbar is in proper position, secure lift bar with screw, new lockwasher, and nut.
- (4) Remove safety pin (9) from pintle (8) and pull up on locking latch (10) to lift pintle upper jaw.
- (5) Place drawbar (3) over pintle hook. Push down and close pintle upper jaw. Check that locking latch (10) is locked by pulling up on pintle upper jaw. Insert safety pin (9).

CAUTION

Safety chains support drawbar and keep spreader from fully breaking away from towing vehicle if drawbar detaches from pintle. Ensure that there is enough slack to allow spreader to make full turns.

- (6) Cross two safety chains (11) under drawbar (3) and hook to towing vehicle. Secure chains using pin (12) and hair pin (13).
- (7) Remove lock pin (14) and pin (15) from each jack leg (16). Raise jack legs by pulling up on eyebolts. Secure each jack leg in raised position with pin and lock pin.
- (8) Connect intervehicular cable connector plug (17) to towing vehicle's intervehicular connector (18).
- (9) Check operation of taillights before towing spreader.

2-8. OPERATING INSTRUCTIONS ON DECALS AND INSTRUCTION PLATES.

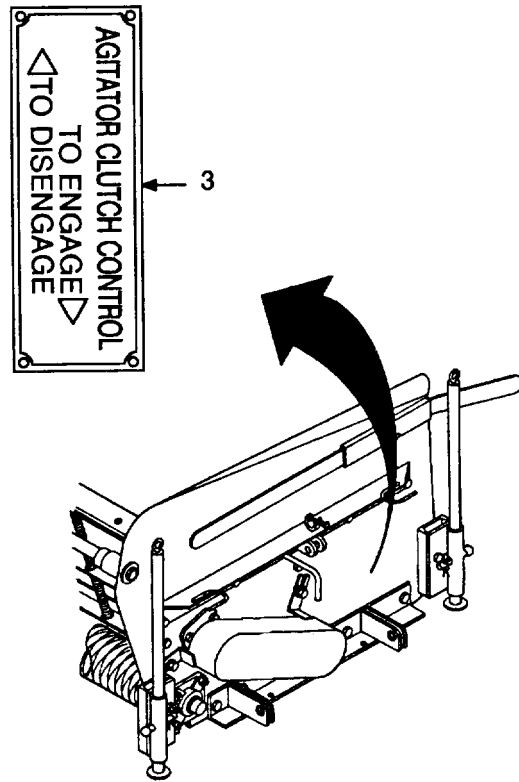
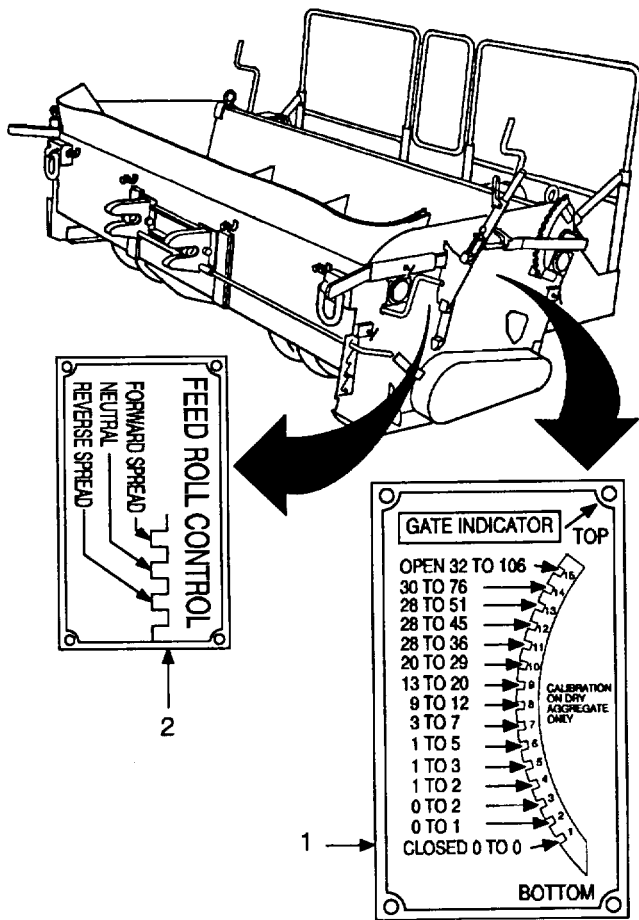

c. Agitator Clutch Control Plate (3). Provides instructions for engaging and disengaging agitator.

a. Gate Indicator Plate (1) Shows approximate flow rates (lb per sq yd) for each of 15 gate opening positions.

b. Feed Roll Control Plate (2). Shows operating and neutral positions of feed roll clutch control lever.

Section IV. OPERATION UNDER UNUSUAL CONDITIONS**2-9. OPERATION IN EXTREME COLD.**

Refer to Chapter 3, Section I for proper lubricants to use in extreme cold.

Ensure that tires are properly inflated (para 1-9). Under inflated tires may freeze to the ground or have flat spots. When parking short term, park in a sheltered area out of the wind.

When parking long term, place a footing of planks or brush under the tires and jack legs.

Remove any snow or ice from the spreader before and after operation.

If available, use a canvas cover to shield the spreader. Keep cover ends off the ground to keep them from freezing to the ground.

Do not operate the spreader if the aggregate is frozen.

2-10. OPERATION IN EXTREME HEAT AND HIGH HUMIDITY.

Refer to Chapter 3, Section I for proper lubricants to use in extreme heat.

Clean and lubricate more frequently when operating in extreme heat and high humidity. Coat exposed parts of polished steel or other ferrous metals with a light coat of oil or grease.

Do not park the spreader in sunlight for long periods of time. Heat and sunlight shorten tire life. If available, use canvas covers to shield the spreader.

2-11. OPERATION IN SNOW AND MUD.

Do not use the spreader in snow or mud.

2-12. OPERATION IN SANDY OR DUSTY AREAS.

Sand and dust destroy the protective qualities of lubricants. Clean and lubricate more frequently when operating in sandy or dusty areas. Coat exposed parts of polished steel or other ferrous metals with a light coat of oil or grease.

2-13. OPERATION IN SALTWATER AREAS.

Saltwater can rapidly cause corrosion and deterioration of exposed metal. Clean and lubricate frequently when operating in saltwater areas. Coat exposed parts of polished steel or other ferrous metals with a light coat of oil or grease.

2-14. FORDING.

Do not ford with spreader in its operational configuration. Spreader must be mounted on transport truck before fording.

Refer to towing vehicle's operator's manual for fording instructions. Maximum fording depth for the spreader is 22 in. (approximately the bottom of the feed roll).

Have unit maintenance repack wheel bearings after fording.

**CHAPTER 3
OPERATOR MAINTENANCE**

Section I. LUBRICATION INSTRUCTIONS

	Page		Page
3-1 General	3-1	3-3 Lubrication Instructions Under Unusual Conditions.....	3-2
3-2 Specific Lubrication Instructions	3-1		

Section II. OPERATOR TROUBLESHOOTING PROCEDURES

	Page		Page
3-4 General	3-6	3-6 Symptom Index.....	3-6
3-5 Explanation of Columns.....	3-6		

Section I. LUBRICATION INSTRUCTIONS

3-1. GENERAL.

NOTE

These instructions are MANDATORY

The spreader must receive lubrication with approved lubricants at recommended intervals in order to be mission-ready at all times.

The KEY lists lubricants to be used in all temperature ranges and shows the intervals.

The lubrication chart shows lubrication points, names items to be lubricated, the required lubricant, and recommended intervals for lubrication. Any special lubricating instructions required for specific components are contained in the NOTE S section of the chart.

Recommended intervals are based on normal conditions of operation, temperature, and humidity. When operating under extreme conditions, lubricants should always be changed more frequently. When in doubt, notify your supervisor.

3-2. SPECIFIC LUBRICATION INSTRUCTIONS.

Keep all lubricants in a closed container and store in a clean, dry place away from extreme heat. Keep container covers clean and do not allow dust, dirt, or

other foreign material to mix with lubricants. Keep all lubrication equipment clean and ready for use.

Maintain a record of lubrication performed and report any problems noted during lubrication. Refer to DA Pam 738-750 for applicable forms and procedures.

WARNING

Dry cleaning solvent P-D-680 is toxic and flammable. Wear protective goggles, face mask, and gloves and use in a well ventilated area. Avoid contact with skin, eyes, and clothes and do not breath vapors. Do not use near open flame or excessive heat. The flash point for Type I solvent is 100 degrees F (38 degrees C). The flash point for Type II solvent is 140 degrees F (60 degrees C). If you become dizzy while using cleaning solvent, get fresh air immediately and get medical aid. If contact with eyes is made, wash your eyes with water and get medical aid immediately.

Use dry cleaning solvent (Item 11, Appendix E) to clean grease fittings, lubrication points, and surrounding areas before lubricating.

When lubricating at a grease fitting, apply enough grease to purge old grease from the lubricated area. After lubrication, wipe off excess oil or grease to prevent accumulation of foreign matter.

Keep all external parts of equipment not requiring lubrication free of lubricants.

3-3. LUBRICATION INSTRUCTIONS UNDER UNUSUAL CONDITIONS.

Lubricate more frequently to compensate for abnormal or extreme conditions such as high or low temperatures, prolonged operation, continued operation in sand or dust, immersion in water, or exposure to moisture. Any one of these conditions may cause contamination and quickly destroy protective qualities of lubricants. Intervals may be extended during inactive periods commensurate with adequate preservation.

For lubrication instructions during continued operation below 0°F (-18°C), refer to FM 9-207.

Refer to TM 9-238 for lubrication instructions before and after fording.

After operation in sandy or dusty conditions, clean and inspect all lubrication points for fouled lubricants. Change lubricants as required.

LUBRICATION INSTRUCTIONS**SPREADER, AGGREGATE: TOWED; 8 FT SPREAD
FF-8 (NSN 3895-01-329-5096)**

Hard time intervals and related man-hour times are based on normal operation. The man-hour time specified is the time you need to do all services prescribed for a particular interval. Decrease the intervals if your lubricants are contaminated, or if you are operating equipment under adverse conditions, including longer-than-usual operating hours. The intervals may be extended during periods of low activity. If extended, adequate preservation precautions must be taken.

Dotted leader lines indicate lubrication is required on both sides of the equipment.

WARNING

Dry cleaning solvent P-D-680 is toxic and flammable. Wear protective goggles, face mask, and gloves and use in a well ventilated area. Avoid contact with skin, eyes, and clothes and do not breath vapors. Do not use near open flame or excessive heat.

The flash point for Type I solvent is 100 degrees F (38 degrees C). The flash point for Type II solvent is 140 degrees F (60 degrees C). If you become dizzy while using cleaning solvent, get fresh air immediately and get medical aid. If contact with eyes is made, wash your eyes with water and get medical aid immediately.

Clean all fittings and area around lubrication points with dry cleaning solvent (Item 11, Appendix E) or equivalent before lubricating equipment. After lubrication, wipe off excess oil or grease to prevent accumulation of foreign matter.

The lowest level of maintenance authorized to lubricate a point is indicated in parentheses by use of the following: (C) Operator/Crew; or (O) Organizational Maintenance.

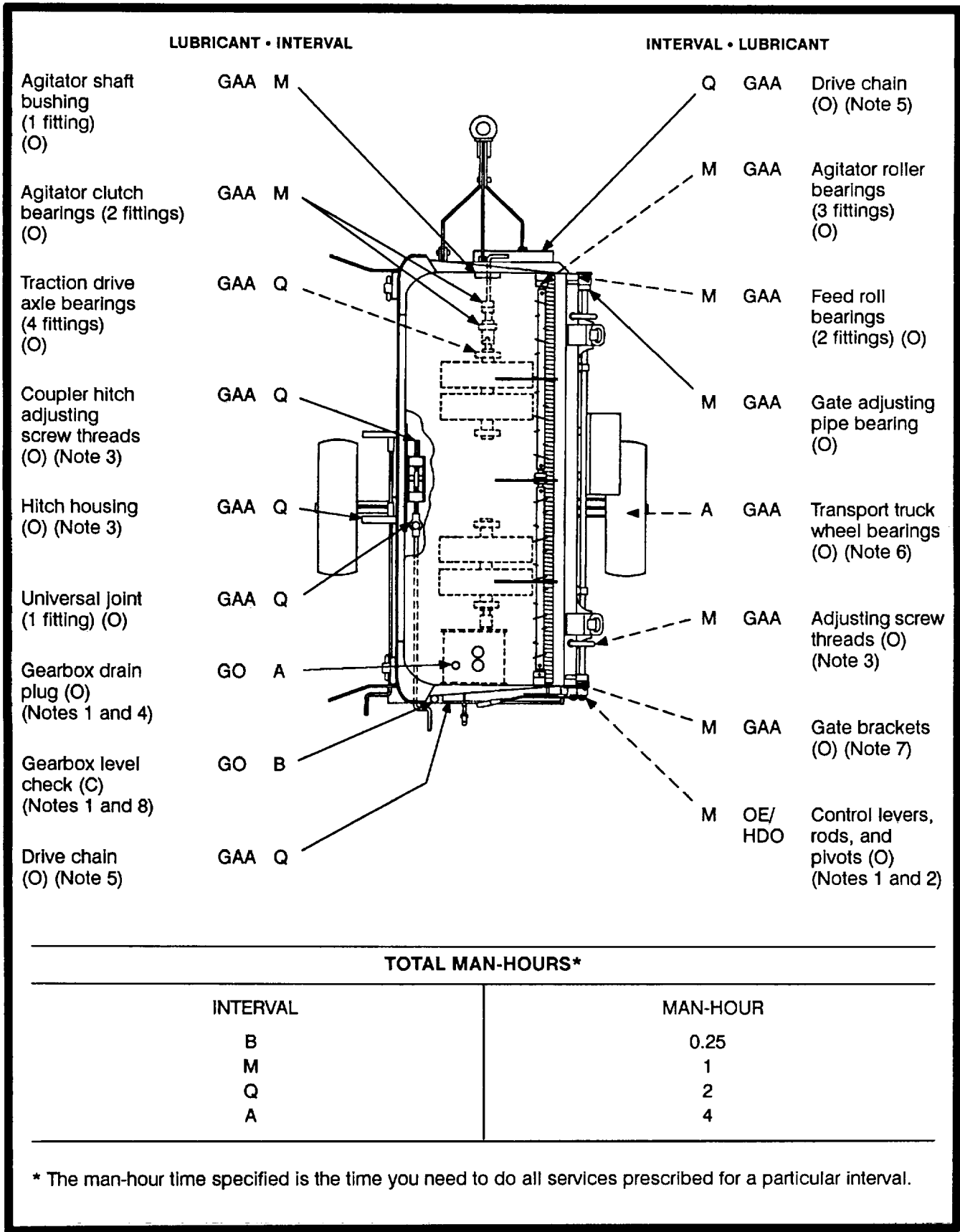

LUBRICANT • INTERVAL

INTERVAL • LUBRICANT

- Agitator shaft bushing (1 fitting) (O)
- Agitator clutch bearings (2 fittings) (O)
- Traction drive axle bearings (4 fittings) (O)
- Coupler hitch adjusting screw threads (O) (Note 3)
- Hitch housing (O) (Note 3)
- Universal joint (1 fitting) (O)
- Gearbox drain plug (O) (Notes 1 and 4)
- Gearbox level check (C) (Notes 1 and 8)
- Drive chain (O) (Note 5)

- GAA M
- GAA M
- GAA Q
- GAA Q
- GAA Q
- GAA Q
- GO A
- GO B
- GAA Q

- Q GAA Drive chain (O) (Note 5)
- M GAA Agitator roller bearings (3 fittings) (O)
- M GAA Feed roll bearings (2 fittings) (O)
- M GAA Gate adjusting pipe bearing (O)
- A GAA Transport truck wheel bearings (O) (Note 6)
- M GAA Adjusting screw threads (O) (Note 3)
- M GAA Gate brackets (O) (Note 7)
- M OE/HDO Control levers, rods, and pivots (O) (Notes 1 and 2)

TOTAL MAN-HOURS*

INTERVAL	MAN-HOUR
B	0.25
M	1
Q	2
A	4

* The man-hour time specified is the time you need to do all services prescribed for a particular interval.

- KEY -

LUBRICANTS	EXPECTED TEMPERATURES			INTERVALS
	ABOVE +32°F (ABOVE 0°C)	+32°F to -16°F (0°C to -26°C)	0°F to -65°F (-18°C to -54°C)	
GAA (MIL-G-10924) Grease, Automotive and Artillery	GAA All Temperatures			For arctic operation, refer to FM 9-207 B - Before Operation M - Monthly Q - Quarterly A - Annually
GO (MIL-L-2105) Lubricating Oil, Gear	GO-80/90		GO-75	
OE/HDO (MIL-L-2104) Lubricating Oil, Internal Combustion Engine, Tactical Service	OE/HDO-10		-	
OEA (MIL-L-46167) Lubricating Oil, Internal Combustion Engine, Arctic	-	-	OEA	

NOTES:

- FOR OPERATION OF EQUIPMENT IN PROTRACTED COLD TEMPERATURES BELOW -15°F (-26°C).** Remove lubricants prescribed in the key for temperatures above -15°F (-26°C). Lubricate with lubricants specified in the key for temperatures below -15°F (-26°C). If OEA lubricant is required to meet the temperature changes prescribed in the key, OEA lubricant is to be used in place of OE/HDO-10 lubricant for all temperature ranges where OE/HDO-10 lubricant is specified in the key.
- OIL CAN POINTS.** Lubricate all control lever pivots, exposed threads, and feed gate pivots with OE/HDO-10 monthly.
- CLEAN AND COAT.** Clean with dry cleaning solvent and allow to dry. Coat with prescribed lubricant.
- GEARBOX DRAIN PLUG.** Drain gearbox then add 4 qt gear oil annualpara 4-37 37).

- DRIVE CHAINS.** Remove cover from drive chain para 4-38 or 4-39 19). Clean chain with dry cleaning solvent and allow to dry. Coat chain with GAA and install cover.
- WHEEL BEARINGS.** Remove, clean, dry, and pack (refer to TM 9-214) with GAA annually (para 4-41).
- GATE BRACKETS.** Fully raise gate para 2-1 1). Clean brackets with dry cleaning solvent and allow to dry. Coat surface of brackets with GAA. Raise and lower gate several times to evenly distribute grease.
- GEARBOX LEVEL CHECK.** Before operation, check oil level. With spreader level, remove fill plug. Oil should be visible in pipe below elbow. Add GO as necessary, then install fill plug.

Section II. OPERATOR TROUBLESHOOTING

3-4. GENERAL.

Table 3-1 lists the common malfunctions that you may find during the operation or maintenance of the spreader or its components. You should perform the test/inspections and corrective actions in the order listed.

This section cannot list all malfunctions that may occur, nor all tests or Inspections and corrective actions. If a malfunction is not listed, or is not corrected by the listed corrective actions, notify your supervisor.

3-5. EXPLANATION OF COLUMNS.

a. *Malfunction.* A visual or operational indication that something is wrong with the spreader.

b. *Test or Inspection.* A procedure to isolate the problem in a component or system.

c. *Corrective Action.* A procedure to correct the problem.

3-6. SYMPTOM INDEX.

**Troubleshooting
Procedure Page**

ELECTRICAL SYSTEM

All lights do not light.....3-6
 Some (but not all) lights do not light.....3-6
 Dim or flickering lights.....3-6

PINTLES AND TOWING ATTACHMENTS

Spreader will not remain coupled.....3-7

**CONCRETE AND ASPHALT EQUIPMENT
COMPONENTS**

Spreader does not spread3-7

Table 3-1. OPERATOR TROUBLESHOOTING

**MALFUNCTION
TEST OR INSPECTION
CORRECTIVE ACTION**

ELECTRICAL SYSTEM

1. ALL LIGHTS DO NOT LIGHT.

Step 1. Check light panel switch on towing vehicle.

Set light panel switch to correct position (refer to towing vehicle's operator manual).

Step 2. Ensure that wiring harness is properly connected.

Reconnect wiring harness (para 2-7).

Step 3. Check wiring harness for damaged or corroded contacts and terminals.

Notify unit maintenance.

2. SOME (BUT NOT ALL) LIGHTS DO NOT LIGHT.

Step 1. Ensure that wiring harness is properly connected.

Reconnect wiring harness (para 2-7).

Step 2. Check for broken wires or damaged lights.

Notify unit maintenance.

3. DIM OR FLICKERING LIGHTS.

Step 1. Ensure that wiring harness is properly connected.

Reconnect wiring harness (para 2-7).

Step 2. Check intervehicular cable connector plug for damaged or corroded contacts.

Notify unit maintenance.

PINTLES AND TOWING ATTACHMENTS

4. SPREADER WILL NOT REMAIN COUPLED.

Step 1. Check for aggregate or other material blocking coupler hitch.

Remove any material preventing coupler hitch from closing.

Step 2. Check for broken or rounded coupler hitch dogs inside coupler hitch housing.

If dogs are broken or rounded, notify unit maintenance.

Step 3. Check that coupler hitch fully opens and closes when latch lever is turned (para 2-1).

If coupler hitch does not fully open and close, notify unit maintenance.

CONCRETE AND ASPHALT EQUIPMENT COMPONENTS

5. SPREADER DOES NOT SPREAD.

Step 1. Ensure that gate is open.

Open gate using gate adjusting lever (para 2-1). If gate does not open, notify unit maintenance.

Step 2. Ensure that agitator clutch control lever is in engaged position (pulled out) (para 2-1).

Pull out agitator clutch control lever.

Step 3. Check that agitator rotates while spreader is being towed.

If agitator does not rotate, notify unit maintenance.

Step 4. Ensure that feed roll control lever is set to proper position (para 2-1). If feed roll control lever is set to NEUTRAL, spreader will not spread. If feed roll control lever is set to FORWARD SPREAD and dump truck backs up, clutch will automatically disengage. If feed roll control lever is set to REVERSE SPREAD and dump truck moves forward, clutch will automatically disengage.

Set feed roll control lever to correct position. If feed roll control lever is set correctly, notify unit maintenance.

Step 5. Check that feed roll rotates while spreader is being towed. Ensure that feed roll control lever is set for direction of travel.

If feed roll does not rotate, notify unit maintenance.

**CHAPTER 4
UNIT MAINTENANCE**

Section I. REPAIR PARTS; SPECIAL TOOLS; TEST, MEASUREMENT, AND DIAGNOSTIC EQUIPMENT (TMDE); AND SUPPORT EQUIPMENT

	Page		Page
4-1 Common Tools and Equipment	4-2	4-3 Repair Parts	4-2
4-2 Special Tools, TMDE, and Support Equipment.....	4-2		

Section II. UNIT PREVENTIVE MAINTENANCE CHECKS AND SERVICES (PMCS)

	Page		Page
4-4 PMCS Procedures	4-2	4-6 Leakage Definitions	4-2
4-5 Explanation of Columns	4-2		

Section III. UNIT TROUBLESHOOTING PROCEDURES

	Page		Page
4-7 General.....	4-4	4-9 Symptom Index.....	4-4
4-8 Explanation of Columns	4-4		

Section IV. PREPARATION FOR OPERATION

	Page		Page
4-10 Introduction.....	4-9	4-13 Installing and Removing Truck Hitch	4-20
4-11 Removing and Installing Taillights.....	4-9	4-14 Installing and Removing Operator's Platform.....	4-24
4-12 Removing and Installing Transport Truck and Tongue	4-11	4-15 Coupling and Uncoupling Spreader.....	4-29

Section V. UNIT MAINTENANCE PROCEDURES

	Page		Page
4-16 Taillight Repair	4-31	4-30 Clutch Shift Arm Repair	4-48
4-17 Wiring Harness Repair.....	4-32	4-31 Gate Adjusting Lever and Rack Replacement.....	4-50
4-18 Transport Truck Axle Replacement	4-34	4-32 Gate Adjustment Screw Replacement.....	4-51
4-19 Transport Truck Wheel Replacement	4-35	4-33 Gate Adjusting Shaft and Bearings Replacement.....	4-52
4-20 Transport Truck Wheel Hub Repair	4-36	4-34 Belting Replacement.....	4-53
4-21 Tires and Tubes Repair.....	4-37	4-35 Balancing Handle Replacement.....	4-55
4-22 Operator's Platform Repair	4-38	4-36 Gate and Brackets Replacement.....	4-56
4-23 Transport Tongue and Mounting Components Replacement.....	4-41	4-37 Gearbox Replacement.....	4-57
4-24 Truck Hitch Replacement.....	4-43	4-38 Agitator Drive Chain Replacement.....	4-62
4-25 Leveling Leg Repair	4-44	4-39 Feed Roll Drive Chain and Sprocket Replacement.....	4-63
4-26 Reflector Replacement.....	4-45	4-40 Balance Roller Repair.....	4-64
4-27 Toolbox Replacement	4-46	4-41 Traction Wheel Assembly Repair	4-66
4-28 Data Plate Replacement	4-46		
4-29 Feed Roll Control Lever Replacement.....	4-47		

Section VI. PREPARATION FOR STORAGE OR SHIPMENT

	Page		Page
4-42 Administrative Storage	4-71	4-43 Preparation for Shipment.....	4-73

Section I. REPAIR PARTS; SPECIAL TOOLS; TEST, MEASUREMENT, AND DIAGNOSTIC EQUIPMENT (TMDE); AND SUPPORT EQUIPMENT

4-1. COMMON TOOLS AND EQUIPMENT.

For authorized common tools and equipment, refer to the Modified Table of Organization and Equipment (MTOE) applicable to your unit.

4-2. SPECIAL TOOLS, TMDE, AND SUPPORT EQUIPMENT.

No special tools, TMDE, and support equipment are

required to maintain the aggregate spreader.

4-3. REPAIR PARTS.

Repair parts are listed and illustrated in Appendix F of this manual.

Section II. UNIT PREVENTIVE MAINTENANCE CHECKS AND SERVICES (PMCS)

4-4. PMCS PROCEDURES.

Your PMCS table lists the inspections and care required to keep your equipment in good operating condition.

If your equipment does not perform as required, refer to troubleshooting procedures in Section III of this chapter. Report any malfunctions or failures on DA Form 2404 or refer to DA Pam 738-750.

4-5. EXPLANATION OF COLUMNS.

a. *Item No.* This column lists a logical order for performing PMCS. Use the number in this column as the "TM Item No." on DA Form 2404, Equipment Inspection and Maintenance Worksheet, when recording the results of PMCS.

b. *Interval.* The dot in this column tells you when to do a certain check or service.

c. *Item to be Inspected.* This column lists the specific item being inspected.

d. *Procedures.* This column tells you how to do the required checks and services. Carefully follow these instructions.

4-6. LEAKAGE DEFINITIONS.

It is necessary for you to know how fluid leakage affects the status of your equipment. The following are definitions of the types/classes of leakage you need to know to be able to determine the status of your spreader. Leakage Definitions for Unit PMCS

- Class I Seepage of fluid (as indicated by wetness or discoloration) not great enough to form drops.
- Class II Leakage of fluid great enough to form drops, but not great enough to cause drops to drip from the item being inspected.
- Class III Leakage of fluid great enough to form drops that fall from the item being inspected.

CAUTION

Equipment operation is allowed with minor leakage (Class I or II). Of course, you must consider the fluid capacity in the item/system being checked/inspected. When in doubt, notify your supervisor.

Class III leaks must be corrected before releasing the spreader for operation.

Table 4-1. UNIT PREVENTIVE MAINTENANCE CHECKS AND SERVICES (PMCS)

M - Monthly

Q-Quarterly

A-Annually

ITEM NO.	INTERVAL		ITEM TO BE
	M	Q	
NOTE Perform operator PMCS prior to or in conjunction with unit PMCS.			
1	•		Transport truck and tongue Inspect for cracks, breaks, bends, and broken welds. Repair or replace as required (para 4-18 or 4-23).
2	•		Transport wheels Inspect for cracks, breaks, or bends. Replace any defective parts (para 4-19 or 4-20).
3		•	Transport wheel bearings Remove bearings (para 4-20). Clean, inspect, and pack in accordance with TM 9-214.
4	•		Coupler hitch Inspect for cracks, breaks, or damaged hardware. Report deficiencies to direct support maintenance.
5	•		Control levers and linkages Check all levers and linkages for proper operation. Replace as required (para 4-29 through 4-32).
6	•		Hopper Inspect for cracks, breaks, or broken welds. Report deficiencies to direct support maintenance.
7	•		Agitator Inspect for cracks, broken vanes, or other damage. Report deficiencies to direct support maintenance.
8	•		Chains and sprockets Inspect for cracked or broken links. Replace defective chains (paras 4-39 and 4-38). Inspect sprockets for chipped or cracked teeth. If feed roll drive shaft sprocket is damaged, replace (para 4-39). If any other sprocket is damaged, notify direct support maintenance.
9	•		Feed roll bearings and shaft Ensure that bearings turn easily and shaft is not bent. Report deficiencies to direct support maintenance.
10	•		Balance roller Ensure that balance roller turns easily and is not bent or broken. Replace or repair defective balance roller (para 4-40).
11	•		Traction wheels Inspect for cracks, breaks, or bends. Replace any defective parts (para 4-41).
12	•		Traction wheel bearings and axles Ensure that axles turn freely and are not bent or broken. Replace defective axles or bearings (para 4-41).

Section III. UNIT TROUBLESHOOTING PROCEDURES

4-7. GENERAL.

Table 4-2 lists the common malfunctions that you may find during the operation or maintenance of the spreader or its components. You should perform the test/inspections and corrective actions in the order listed.

This section cannot list all malfunctions that may occur, nor all tests or inspections and corrective actions. If a malfunction is not listed, or is not corrected by the listed corrective actions, notify your supervisor.

4-8. EXPLANATION OF COLUMNS.

- a. *Malfunction.* A visual or operational indication that something is wrong with the spreader.
- b. *Test or Inspection.* A procedure to isolate the problem in a component or system.
- c. *Corrective Action.* A procedure to correct the problem.

4-9. SYMPTOM INDEX.

**Troubleshooting
Procedure Page**

ELECTRICAL SYSTEM

- All lights do not light.....4-4
- One or more (but not all) lights fail to light.....4-5
- Dim or flickering lights.....4-6

PINTLES AND TOWING ATTACHMENTS

- Coupler hitch will not lock onto truck hitch.....4-7
- Coupler hitch will not adjust.....4-7
- Coupler hitch will not latch or release.....4-7

HOPPERS, GATES, AND CHUTES

- Gate will not open, close, or adjust.....4-7

VANE OR SCREW FEEDERS OR CONVEYORS

- Agitator will not rotate.....4-7

FEEDING OR CONVEYOR SHAFT

- Feed roll will not rotate..... 4-8

Table 4-2. UNIT TROUBLESHOOTING

MALFUNCTION	TEST OR INSPECTION	CORRECTIVE ACTION
--------------------	---------------------------	--------------------------

1. ALL LIGHTS DO NOT LIGHT.

Step 1. Check wiring harness for loose connections and broken wiring.

Tighten loose connections.
Replace or repair wiring harness (para 4-17).

Step 2. Check wiring harness for bare spot causing short circuit.

Replace or repair wiring harness (para 4-17).

Step 3. Verify power coming from towing vehicle as follows:

- a. Set multimeter to 50 vdc range.
- b. Connect multimeter red lead to towing vehicle connector pin B. Connect black lead to ground.
- c. Apply power as appropriate (turn on light switch, apply brakes).

If multimeter does not indicate approximately 24 vdc, troubleshoot towing vehicle (refer to appropriate technical manual for towing vehicle).

If multimeter indicates approximately 24 vdc, check towing vehicle connector pins D, E, and J. If multimeter indicates approximately 24 vdc for each pin, continue with this troubleshooting procedure.

Step 4. Check ground lead for continuity as follows:

- a. Disconnect wiring harness from towing vehicle.
- b. Disconnect ground lead (black) from back of each light assembly (para 4-16).
- c. Connect multimeter red lead to harness connector pin D. Connect black lead to end of ground lead.

If continuity is not present, replace wiring harness (para 4-17). If continuity is present, reconnect ground lead.

Step 5. Check all electrical leads for continuity as follows:

- a. Remove lens and lamps from each light assembly (para 4-16).

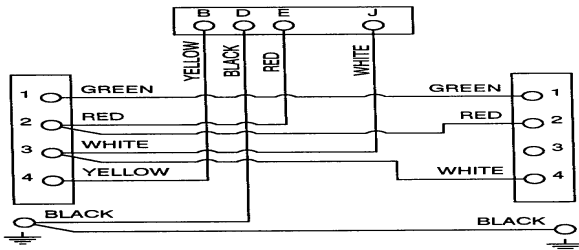

NOTE

The only wires used are the ones illustrated. All other wires are cut.

- b. Refer to wiring diagram. Check each lead for continuity.

If continuity is not present in any lead, replace wiring harness (para 4-17). If continuity is present in all leads, replace light assembly (para 4-16).

2. ONE OR MORE (BUT NOT ALL) LIGHTS FAIL TO LIGHT.

- Step 1. Replace inoperative lamp (para 4-16).
Check operation of lamp. If lamp does not operate, continue with this troubleshooting procedure.
- Step 2. Check wiring harness for loose connections and broken wires.
Tighten loose connections. Replace or repair wiring harness (para 4-17).
- Step 3. Disconnect wiring harness plug and check for loose, dirty, or corroded contacts.

WARNING

Dry cleaning solvent PD680 is toxic and flammable. Wear protective goggles, face mask, and gloves and use in a well ventilated area. Avoid contact with skin, eyes, and clothes and do not breath vapors. Do not use near open flame or excessive heat. The flash point for Type I solvent is 100 degrees F (38 degrees C). The flash point for Type II solvent is 140 degrees F (60 degrees C). If you become dizzy while using cleaning solvent, get fresh air immediately and get medical aid. If contact with eyes is made, wash your eyes with water and get medical aid immediately.

- Step 4. Verify power coming from towing vehicle as follows:
 - a. Set multimeter to 50 vdc range.
 - b. Refer to wiring diagram. Connect multimeter red lead to towing vehicle connector for inoperative lamp. Connect black lead to ground.
 - c. Apply power as appropriate (turn on light switch, apply brakes).

If multimeter does not indicate approximately 24 vdc, troubleshoot towing vehicle (refer to appropriate technical manual for towing vehicle). If multimeter indicates approximately 24 vdc, continue with this troubleshooting procedure.

Table 4-2. UNIT TROUBLESHOOTING (CONT)

MALFUNCTION	TEST OR INSPECTION	CORRECTIVE ACTION
-------------	--------------------	-------------------

- Step 5. Check voltage as follows for each inoperative lamp until problem is isolated:
- Connect wiring harness to towing vehicle.
 - Remove lens from each light assembly.

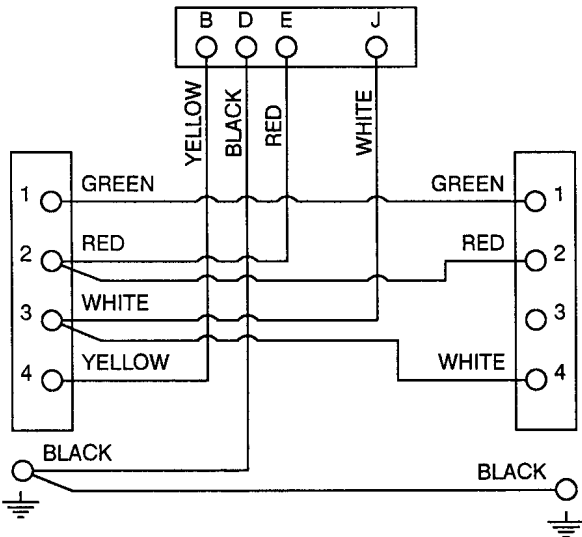

NOTE

The only wires used are the ones illustrated. All other wires are cut.

COLOR DESCRIPTION

- Green Backup
- Red Service taillight
- White Right hand service signal
- Yellow Left hand service signal
- Black Ground

- Refer to wiring diagram. Connect red multimeter lead to terminal for inoperative lamp. Connect black multimeter lead to ground.

- Apply power as appropriate (turn on light, apply brakes).
 - If no voltage is present, replace or repair wiring harness (para 4-17).
 - If voltage is present, proceed to Step e.
- Remove lamp from socket. Connect red multimeter lead to lamp socket and black lead to ground. Apply power as appropriate (turn on light, apply brakes).
 - If no voltage is present, replace light assembly (para 4-16).

3.

DIM OR FLICKERING LIGHTS.

- Step 1. Check wiring harness for loose connections and broken wires.

Tighten loose connections. Replace or repair wiring harness (para 4-17).

- Step 2. Check ground lead for continuity as follows:

- Disconnect wiring harness from towing vehicle.
- Remove lens from each light assembly.
- Connect multimeter red lead to harness connector pin D. Connect black lead to end of ground lead.

If continuity is not present, replace wiring harness (para 4-17). If continuity is present, reconnect ground lead.

- Step 3. Check electrical leads for continuity as follows:

- Remove lens from each light assembly.
- Refer to wiring diagram. Check each lead for continuity.

If continuity is not present in any lead, replace wiring harness (para 4-17). If continuity is present in all leads, replace light assembly (para 4-16).

PINTLES AND TOWING ATTACHMENTS

4. COUPLER HITCH WILL NOT LOCK ONTO TRUCK HITCH.

- Step 1. Check for aggregate or other material blocking coupler hitch.
Remove any material preventing coupler hitch from closing.
- Step 2. Check that coupler hitch opens and closes when latch lever is turned.
If coupler hitch does not open and close, notify direct support maintenance.
- Step 3. Ensure that coupler hitch height is set correctly.
Rotate hitch adjusting crank to adjust coupler hitch height. If hitch adjusting crank will not turn or coupler hitch height cannot be adjusted, notify direct support maintenance.

5. COUPLER HITCH WILL NOT ADJUST.

- Step 1. Check screw thread, universal joint, and housing for proper lubrication.
Lubricate In accordance with lubrication chart (Chapter 3, Section I).
- Step 2. Check adjustment screw for damaged threads. Ensure that adjustment screw is not bent or otherwise damaged.
If damaged, notify direct support maintenance.
- Step 3. Check pantograph links for deformation and damage.

Notify direct support maintenance.

6. COUPLER HITCH WILL NOT LATCH OR RELEASE.

Check coupler hitch housing for damage, rust or corrosion, or missing parts.

Notify direct support maintenance.

HOPPERS, GATES, AND CHUTES

7. GATE WILL NOT OPEN, CLOSE, OR ADJUST.

- Step 1. Check gate adjusting shaft bearings and adjusting screw threads for proper lubrication.
Lubricate in accordance with lubrication chart (Chapter 3, Section I).
- Step 2. Check gate adjusting lever for damage.
Replace gate adjusting lever (para 4-31).
- Step 3. Check gate adjustment screws for damage.
Replace gate adjustment screws (para 4-32).
- Step 4. Check gate adjusting shaft and bearings for damage, rust or corrosion, or missing parts.
Replace gate adjusting shaft and bearings (para 4-33).
- Step 5. Check gate and gate brackets for damage, rust or corrosion, or missing parts.
Replace gate and brackets (para 4-36).

VANE OR SCREW FEEDERS OR CONVEYORS

8. AGITATOR WILL NOT ROTATE.

- Step 1. Check agitator drive chain for damage.
Replace agitator drive chain (para 4-38).
- Step 2. Check drive chain sprockets for damage.

Notify direct support maintenance.

- Step 3. Check agitator pipes, couplings, and bearings for damage, rust or corrosion, or missing parts.

Notify direct support maintenance.

- Step 4. Check agitator clutch, drive shaft, yoke, and collars for damage, rust or corrosion, or missing parts.

Notify direct support maintenance.

Table 4-2. UNIT TROUBLESHOOTING (CONT)

MALFUNCTION	TEST OR INSPECTION	CORRECTIVE ACTION
Step 5. Check traction drive wheels, bearings, and coupling for damage, rust or corrosion, or missing parts.	Replace traction drive	Replace feed roll control lever (para 4-29) or shift arm (para 4-30).
(para 4-41).		Replace feed roll drive chain (para 4-39).
<i>FEEDING OR CONVEYOR SHAFT</i>		
9. FEED ROLL WILL NOT ROTATE.		
Step 1. Check feed roll and bearings for damage, rust or corrosion, or missing parts.	Notify direct support	Step 3. Check feed roll drive chain for damage.
maintenance.		If sprocket on gearbox drive shaft is damaged, replace (para 439). If sprocket on feed roll is damaged, notify direct support maintenance.
Step 2. Check feed roll control lever and shift arm for damage, rust or corrosion, or missing parts. Ensure that feed roll control lever is connected to clutch shift arm and that clutch shift arm is connected to gearbox shaft.		Step 5. Check traction drive wheels, bearings, and coupling for damage, rust or corrosion, or missing parts.
		Replace traction drive
		(para 4-41).
		Step 6. Check gearbox and shafts for damage, rust or corrosion, or missing parts.
		Replace gearbox (para
		4-37).

Section IV. PREPARATION FOR OPERATION

4-10. INTRODUCTION.

This section contains Instructions for preparing the spreader for operation and preparing the spreader for transportation after operation. To prepare the spreader for operation, perform the following tasks in the order listed:

- a. Remove taillights (para 4-11).
- b. Remove transport truck and tongue (para 4-12).
- c. Install truck hitch on dump truck (para 4-13).
- d. Install operator's platform on spreader (para 4-14).
- e. Couple spreader to dump truck (para 4-15).

The spreader can be transported short distances, off road, while still coupled to the dump truck. See paragraph 2-7. To prepare the spreader for long distance,

4-11. REMOVING AND INSTALLING TAILLIGHTS.

This task covers:

a. Removal

b. Installation

highway transportation, perform the following tasks in the order listed:

- a. Uncouple spreader from dump truck (para 4-15).

- b. Remove truck hitch from dump truck (para 4-13).
- c. Remove operator's platform from spreader (para 4-14).
- d. Install transport truck and tongue on spreader (para 4-12).
- e. Install taillights on spreader (para 4-11).

Always refer to the applicable operator's TM listed in paragraph 1-1 when instructed to operate the dump truck.

INITIAL SETUP:

Tools:

Tool Kit, General Mechanic's Automotive

Materials/Parts:

Tiedown straps (Item 12, Appendix E)

Equipment Conditions:

Spreader parked on level ground and uncoupled from prime mover.

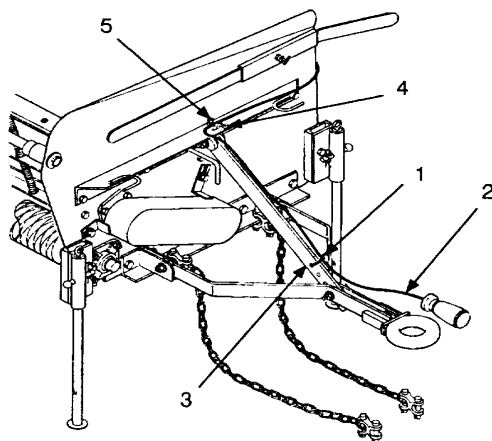

a. Removal.

- (1) Cut and remove tiedown straps (1) securing harness (2) to lift bar (3).
- (2) Loosen screw (4) in C-clamp (5) and remove harness (2) from C-clamp.

4-11. REMOVING AND INSTALLING TAILLIGHTS (CONT).

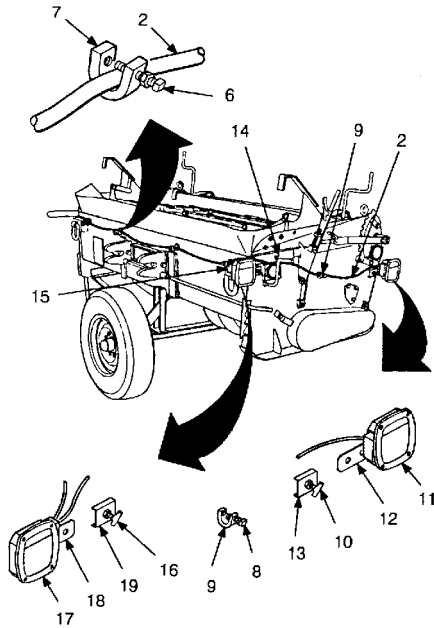

- (3) Along front of spreader, loosen screws (6) in four C-clamps (7) and remove harness (2) from C-clamps.
- (4) On left side of spreader, loosen screw (8) in C-clamp (9) and remove harness (2) from C-clamp.
- (5) Loosen thumbscrew (10) and remove taillight (11) and bracket (12) from holder (13).
- (6) Loosen thumbscrew (14) and pull out balancing handle (15).
- (7) Loosen thumbscrew (16) and remove taillight (17). Remove two taillights and harness from spreader. Retain for storage on transport truck.
- (8) Push In balancing handle (15) and tighten thumbscrew (14).

(9) Remove transport truck and tongue from spreader (para 4-12).

b. *Installation.*

- (1) Loosen thumbscrew (14) and slide balancing handle (15) out several inches to keep it from interfering with left taillight (17). Tighten thumbscrew.
- (2) Slide right taillight bracket (12) into holder (13) and tighten thumbscrew (10).
- (3) Route harness (2) through C-clamp (9) and tighten screw (8) in C-clamp.
- (4) Slide left taillight bracket (18) into holder (19) and tighten thumbscrew (16).
- (5) Along front of spreader, route harness (2) through four C-clamps (7) and tighten screws (6) in C-clamps.

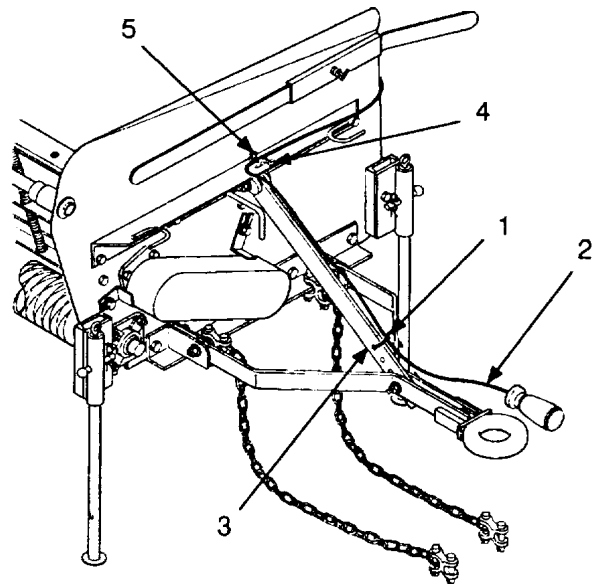

(6) On right side of spreader, route harness (2) through C-clamp (5) and tighten screw (4) in C-clamp.

(7) Secure harness (2) to lift bar (3) using tiedown strap (1).

4-12. REMOVING AND INSTALLING TRANSPORT TRUCK AND TONGUE.

This task covers:

a. Removal

b. Installation

INITIAL SETUP:

Tools:

Tool Kit, General Mechanic's Automotive
Lifting device with 2400 lb capacity
Lifting slings or chains
Torque wrench

Materials/Parts

Tiedown straps (Item 12, Appendix E)
Nine lockwashers

Personnel Required: Three

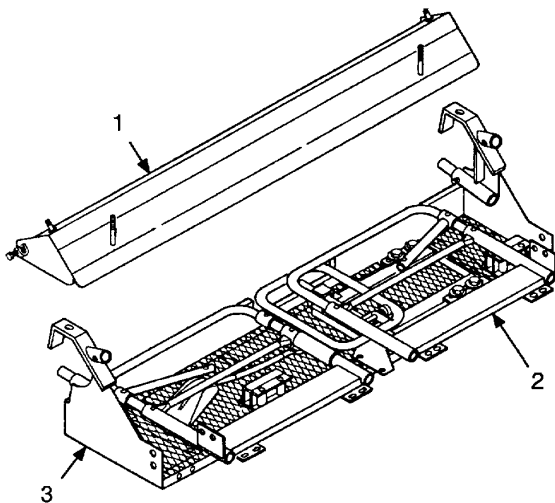

a. Removal.

- (1) Cut and remove tiedown straps securing chute (1) and left-hand rail (2) to operator's platform (3). Remove chute and left-hand rail from operator's platform.

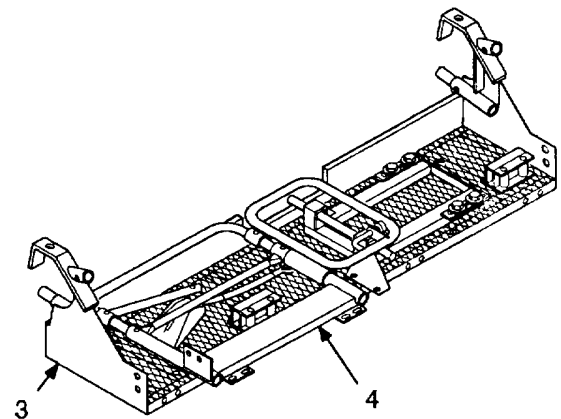

- (2) Cut and remove tiedown straps securing right-hand rail (4) to operator's platform (3). Remove right-hand rail from operator's platform.

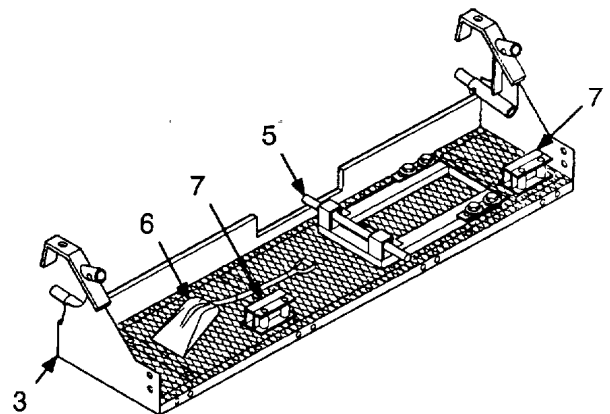

- (3) Cut and remove tiedown straps securing truck hitch (5), shovel (6), and two spacers (7) to operator's platform (3). Remove truck hitch, shovel, and two spacers from operator's platform.

4-12. REMOVING AND INSTALLING TRANSPORT TRUCK AND TONGUE (CONT).

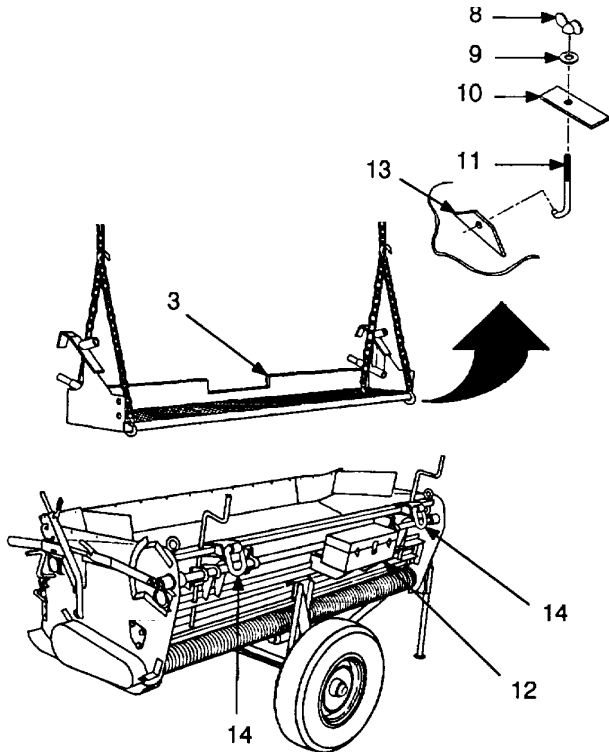

WARNING

Keep clear of equipment when it is being raised and lowered. Do not allow heavy components to swing while suspended by a lifting device. Exercise extreme caution when working near a cable under tension. Failure to follow this warning may result in severe injury or death to personnel.

NOTE

Two people should balance operator's platform while the third person operates lifting device.

- (4) Remove wingnut (8), flatwasher (9), and plate (10) from each of four J-bolts (11).
- (5) Store wingnuts (8), flatwashers (9), and plates (10) in spreader toolbox (12).
- (6) Secure lifting slings or chains to grating inside operator's platform (3).

- (7) Using a suitable lifting device, remove operator's platform (3) (125 lb) from hopper and set on ground.
- (8) Remove lifting slings or chains from operator's platform (3).
- (9) Unhook four J-bolts (11) from lugs (13) inside hopper and remove. Store in spreader toolbox (12).
- (10) Connect lifting slings or chains to four D-rings (14) on hopper.

WARNING

Keep clear of equipment when it is being raised and lowered. Do not allow heavy components to swing while suspended by a lifting device. Exercise extreme caution when working near a cable under tension. Failure to follow this warning may result in severe injury or death to personnel.

- (11) Using a suitable lifting device, lift spreader (2400 lb) enough to get weight off transport truck tires.

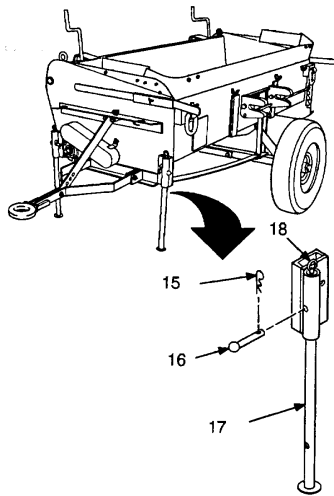

NOTE

If transport truck is being removed so that spreader can be operated, fully raise leveling legs. If transport truck is being removed to perform maintenance, secure leveling legs in center position.

- (12) Remove lock pin (15) and pin (16) from each leveling leg (17). Raise leveling legs by pulling up on eyebolts (18). Secure each leveling leg in raised position using pin and lockpin.

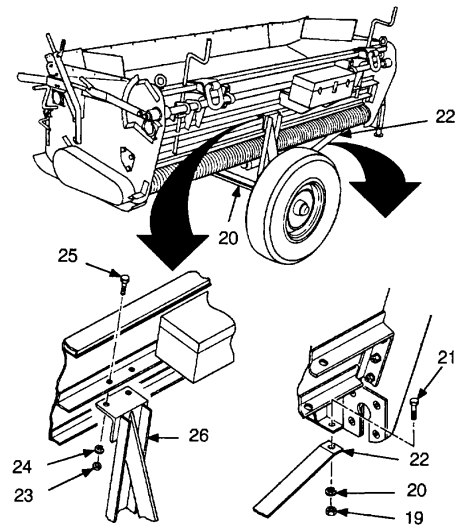

- (13) At rear of spreader, remove nut (19), lockwasher (20), and screw (21) securing bracket (22) to hopper. Loosen mounting hardware at other end of bracket. Discard lockwasher.
- (14) At rear of spreader, remove two nuts (23), lockwashers (24), and screws (25) from transport truck (26). Discard lockwashers.

4-12. REMOVING AND INSTALLING TRANSPORT TRUCK AND TONGUE (CONT).

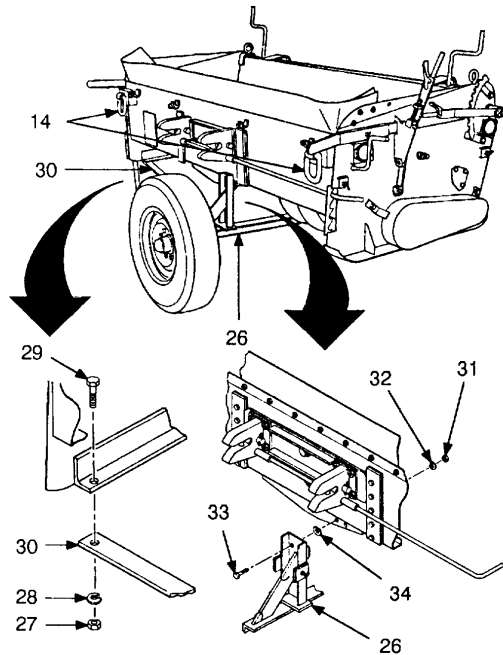

- (15) At front of spreader, remove nut (27), lockwasher (28), and screw (29) securing bracket (30) to hopper. Loosen mounting hardware at other end of bracket. Discard lockwasher.
- (16) At front of spreader, remove two nuts (31), lockwashers (32), screws (33), and spacers (34) (if equipped) from transport truck (26). Discard lockwashers.

WARNING

Keep clear of equipment when it is being raised and lowered. Do not allow heavy components to swing while suspended by a lifting device. Exercise extreme caution when working near a cable under tension. Failure to follow this warning may result in severe injury or death to personnel.

NOTE

Two people should balance spreader while the third person operates lifting device.

- (17) Lift spreader sufficiently to clear transport truck (26).
- (18) Roll transport truck (26) out from underneath spreader.
- (19) Lower spreader to ground and remove lifting slings or chains from D-rings (14).
- (20) Stow transport truck mounting hardware on transport truck (26).
- (21) Stow bracket attaching hardware on brackets (22 and 30).

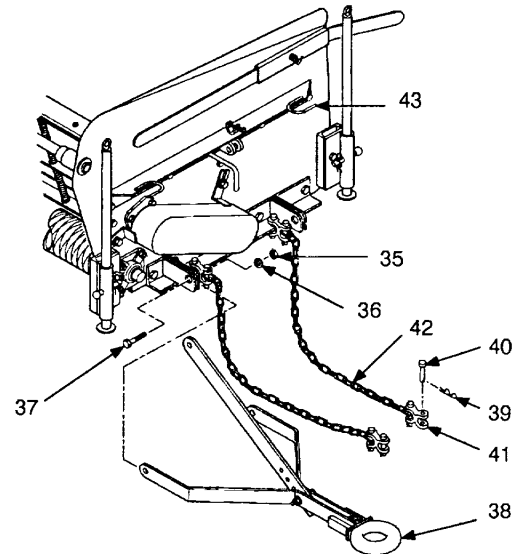

- (22) Remove three nuts (35), lockwashers (36), and screws (37). Remove transport tongue (38) from hopper. Discard lockwashers. Stow transport tongue mounting hardware on transport tongue.
- (23) Remove hair pin (39) and pin (40) from clevis (41). Wrap safety chain (42) around hooks (43), then secure in place with pin and lock pin.
- (24) Repeat step (22) for remaining safety chain.

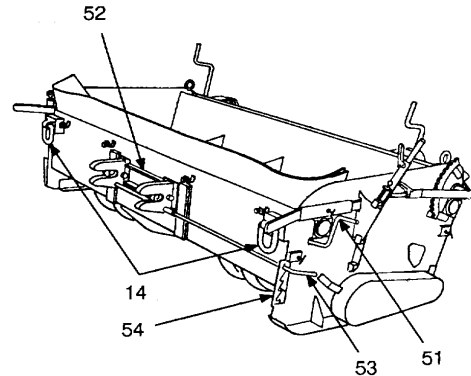
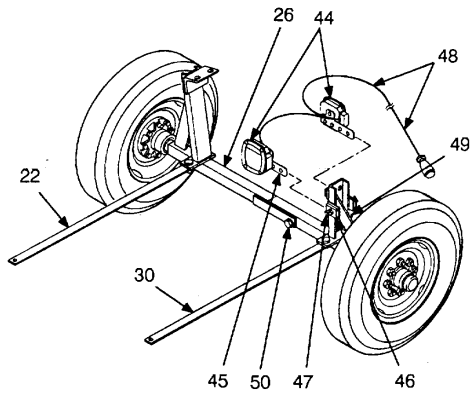

(25) Stow taillights (44) on transport truck (26) by sliding taillight brackets (45) into holders (46) and tightening thumbscrews (47). Wrap harness (48) around half-rings (49).

(26) Install truck hitch on dump truck (para 4-13).

b. *Installation.*

- (1) Unwrap harness (48) from two half-rings (49) on transport truck (26).
- (2) Loosen thumbscrews (47) and remove taillights (44) from holders (46).
- (3) Ensure that bolt (50) and nut are tight. Tighten to 120 lb-ft if necessary.
- (4) Remove mounting hardware stowed on brackets (22 and 30) and transport truck (26).

CAUTION

Do not force hitch adjusting crank beyond its limits of travel. Failure to follow this caution could cause universal joint to jam.

- (5) Using hitch adjusting crank (51), raise coupler hitch (52) to its highest position to prevent any interference with transport truck tires. While raising coupler hitch, keep an eye on latch lever (53). If latch lever starts to bind, release it from support (54) and place in a higher tooth in support.
- (6) Connect lifting slings or chains to four D-rings (14) on hopper.

WARNING

Keep clear of equipment when it is being raised and lowered. Do not allow heavy components to swing while suspended by a lifting device. Exercise extreme caution when working near a cable under tension. Failure to follow this warning may result in severe injury or death to personnel.

NOTE

Two people should balance spreader while the third person operates lifting device.

- (7) Using a suitable lifting device, lift spreader (2000 lb) sufficiently to clear transport truck axles. Spreader must be level.

4-12. REMOVING AND INSTALLING TRANSPORT TRUCK AND TONGUE (CONT).

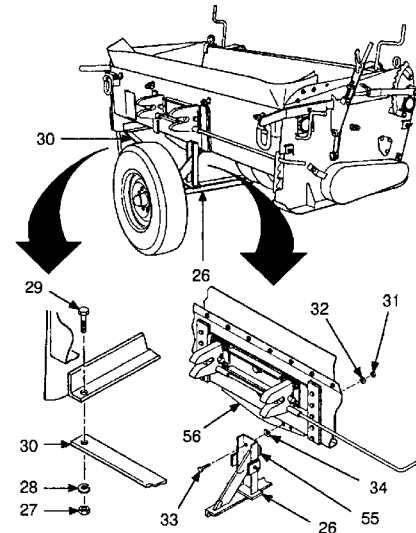
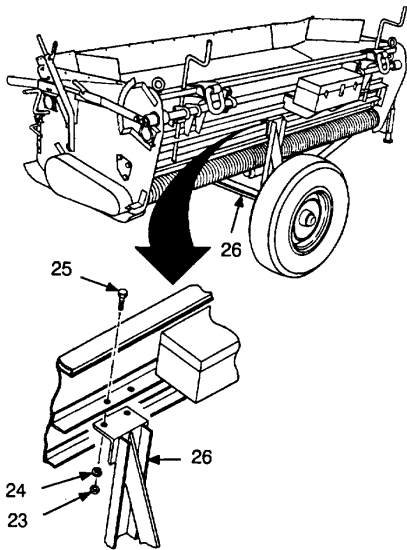

- (8) Roll transport truck (26) underneath spreader with higher side of transport truck to rear of spreader.
- (9) Lower spreader onto transport truck (26). Continue to support spreader with lifting device.

NOTE

- **Do not fully tighten any transport truck mounting hardware until instructed to do so.**
 - **Shorter mounting screws are used on rear of transport truck. Longer mounting screws are used at front of transport truck.**
- (10) At rear of spreader, Install two shorter screws (25), new lockwashers (24), and nuts (23) to secure rear of spreader to transport truck (26).

WARNING

Do not put hands in between spreader and transport truck while spreader is suspended. Failure to follow this warning could result in injury.

- (11) At front of spreader, install two longer screws (33), spacers (34) (if equipped), new lockwashers (32), and nuts (31) to secure front of spreader to transport truck (26). Tighten screws until welded spacer (55) is flush with bracket (56).
- (12) Secure bracket (30) to spreader using screw (29), new lockwasher (28), and nut (27).

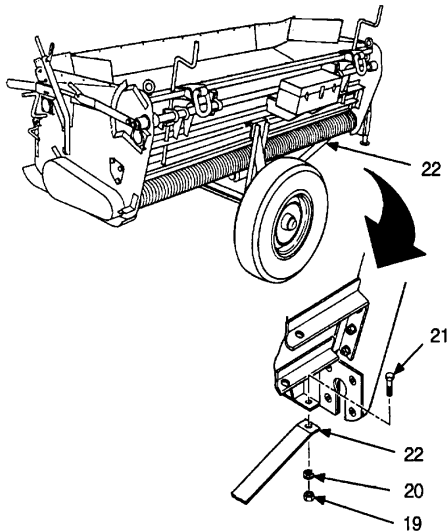

- (13) Secure remaining bracket (22) to spreader using screw (21), new lockwasher (20), and nut (19).
- (14) Fully tighten all transport truck mounting hardware. Tighten bracket mounting hardware to 60 lb-ft. Tighten all other transport truck mounting hardware to 120 lb-ft.

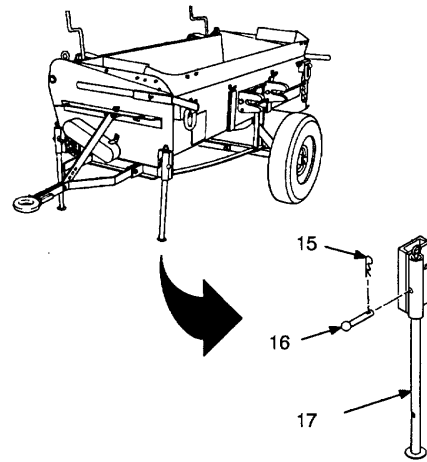

- (15) Remove lock pin (15) and pin (16) from each leveling leg (17). Lower leveling legs and secure in lowered position with pins and lock pins.

WARNING

Keep clear of equipment when it is being raised and lowered. Do not allow heavy components to swing while suspended by a lifting device. Exercise extreme caution when working near a cable under tension. Failure to follow this warning may result in severe injury or death to personnel.

- (16) Lower spreader and remove lifting slings or chains from hopper.

4-12. REMOVING AND INSTALLING TRANSPORT TRUCK AND TONGUE (CONT).

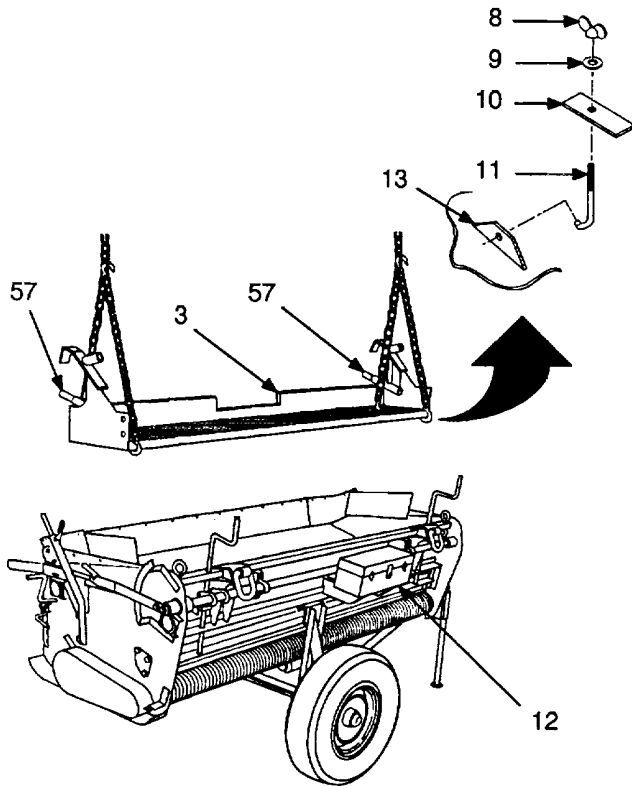

- (19) Remove four wingnuts (8), flatwashers (9), plates (10), and J-bolts (11) from spreader toolbox (12).
- (20) Loop J-bolts (11) through lugs (13) inside hopper. Install plate (10), flatwasher (9), and wingnut (8) on each J-bolt to secure operator's platform (3) to hopper.

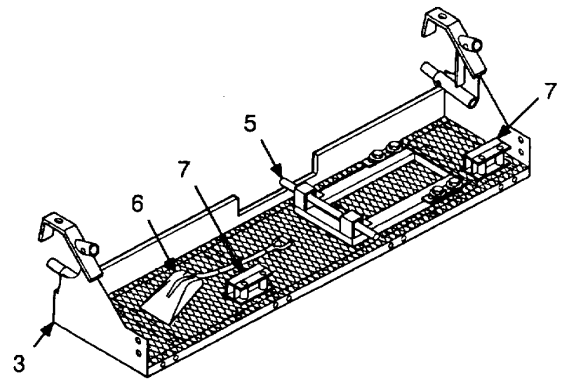

- (21) Place truck hitch (5), shovel (6), and two spacers (7) in operator's platform (3) approximately as shown.

- (17) Secure lifting slings or chains to grating inside operator's platform (3).

WARNING

Keep clear of equipment when it is being raised and lowered. Do not allow heavy components to swing while suspended by a lifting device. Exercise extreme caution when working near a cable under tension. Failure to follow this warning may result in severe injury or death to personnel.

NOTE

Two people should balance operator's platform while the third person operates lifting device.

- (18) Using a suitable lifting device, lift operator's platform (3) (125 lb) and place in hopper. Telescopic pipes (57) should face front of hopper. After operator's platform is positioned inside hopper, remove lifting slings or chains from grating.

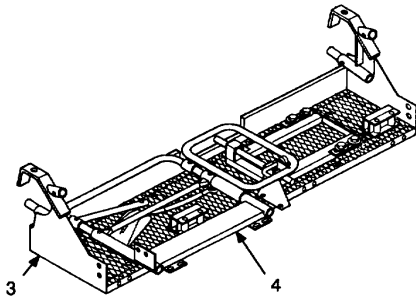

- (22) Place right-hand rail (4) in operator's platform (3) approximately as shown.

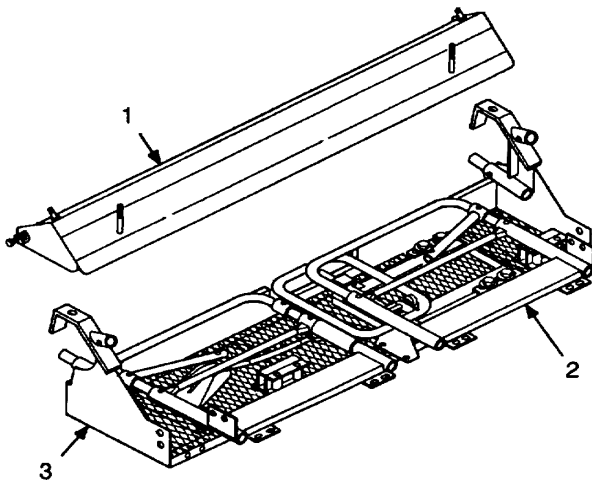

- (23) Place left-hand rail (2) in operator's platform (3) approximately as shown.
- (24) Place chute (1) in operator's platform (3) as shown.
- (25) Secure all items to operator's platform (3) using sufficient tiedown straps to prevent movement.

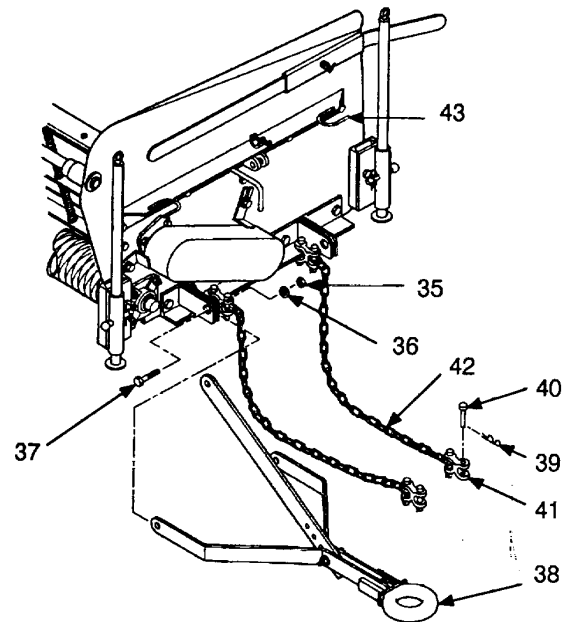

- (26) Remove hair pin (39) and pin (40) from clevis (41). Unwrap safety chain (42) from hooks (43), then install pin and hair pin in clevis.
- (27) Repeat step (26) for remaining safety chain.
- (28) Remove mounting hardware stowed on transport tongue (38).
- (29) Install transport tongue (38) on hopper using three screws (37), new lockwashers (36), and nuts (35). Tighten transport tongue mounting bolts to 120 lb-ft.
- (30) Install taillights on spreader (para 4-11).

4-13. INSTALLING AND REMOVING TRUCK HITCH.

This task covers:

a. Removal

b. Installation

INITIAL SETUP:

Tools:

Tool Kit, General Mechanic's Automotive
Torque wrench

Materials/Parts

Four lockwashers
Personnel Required: Two

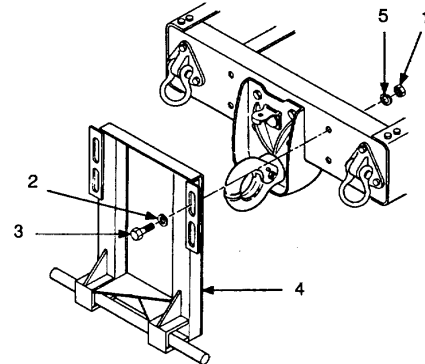
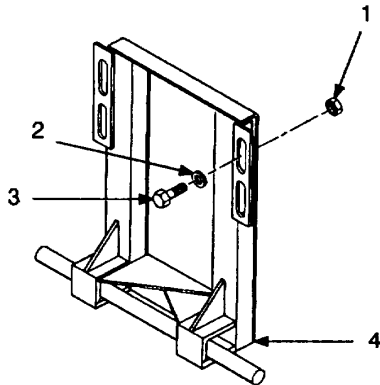

a. *Installing Truck Hitch on Dump Truck.*

- (1) Remove four nuts (1), flatwashers (2), and bolts (3) stowed on truck hitch (4).

NOTE

If spreader is used with M51A2, M817, M929, or M930 dump truck, perform steps (2) and (15). If spreader is used with M929A1, M929A2, M930A1, or M930A2 dump truck, perform steps (3) through (15).

- (2) Install truck hitch (4) on rear crossmember of dump truck using four bolts (3), flatwashers (2), new lockwashers (5), and nuts (1). Tighten truck hitch mounting bolts to 60 lb-ft.
- (3) Stow mounting bolts (3) removed from truck hitch (4) in spreader toolbox.

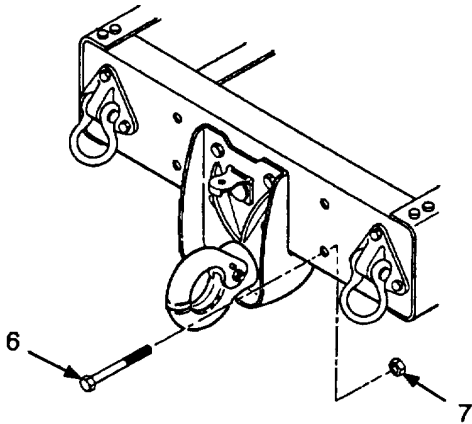

- (4) If equipped, remove four bolts (6) and nuts (7) from rear crossmember of dump truck.

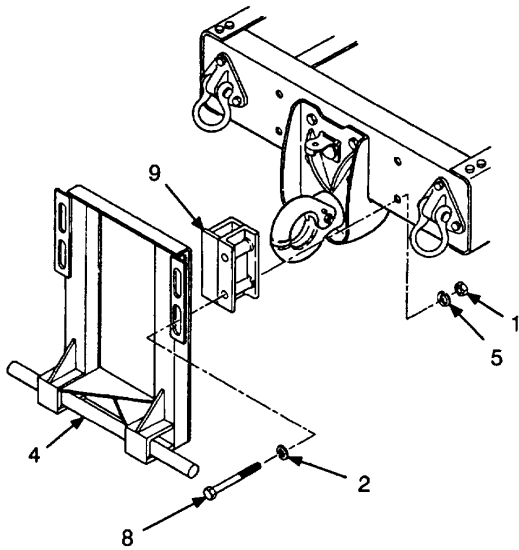

- (5) Remove four 8-1 in. mounting bolts (8) from spreader toolbox.
- (6) Install truck hitch (4) and two spacers (9) on rear crossmember of dump truck using four bolts (8), flatwashers (2), new lockwashers (5), and nuts (1). Tighten truck hitch mounting bolts to 60 lb-ft.

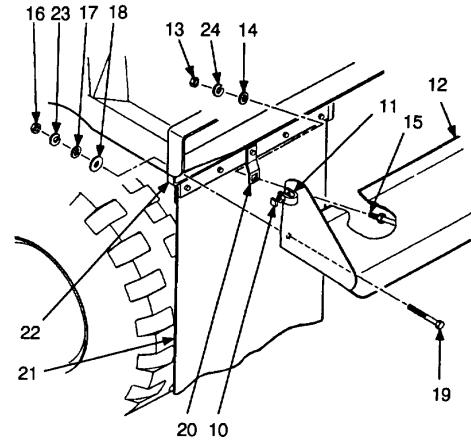

- (7) Fully loosen bolt (10) in each C-clamp (11) on chute (12).
- (8) Remove outer nut (13) and flatwasher (14) from each bolt (15) welded to chute (12). Do not remove inner nuts from bolts.
- (9) Remove two nuts (16), four flatwashers (17 and 18), and two bolts (19) from chute (12).
- (10) Position chute (12) for installation on dump truck. Ensure that bolts (15) welded to chute enter brackets (20) behind tire flaps (21).
- (11) Install bolt (19) through chute (12) and bracket (22). Secure bolt using large flatwasher (18), small flatwasher (17), new lockwasher (23), and nut (16).
- (12) Repeat step (11) on other side of chute (12).
- (13) Install flatwasher (14), new lockwasher (24), and nut (13) on each of the two bolts (15) welded to chute (12).
- (14) Tighten bolt (10) in each C-clamp (11) on chute (12).
- (15) Install operator's platform on spreader (para 4-14).

4-13. INSTALLING AND REMOVING TRUCK HITCH (CONT).

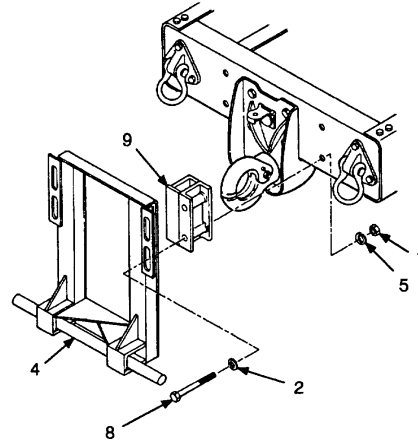
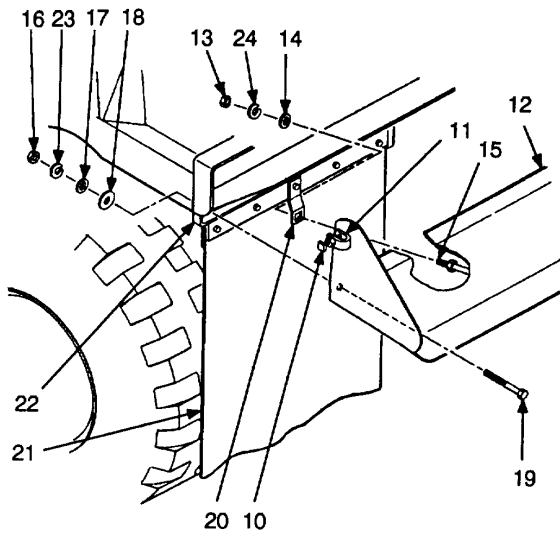

b. *Removing Truck Hitch from Dump Truck.*

NOTE

If spreader was used with M929A1, M929A2, M930A1, or M930A2 dump truck, perform steps (1) through (9) and (12). If spreader was used with M51A2, M817, M929, or M930 dump truck, perform steps (10) through (13).

- (1) Loosen bolt (10) in each C-clamp (11) on chute (12).
- (2) Remove two nuts (16), lockwashers (23), four flatwashers (17 and 18), and two bolts (19) securing chute (12) to brackets (22). Discard lockwashers.
- (3) Remove outer nut (13), lockwasher (24), and flatwasher (14) from each of the bolts (15) welded to chute (12). Do not remove inner nuts from bolts. Discard lockwashers.
- (4) Remove chute (12) from dump truck bed.
- (5) Stow chute mounting hardware on chute (12).

- (6) Remove four nuts (1), lockwashers (5), flatwashers (2), and bolts (8) securing truck hitch (4) and two spacers (9) to rear crossmember of dump truck. Remove truck hitch and two spacers. Discard lockwashers.
- (7) Stow four 8-1/2 in. mounting bolts (8) in spreader toolbox.

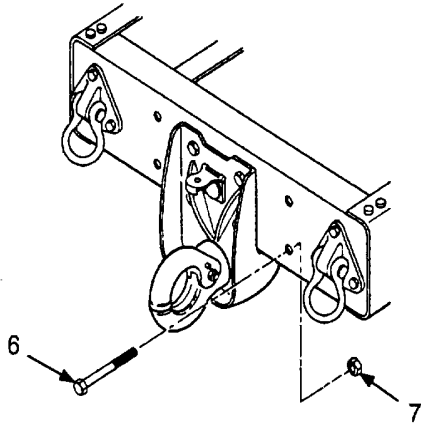

- (8) If necessary, remove four bolts (6) and nuts (7) from spreader toolbox and install in rear crossmember of dump truck.

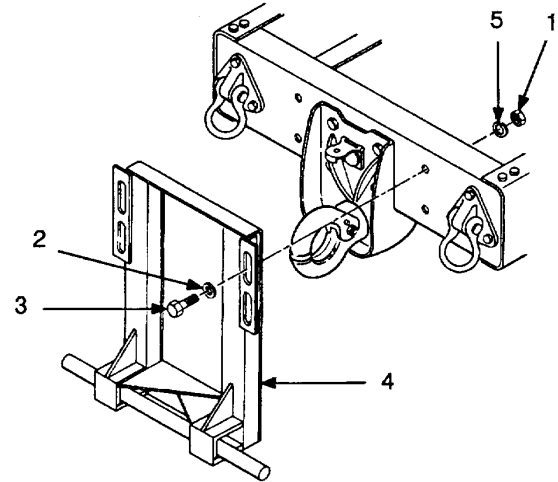

- (10) Remove four nuts (1), lockwashers (5), flatwashers (2), and bolts (3) securing truck hitch (4) to rear crossmember of dump truck. Remove truck hitch. Discard lockwashers.

- (11) Store truck hitch mounting hardware on truck hitch (4).

- (12) Remove operator's platform from spreader (para 4-14).

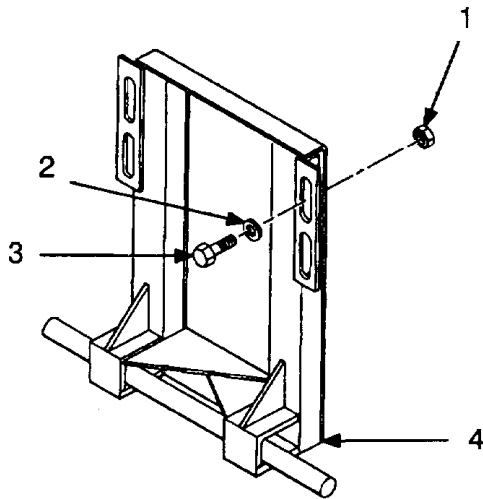

- (9) Remove four 4-in. truck hitch mounting bolts (3) from spreader toolbox. Stow mounting bolts (3), flatwashers (2), and nuts (1) on truck hitch (4).

4-14. INSTALLING AND REMOVING OPERATOR'S PLATFORM.

This task covers:

a. Removal

b. Installation

INITIAL SETUP:

Tools:

Tool Kit, General Mechanic's Automotive
Lifting device with 125 lb capacity
Lifting slings or chains
Torque wrench

Materials/Parts:

Tiedown straps (Item 12, Appendix E)
Fourteen lockwashers

Personnel Required: Three

a. *Installing Operator's Platform on Spreader.*

- (1) Remove nuts (1), lockwashers (2), and eyebolts (3) from hopper. Discard lockwashers.
- (2) Secure lifting slings or chains to grating inside operator's platform (4).

WARNING

Keep clear of equipment when it is being raised and lowered. Do not allow heavy components to swing while suspended by a lifting device. Exercise extreme caution when working near a cable under tension. Failure to follow this warning may result in severe injury or death to personnel.

NOTE

Two people should balance and position operator's platform while the third person operates lifting device.

- (3) Using a suitable lifting device, lift operator's platform (4) (125 lb) and position for installation on spreader.
- (4) Lower operator's platform (4) into position over rear of spreader. Holes in brackets (5) must align with holes for eyebolts (3).
- (5) Remove lifting slings or chains from operator's platform (4).

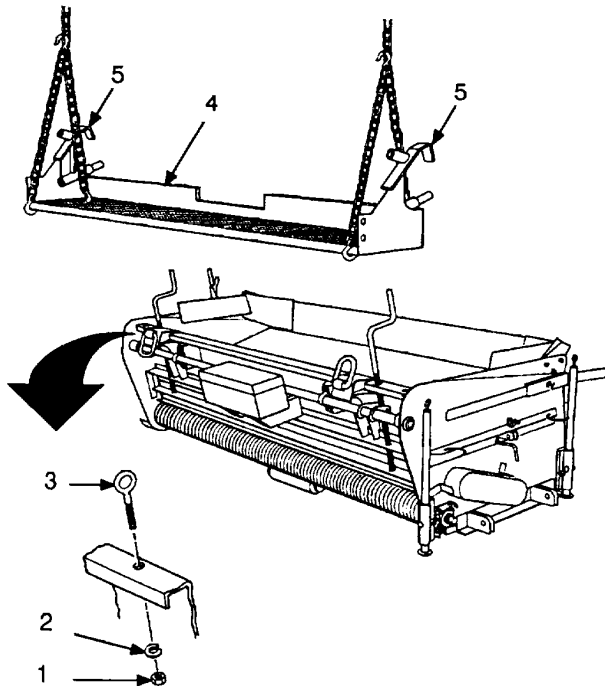

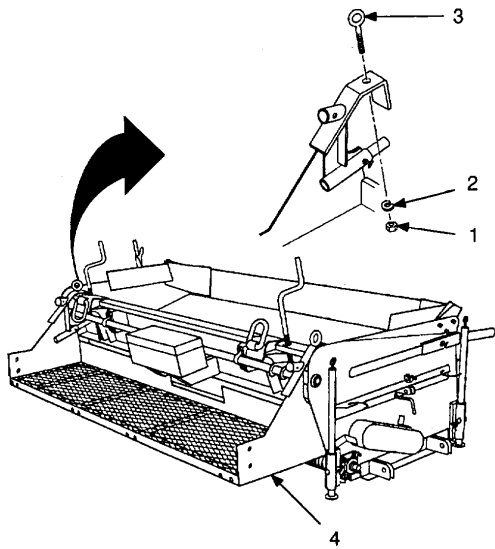

- (6) Install two eyebolts (3), new lockwashers (2), and nuts (1) to secure operator's platform (4) to hopper.

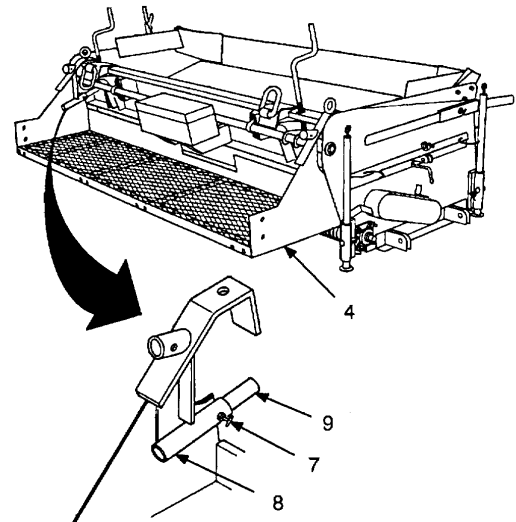

- (a) Loosen setscrew (7) in each housing (8).
- (b) Slide telescopic pipes (9) in or out of housings (8) until gate opens and closes freely. Tighten setscrews (7).
- (8) Tighten operator's platform mounting eyebolts (3) to 216 lb-ft. Ensure that openings in eyebolts face sides of spreader.

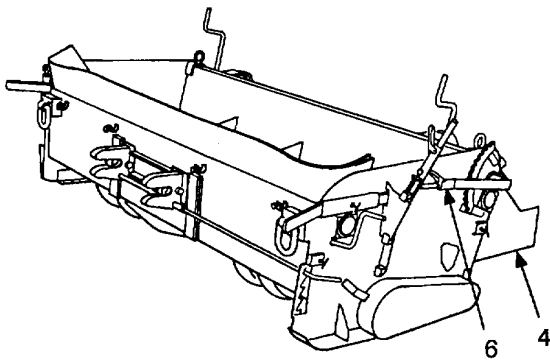

- (7) Using gate adjusting lever (6), open and close hopper gate. If there is any interference between operator's platform (4) and gate, adjust clearance as follows:

4-14. INSTALLING AND REMOVING OPERATOR'S PLATFORM (CONT).

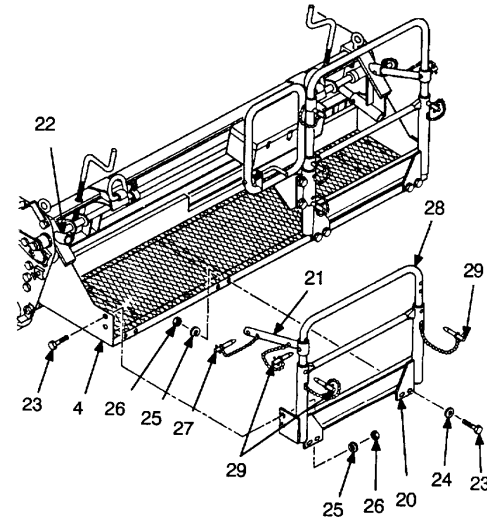
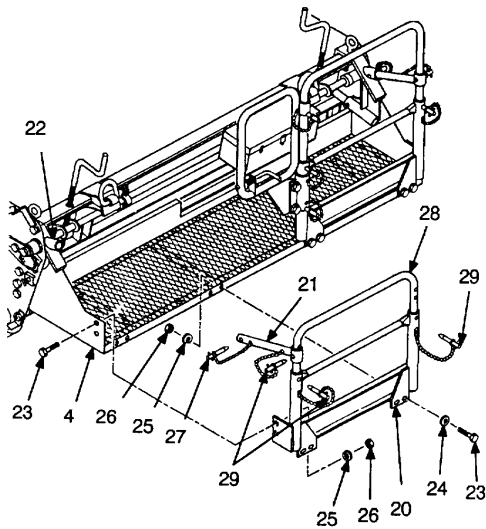

- (9) Remove mounting hardware stowed on right-hand frame support (10).
- (10) Position frame support (10) for installation on operator's platform (4). Ensure that support bracket (11) enters tube (12).

NOTE

Four screws mount frame support to back of operator's platform. These screws require flatwashers. Two screws mount frame support to side of operator's platform. These screws do not require flatwashers.

- (11) Secure frame support (10) to back of operator's platform (4) using six screws (13), four flatwashers (14), six new lockwashers (15), and six nuts (16). Tighten frame mounting bolts to 60 lb-ft.
- (12) Secure support bracket (11) to tube (12) using quick-release pin (17).
- (13) Fully raise rail (18) and secure in position with five quick-release pins (19).

- (14) Remove mounting hardware stowed on left-hand frame support (20).
- (15) Position frame support (20) for installation on operator's platform (4). Ensure that support bracket (21) enters tube (22).

NOTE

Four screws mount frame support to back of operator's platform. These screws require flatwashers. Two screws mount frame support to side of operator's platform. These screws do not require flatwashers.

- (16) Secure frame support (20) to operator's platform (4) using six screws (23), four flatwashers (24), six new lockwashers (25), and six nuts (26). Tighten frame mounting bolts to 60 lb-ft.
- (17) Secure support bracket (21) to tube (22) using quick-release pin (27).
- (18) Fully raise rail (28) and secure in position with three quick-release pins (29).
- (19) Couple spreader to dump truck (para 4-15).

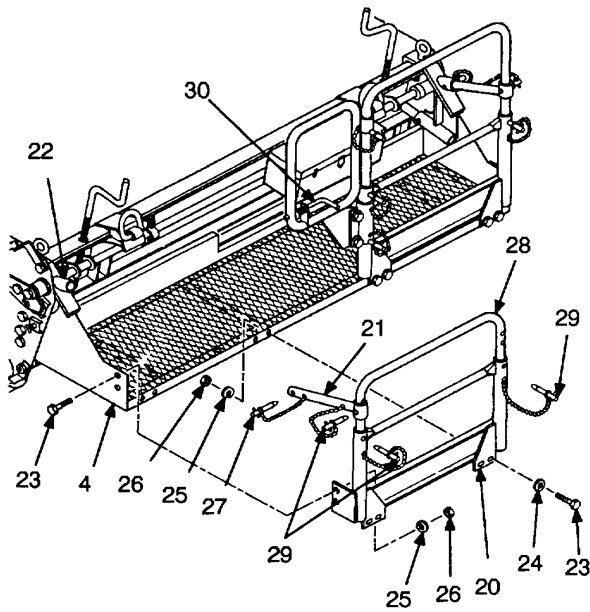

- (5) Remove quick-release pin (29) securing support bracket (21) to rail (28). Swing support bracket towards center of rail and secure in place with quick-release pin.

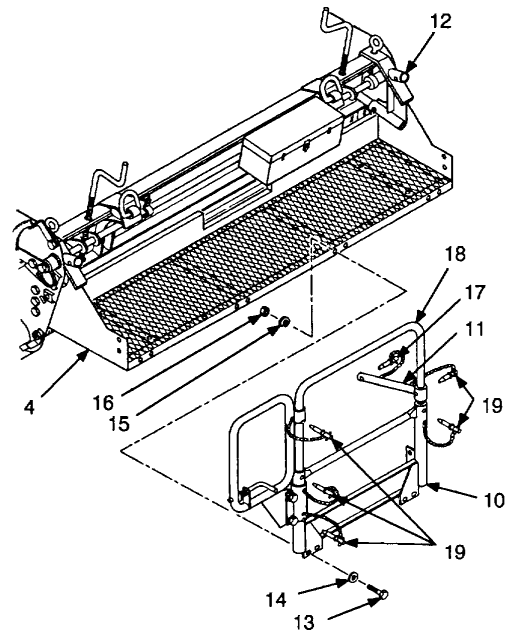

- (6) On right side of operator's platform (4), remove five quick-release pins (19) and push rail (18) into frame support (10).
- (7) Remove quick-release pin (17) securing support bracket (11) to tube (12).
- (8) Remove six nuts (16), lockwashers (15), screws (13), and four flatwashers (14) securing frame support (10) to operator's platform (4). Remove frame support. Discard lockwashers and stow remaining mounting hardware on frame support.

b. *Removing Operator's Platform from Spreader.*

- (1) Disengage latch handle (30) from left-hand rail (28).
- (2) On left side of operator's platform (4), remove three quick-release pins (29) and push rail (28) into frame support (20). Secure in lowered position using three quick-release pins.
- (3) Remove quick-release pin (27) securing support bracket (21) to tube (22).
- (4) Remove six nuts (26), lockwashers (25), screws (23), and four flatwashers (24) securing frame support (20) to operator's platform (4). Remove frame support. Discard lockwashers and stow remaining mounting hardware on frame support.

4-14. INSTALLING AND REMOVING OPERATOR'S PLATFORM (CONT).

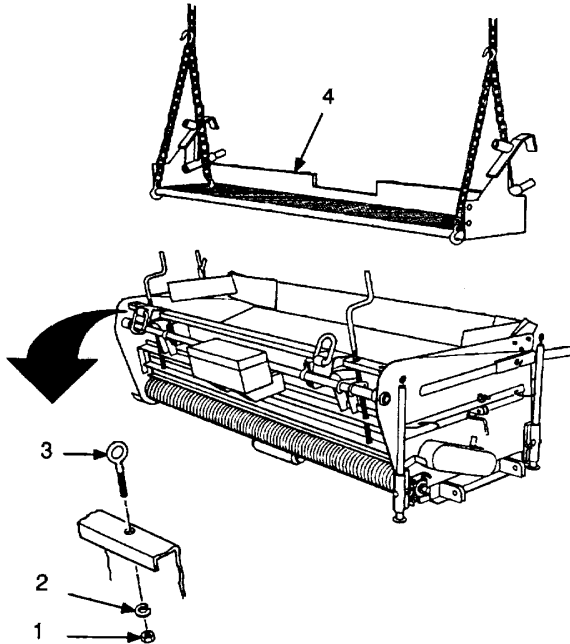

- (9) Remove two nuts (1), lockwashers (2), and eyebolts (3) securing operator's platform (4) to hopper.
- (10) Secure lifting slings or chains to grating inside operator's platform (4).

WARNING

Keep clear of equipment when it is being raised and lowered. Do not allow heavy components to swing while suspended by a lifting device. Exercise extreme caution when working near a cable under tension. Failure to follow this warning may result in severe injury or death to personnel.

NOTE

Two people should balance operator's platform while the third person operates lifting device.

- (11) Using a suitable lifting device, remove operator's platform (4) (125 lb) from hopper and place on the ground. Remove lifting slings or chains from operator's platform.
- (12) Stow eyebolts (3), lockwashers (2), and nuts (1) in hopper where they mount the operator's platform.
- (13) Install transport truck and tongue on spreader (para 4-12).

4-15. COUPLING AND UNCOUPLING SPREADER.

This task covers: a. Coupling Spreader to Dump Truck b. Uncoupling Spreader from Dump Truck

INITIAL SETUP

Tools:

Tool Kit, General Mechanic's Automotive

Materials/Parts:

Tiedown straps (Item 12, Appendix E)

Personnel Required: Four

a. Coupling Spreader to Dump Truck.

WARNING

Do not stand between spreader and dump truck when dump truck is in motion. Ensure that dump truck has come to a complete stop before operating any spreader controls. Failure to follow this warning could result in severe injury or death.

(1) Back dump truck to spreader.

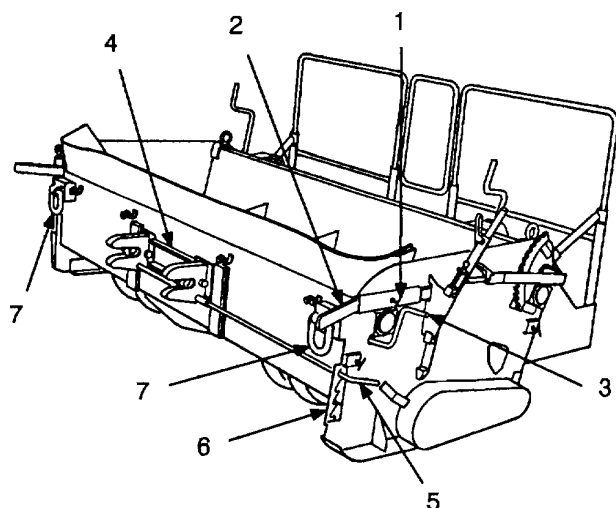

NOTE

Two people should pull spreader into position using balancing handles. Two people should lift spreader from rear.

(2) Loosen thumbscrews (1) and extend balancing handles (2). Use handles to hold spreader

level and position spreader while it is being coupled to dump truck.

CAUTION

Do not force hitch adjusting crank beyond its limits of travel. Failure to follow this caution could cause universal joint to jam.

(3) Using hitch adjusting crank (3), raise or lower coupler hitch (4) to match truck hitch. While raising or lowering coupler hitch, keep an eye on latch lever (5). If latch lever starts to bind, release it from support (6) and place in a higher or lower tooth on support.

WARNING

Ensure that both latches in coupler hitch lock onto shaft of truck hitch. If both latches do not lock onto truck hitch, spreader could break away from towing vehicle, causing severe injury or death to spreader operator.

(4) When coupler hitch (4) is at proper height, pull spreader into position using handles (2). Rotate latch lever (5) upward to open coupler hitch. When coupler hitch is seated on truck hitch, release latch lever to lock coupler hitch on truck hitch.
 (5) Push handles (2) fully into guides and tighten thumbscrews (1).
 (6) Check for possible interference between D-rings (7) at front of spreader and dump truck tires. If necessary, secure D-rings to prevent movement using tiedown straps.

14-15. COUPLING AND UNCOUPLING SPREADER (CONT).

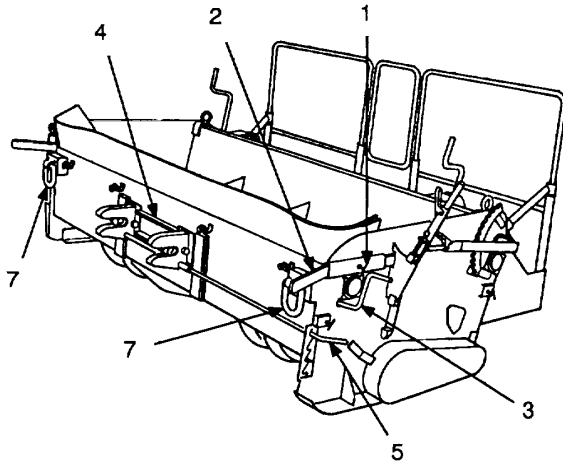

b. Uncoupling Spreader from Dump Truck.

- (1) Loosen thumbscrews (1) and extend balancing handles (2). Use handles to hold spreader level and position spreader while it is being uncoupled.

WARNING

Ensure that both latches in coupler hitch release. If both latches do not release, spreader will move forward with dump truck. Failure to follow this warning could result in severe injury or death.

NOTE

Two people should hold spreader level using balancing handles. Two people should support spreader from rear.

- (2) Rotate latch lever (5) upward to release coupler hitch (4) from truck hitch. Ensure that coupler hitch is fully released before continuing.

WARNING

Do not stand between spreader and dump truck when dump truck is in motion. Failure to follow this warning could result in severe injury or death.

- (3) Have truck driver drive slowly forward and away from spreader. If coupler hitch (4) binds on truck hitch, raise or lower coupler hitch using hitch adjusting crank (3) until spreader can be uncoupled.
- (4) Carefully allow spreader to tilt backward until it rests on ground.
- (5) Push handles (2) fully into guides and tighten thumbscrews (1).
- (6) If necessary, cut and remove tiedown straps securing D-rings (7).
- (7) Remove truck hitch from dump truck (para 4-13).

Section V. UNIT MAINTENANCE PROCEDURES

4-16. TAILLIGHT REPAIR.

This task covers: a. Lamp Replacement c. Installation
 b. Removal

INITIAL SETUP

Tools:

Tool Kit, General Mechanic's Automotive

Materials/Parts:

Marker tags (Item 13, Appendix E)
 Three lockwashers (removal and installation only)

Equipment Conditions:

Reference

- Para 4-11 Wiring harness disconnected from towing vehicle.
 Para 4-11 Taillights removed from spreader (removal and installation only).

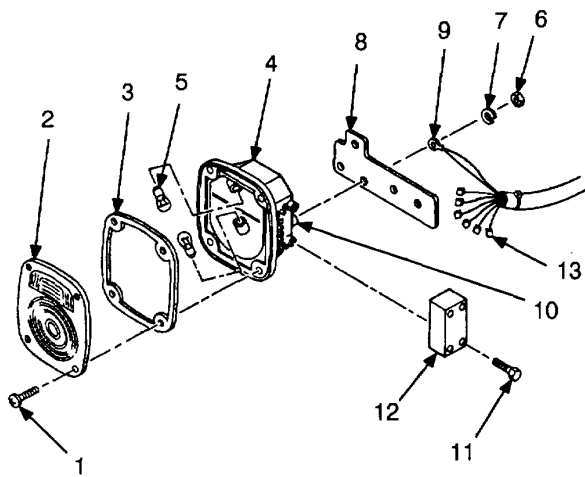

a. Lamp Replacement.

- (1) Remove four screws (1), lens (2), and gasket (3) from taillight (4).
- (2) Remove defective lamp (5) from taillight (4). Discard lamp.
- (3) Install new lamp (5) in taillight (4).
- (4) Install gasket (3) and lens (2) on taillight (4) using four screws (1).

b. Removal.

NOTE

The following procedure can be used for either tail- light. Left-hand taillight is illustrated. Left-hand tail- light has six electrical leads. Right-hand taillight has three electrical leads.

- (1) Remove three nuts (6) and lockwashers (7) securing bracket (8) to taillight (4). Remove ground lead (9) and bracket from studs (10) on back of taillight. Discard lockwashers.
 - (2) Remove four screws (11) and cover (12) from taillight (4).
 - (3) Tag wires (13) connected to taillight (4). Pull wires off terminals and remove.
- c. Installation.

- (1) Connect wires (13) to terminals. Remove tags.
- (2) Install cover (12) on taillight (4) using four screws (11).
- (3) Install bracket (8) on back of taillight (4). Install ground lead (9) over one stud (10), then install three nuts (6) and new lockwashers (7) to secure bracket to taillight.

FOLLOW-ON MAINTENANCE:

- Install taillights on spreader (para 4-11).
- Connect wiring harness to towing vehicle and operation of taillights.

4-17. WIRING HARNESS REPAIR.

This task covers:

- a. Removal
- b. Connector Plug Replacement
- c. Installation

INITIAL SETUP*Tools:*

Tool Kit, General Mechanic's Automotive
Soldering gun

Materials/Parts:

Insulation tape (Item 14, Appendix E)
Marker tags (Item 13, Appendix E)
Solder (Item 10, Appendix E)
Two lockwashers

References:

TB SIG 222

Equipment Conditions:

Reference

Para 4-11 Wiring harness disconnected from tow-
ing vehicle.

a. *Removal.*

- (1) Remove four screws (1) and cover (2) from each taillight (3).

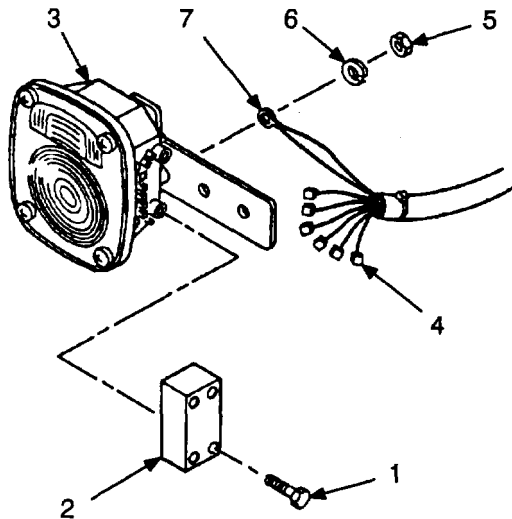
**NOTE**

Left-hand taillight has six electrical leads. Right-hand taillight has three electrical leads.

- (2) Tag wires (4). Pull wires off terminals.
- (3) At back of each taillight, remove nut (5) and lockwasher (6) securing ground lug (7) to stud. Remove ground lug from stud and remove wiring harness. Discard lockwashers.

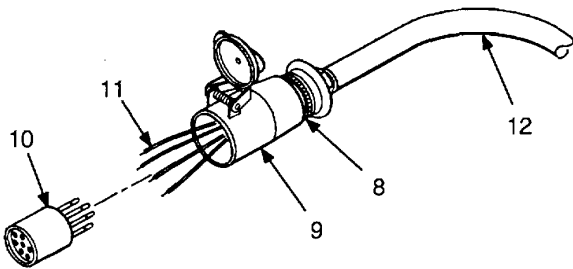

b. Connector Plug Replacement.

- (1) Remove clamp (8) on shell (9). Slide shell back from insert (10).

NOTE

For detailed instructions on soldering and unsoldering, refer to TB SIG 222.

- (2) Tag wires (11). Unsolder wires from contacts and remove

- (3) Remove shell (9) from wiring harness (12).

NOTE

Refer to Appendix G for wiring harness fabrication.

- (4) Slide new shell (9) over wiring harness (12).
- (5) Solder wires (11) to contacts in new insert (10). Remove tags.
- (6) Slide shell (9) over insert (10) and secure with clamp (8).

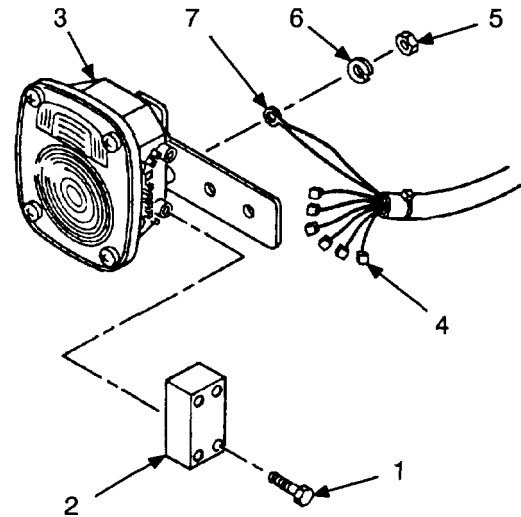

c. *Installation.*

- (1) Install ground lug (7) on each taillight (3) using new lockwasher (6) and nut (5).

NOTE

Left-hand taillight has three electrical leads.

- (2) Push wires (4) onto terminals and remove tags.
- (3) Install cover (2) on each taillight (3) using four screws (1).

FOLLOW-ON MAINTENANCE:

- Install taillights on spreader (para 4-11).
- Connect wiring harness to towing vehicle and Check operation of taillights.

4-18. TRANSPORT TRUCK AXLE REPLACEMENT.

This task covers:

a. Removal

b. Installation

INITIAL SETUP

Tools:

Tool Kit, General Mechanic's Automotive
Torque wrench

Materials/Parts:

Two lockwashers

Equipment Conditions:

Para 4-12

Spreader removed from transport truck.

Para 4-20

Transport truck hub removed from axle being replaced.

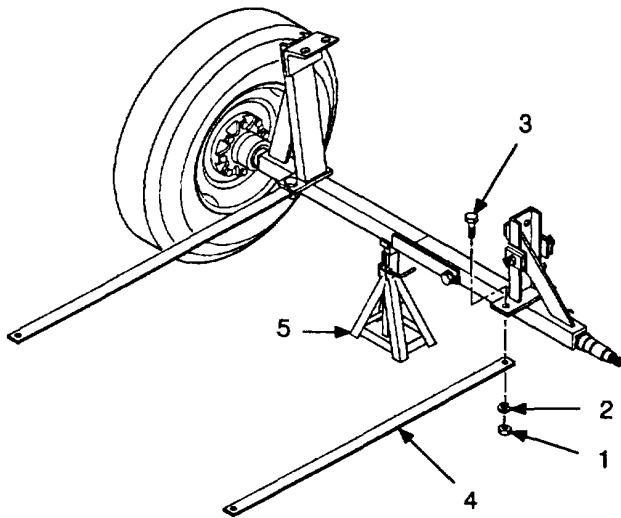

a. *Removal.*

NOTE

This procedure can be used for either axle.

- (1) Remove nut (1), lockwasher (2), and screw (3) securing bracket (4) to axle being re placed. Remove bracket. Discard lock- washer.
- (2) Remove trestle (5).

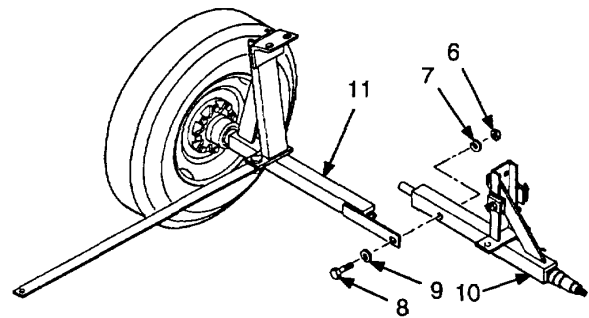

- (3) Remove nut (6), lockwasher (7), screw (8), and flatwasher (9) securing left-hand axle (10) to right-hand axle (11). Separate two axles and remove axle being replaced. Discard lockwasher.
- b. *Installation.*

- (1) Assemble two axles (10 and 11) and secure using screw (8), flatwasher (9), new lock- washer (7), and nut (6). Tighten screw to 120 lb-ft.
- (2) Support axles with trestle (5).
- (3) Install bracket (4) on axle using screw (3), new lockwasher (2), and nut (1). Tighten bracket mounting screw to 60 lb-ft.

FOLLOW-ON MAINTENANCE:

- Install transport truck wheel hub (para 4-20) and wheel (para 4-19).
- Install transport truck on spreader (para 4-12).

4-19. TRANSPORT TRUCK WHEEL REPLACEMENT.

This task covers:

a. Removal

b. Installation

INITIAL SETUP

Tools:

- Tool Kit, General Mechanic's Automotive
- Torque wrench
- 12-ton hydraulic jack

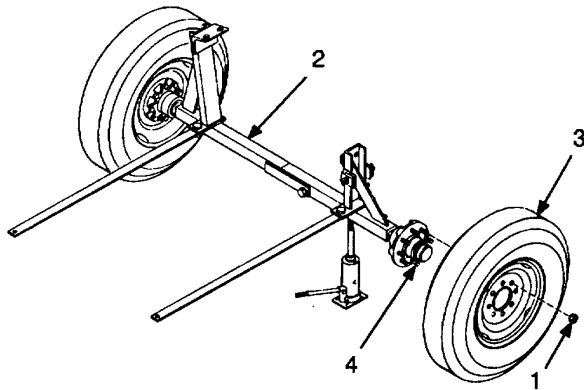

- (3) Remove eight wheel nuts (1).
 - (4) Remove wheel (3) from bolts (4).
 - (4).
- b. *Installation.*
- (1) Install wheel (3) on bolts (4).
 - (2) Install eight wheel nuts (1) finger tight.
 - (3) Lower hydraulic jack until wheel (3) is on ground. Remove hydraulic jack.

a. Removal.

NOTE

This procedure can be performed with the spreader installed on the transport truck or with the spreader removed from the transport truck.

- (1) Loosen eight wheel nuts (1).
- (2) Using hydraulic jack, support transport truck axle (2) near wheel being removed. Raise axle until wheel (3) is off ground.

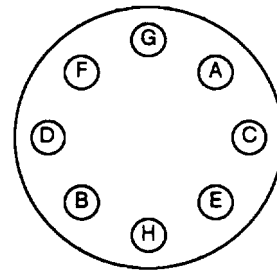

- (4) Tighten eight wheel nuts (1) to 50 lb-ft in the pattern shown.

4-20. TRANSPORT TRUCK WHEEL HUB REPAIR.

This task covers:

- a. Removal
- b. Disassembly
- c. Assembly
- d. Installation

INITIAL SETUP

Tools:

Tool Kit, General Mechanic's Automotive Shop Equipment, Automotive Maintenance and Repair, Organizational Maintenance, Common No. Motor vehicle maintenance trestle

References:

TM 9-214

Equipment Conditions:

References

Para 4-19 Transport truck wheel removed.

Materials/Parts:

One cotter pin
One seal

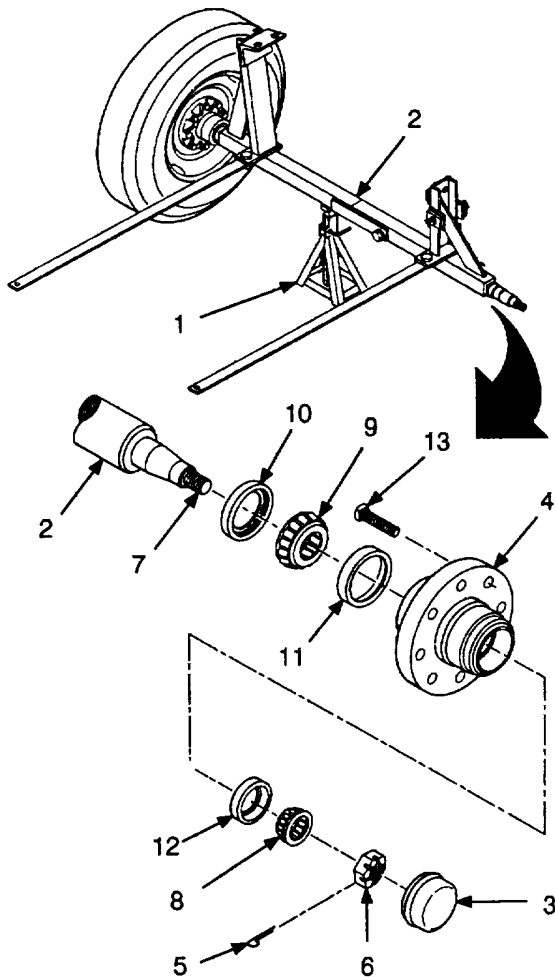

a. *Removal.*

- (1) Position trestle (1) under axle (2) and remove hydraulic jack.
- (2) Remove cap (3) from hub (4).
- (3) Remove cotter pin (5) from nut (6) and spindle (7). Discard cotter pin.
- (4) Remove nut (6) from spindle (7).
- (5) Pull hub (4) out slightly to loosen outer wheel bearing cone (8). Remove outer wheel bearing cone and hub from spindle (7).

b. *Disassembly.*

- (1) Tap inner wheel bearing cone (9) and seal (10) out of hub (4). Discard seal.
- (2) Clean and Inspect inner and outer wheel bearing cones (8 and 9) in accordance with TM 9-214. Discard if damaged.

NOTE

If wheel bearing cones require replacement, bearing cups must also be replaced. Do the following step only if bearing cups require replacement.

- (3) Remove inner (11) and outer (12) bearing cups from hub. Discard bearing cups.
- (4) If damaged, remove eight bolts (13) from hub (4).

c. *Assembly.*

- (1) If necessary, install eight bolts (13) in hub (4).
- (2) If necessary, tap new Inner (1) and outer (12) bearing cups into hub (4).

NOTE

Pack wheel bearing cones with grease in accordance with TM 9-214.

- (3) Pack inner wheel bearing cone (9) with grease. Install inner wheel bearing cone and new seal (10) in hub (4).

d. *Installation.*

- (1) Install hub (4) on spindle (7).
- (2) Pack outer wheel bearing cone (8) with grease and install on spindle (7).
- (3) Install nut (6) on spindle (7). Turn hub (4) by hand and tighten nut until hub drags. Loosen nut so that hub turns freely.
- (4) Secure nut (6) to spindle (7) using new cotter pin (5).
- (5) Install cap (3) on hub (4).
- (6) Position hydraulic jack under axle (2) and raise enough to remove trestle (1).

FOLLOW-ON MAINTENANCE:

- Install transport truck wheel (para 4-19).

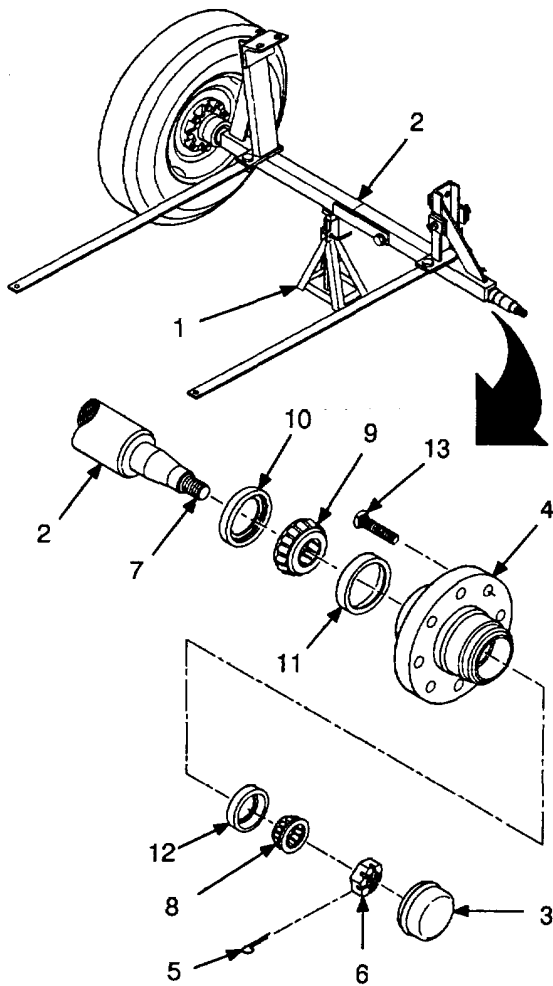

4-21. TIRES AND TUBES REPAIR.

Refer to TM 9-2610-200-14 for tire and tube repair.

4-22. OPERATOR'S PLATFORM REPAIR.

This task covers: a. Disassembly c. Assembly
 b. Cleaning and Inspection

INITIAL SETUP

Tools:

Tool Kit, General Mechanic's Automotive
 Torque wrench

Materials/Parts:

Dry cleaning solvent (Item 11, Appendix E)
 One cotter pin
 Two lockwashers

Equipment Conditions:

Reference
 Para 4-14

Operator's platform removed from
 spreader.

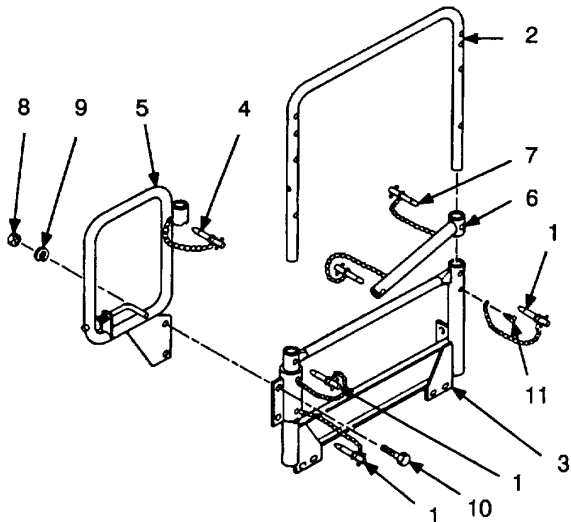

- (2) Remove quick-release pin (4) securing gate (5) to rail (2).
- (3) Pull rail (2) up and out of frame support (3). Support bracket (6) will come off with rail.
- (4) Remove quick-release pin (7) securing support bracket (6) to rail (2). Remove support bracket from rail.
- (5) Remove two nuts (8), lockwashers (9), and screws (10) securing gate (5) to frame support (3). Remove gate. Discard lockwashers.

NOTE

All of the quick-release pins are removed the same way. Step (6) is for one quick-release pin. Repeat as necessary for the other quick-release pins.

- (6) Remove screw (11) securing quick-release pin (1) to frame support (3). Remove quick-release pin.

a. Disassembly.

NOTE

Step (1) through (7) are for right-hand frame support and rail.

- (1) Remove three quick-release pins (1) securing rail (2) to frame support (3).

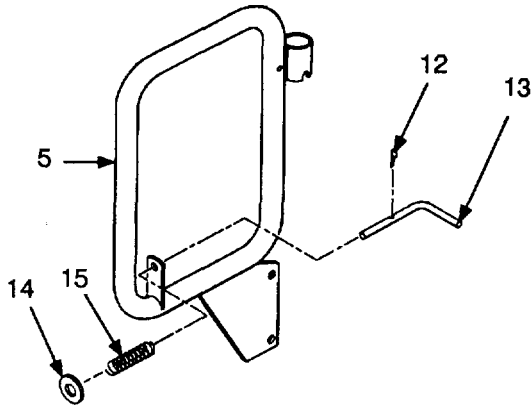

- (7) Remove cotter pin (12) from handle (13). Remove handle, flatwasher (14) and spring (15) from gate (5). Discard cotter pin.

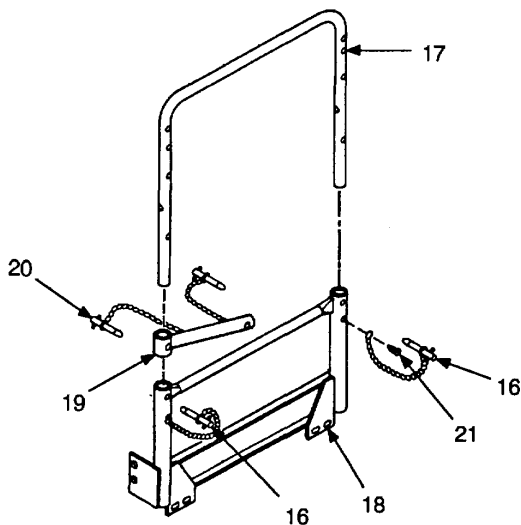

NOTE

Steps (8) through (11) are for left-hand frame support and rail.

- (8) Remove two quick-release pins (16) securing rail (17) to frame support (18).
- (9) Pull rail (17) up and out of frame support (18). Support bracket (19) will come off with rail.
- (10) Remove quick-release pin (20) securing support bracket (19) to rail (17). Remove support bracket from rail.

NOTE

All of the quick-release pins are removed the same way. Step (11) is for one quick-release pin. Repeat as necessary for the other quick-release pins.

- (11) Remove screw (21) securing quick-release pin (16) to frame support (18). Remove quick-release pin.

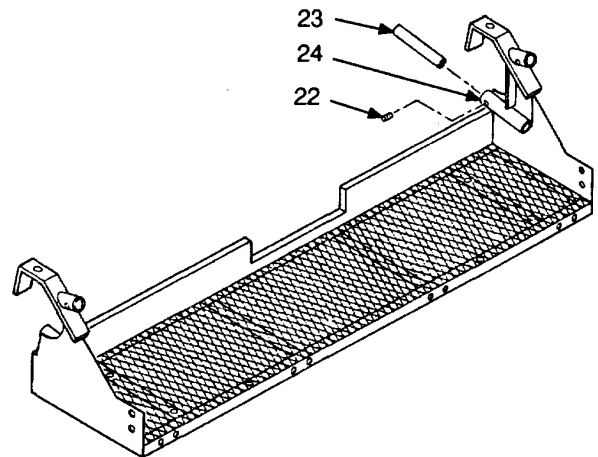

- (12) Loosen setscrew (22) and remove pipe (23) from each housing (24).
- b. Cleaning and Inspection.

WARNING

Dry cleaning solvent P-D-680 is toxic and flammable. Wear protective goggles, face mask, and gloves and use in a well ventilated area. Avoid contact with skin, eyes, and clothes and do not breath vapors. Do not use near open flame or excessive heat. The flash point for Type I solvent is 100 degrees F (38 degrees C). The flash point for Type II solvent is 140 degrees F (60 degrees C). If you become dizzy while using cleaning solvent, get fresh air immediately and get medical aid. If contact with eyes is made, wash your eyes with water and get medical aid immediately.

- (1) Clean all parts with dry cleaning solvent and dry thoroughly.
 - (2) Inspect all parts for cracks, breaks, or other damage. Replace all damaged parts.
- c. Assembly.
- (1) Install pipe (23) In housing (24) and tighten setscrew (22). Repeat for other side.

4-22. OPERATOR'S PLATFORM REPAIR (CONT).

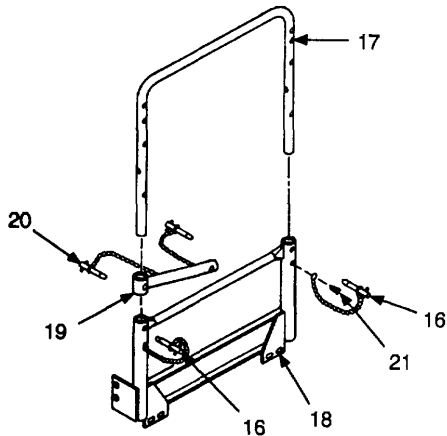

NOTE

- Steps (2) through (4) are for the left-hand frame support and rail.
- All of the quick-release pins are installed the same way. Step (2) is for one quick-release pin. Repeat as necessary for the other quick-release pins.

- (2) Install quick-release pin (16) using screw (21).
- (3) Slide support bracket (19) over rail (17). Secure support bracket to rail using quick-release pin (20)
- (4) Push rail (17) into frame support (18) and secure in lowest position using two quick-release pins (16).

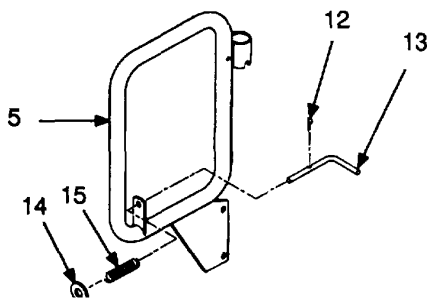

NOTE

Steps (5) through (9) are for right-hand frame support and rail.

- (5) Install spring (15), flatwasher (14), and handle (13) on gate (5) and secure with new cotterpin (12).

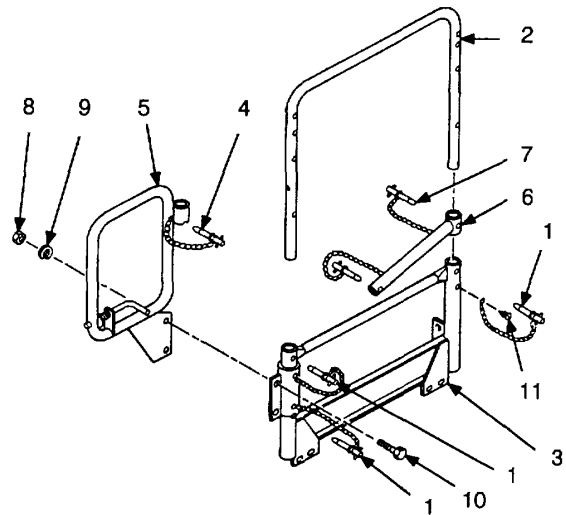

NOTE

All of the quick-release pins are installed the same way. Step (6) is for one quick-release pin. Repeat as necessary for the other quick-release pins.

- (6) Install quick-release pin (1) on frame support (3) using screw (11).
- (7) Install gate (5) on frame support (3) using two screws (10), new lockwashers (9), and nuts (8). Tighten gate mounting screws to 25 lb-ft.
- (8) Slide support bracket (6) onto rail (2). Secure support bracket to rail using quick-release pin (7).
- (9) Slide rail (2) through gate (5) and into frame support (3).

FOLLOW-ON MAINTENANCE:

- If spreader is being prepared for use, install operator's platform on spreader (para 4-14). If spreader is being prepared for transport or storage, stow operator's platform in hopper (para 4-12).

4-23. TRANSPORT TONGUE AND MOUNTING COMPONENTS REPLACEMENT.

This task covers:

- | | |
|----------------------------|-----------------|
| a. Removal | d. Assembly |
| b. Disassembly | e. Installation |
| c. Cleaning and Inspection | |

INITIAL SETUP*Tools:*

Tool Kit, General Mechanic's Automotive
Torque wrench

Materials/Parts:

Dry cleaning solvent (Item 11, Appendix E)
Six cotter pins
Twelve lockwashers

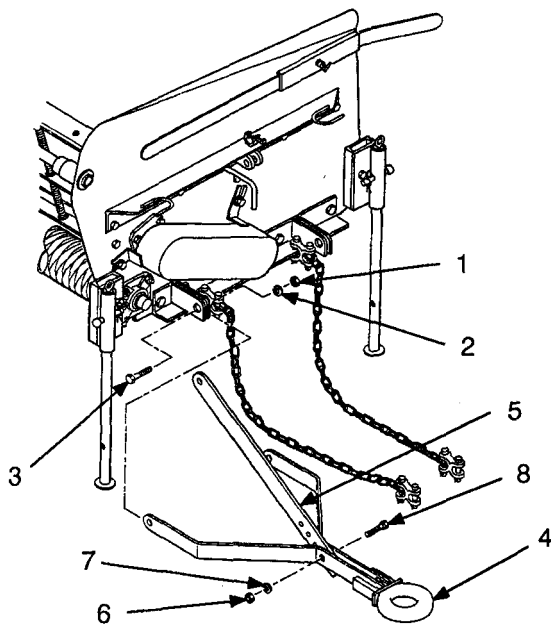
*a. Removal.*

- (1) Remove three nuts (1), lockwashers (2), and screws (3). Remove drawbar (4) and lift bar (5) from spreader. Discard lockwashers.
- (2) Remove nut (6), lockwasher (7), and screw (8). Remove lift bar (5) from drawbar (4). Discard lockwasher.

4-23. TRANSPORT TONGUE AND MOUNTING COMPONENTS REPLACEMENT (CONT)

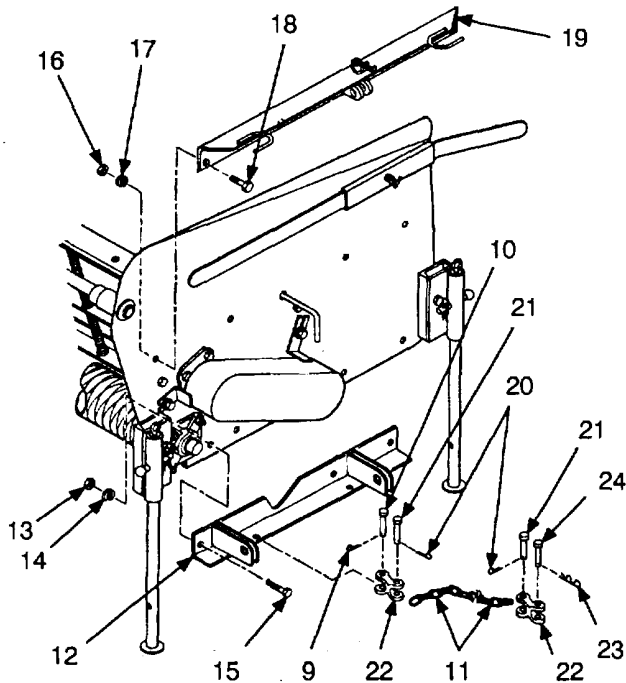

- (3) Remove cotter pin (9) and pin (10) securing each safety chain (11) to angle (12). Remove safety chains. Discard cotter pins.
- (4) Remove four nuts (13), lockwashers (14), and screws (15). Remove angle (12) from spreader. Discard lockwashers.
- (5) Remove four nuts (16), lockwashers (17), and screws (18). Remove frame section (19) from spreader. Discard lockwashers.

b. *Disassembly.*

- (1) Remove cotter pin (20) and pin (21) securing clevises (22) to each end of safety chain (11). Remove clevises. Discard cotter pins.
- (2) Remove hair pin (23) and pin (24) from front clevises (22).
- (3) Repeat steps (1) and (2) for remaining safety chain.

c. *Cleaning and Inspection.***WARNING**

Dry cleaning solvent P-D-680 is toxic and flammable. Wear protective goggles, face mask, and gloves and use in a well ventilated area. Avoid contact with skin, eyes, and clothes and do not breath vapors. Do not use near open flame or excessive heat. The flash point for Type I solvent is 100 degrees F (38 degrees C). The flash point for Type II solvent is 140 degrees F (60 degrees C). If you become dizzy while using cleaning solvent, get fresh air immediately and get medical aid. If contact with eyes is made, wash your eyes with water and get medical aid immediately.

- (1) Clean all parts with dry cleaning solvent and dry thoroughly.
- (2) Inspect all parts for cracks, breaks, or damage. Replace all damaged parts.

nuts (16). Tighten frame section mounting screws to 60 lb-ft.

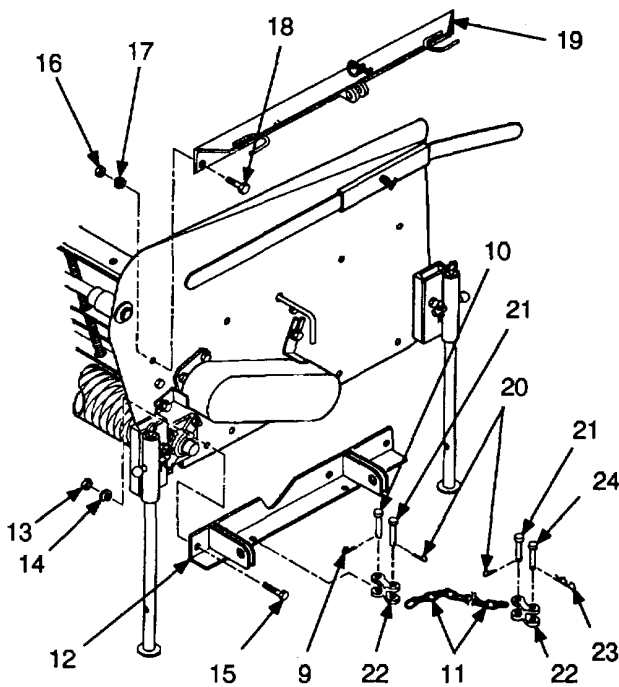

- (2) Install angle (12) on spreader using four screws (15), new lockwashers (14), and nuts (13). Tighten angle mounting screws to 60 lb-ft.
- (3) Install safety chain (11) on angle (12) using pin (10) and new cotter pin (9). Repeat for remaining safety chain.

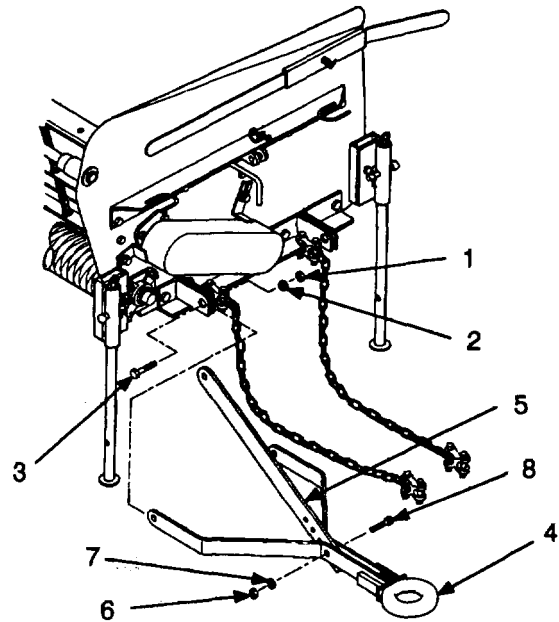

d. Assembly.

- (1) Install clevises (22) on each end of chain (11) using pin (21) and new cotter pin (20).
- (2) Install pin (24) and hair pin (23) on front clevises (22).
- (3) Repeat steps (1) and (2) for remaining safety chain.

e. Installation.

- (1) Install frame section (19) on spreader using four screws (18), new lockwashers (17), and

- (4) Install lift bar (5) on drawbar (4) using screw (8), new lockwasher (7), and nut (6). Tighten lift bar mounting screw to 120 lb-ft.
- (5) Install drawbar (4) and lift bar (5) on spreader using three screws (3), new lockwashers (2), and nuts (1). Tighten mounting screws to 120 lb-ft.

4-24. TRUCK HITCH REPLACEMENT.

Refer to paragraph 4-13 for instructions on removing and installing the truck hitch.

4-25. LEVELING LEG REPAIR.

This task covers:

a. Removal

b. Installation

INITIAL SETUP

Tools:

Tool Kit, General Mechanic's Automotive
12-ton hydraulic jack

Materials/Parts:

One lockwasher

Equipment Conditions:

References

Para 4-12 Transport truck installed on spreader.

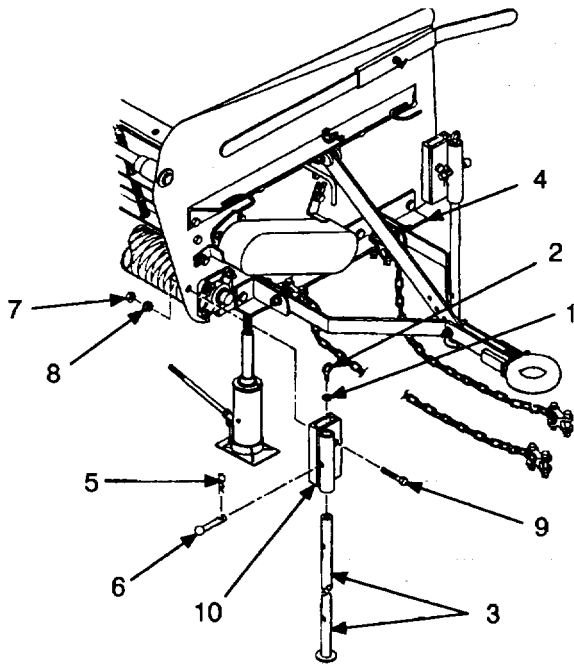

a. *Removal.*

NOTE

This procedure can be used for either leveling leg.

- (1) Loosen nut (1) and remove eyebolt (2) from top of leveling leg (3). Remove nut from eyebolt.

- (2) Place hydraulic jack under bottom angle (4). Jack up spreader enough to take weight off leveling leg (3)
- (3) Remove lock pin (5) and pin (6) from leveling leg (3). Jack up spreader enough to remove leveling leg.
- (4) Remove nut (7), lockwasher (8), screw (9), and bracket (10) from spreader. Discard lockwasher.

b. *Installation.*

- (1) Install bracket (10) on spreader using screw (9), new lockwasher (8), and nut (7).

WARNING

Install leveling leg in lowered position. If leveling leg is not lowered, spreader will fall over when hydraulic jack is removed. Failure to follow this warning could result in severe injury or equipment damage.

- (2) Slide leveling leg (3) into bracket (10). Secure leveling leg in lowered position with pin (6) and lock pin (5).
- (3) Screw nut (1) onto eyebolt (2).
- (4) Screw eyebolt (2) into top of leveling leg (3). Tighten nut (1) against leveling leg.
- (5) Lower and remove hydraulic jack.

4-26. REFLECTOR REPLACEMENT.

This task covers:

a. Removal

b. Installation

INITIAL SETUP

Tools:

Tool Kit, General Mechanic's Automotive

Materials/Parts:

Two lockwashers

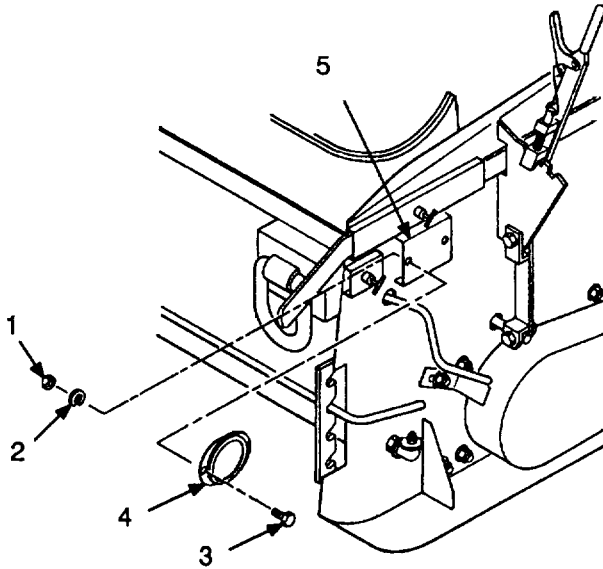

a. Removal. Remove two nuts (1), lockwashers (2), and screws (3) securing reflector (4) to bracket (5). Remove reflector. Discard lockwashers.

b. Installation. Install reflector (4) on bracket (5) using two screws (3), new lockwashers (2), and nuts (1).

4-27. TOOLBOX REPLACEMENT.

This task covers: a. Removal b. Installation

INITIAL SETUP

Tools:
Tool Kit, General Mechanic's Automotive

Materials/Parts:
Two lockwashers

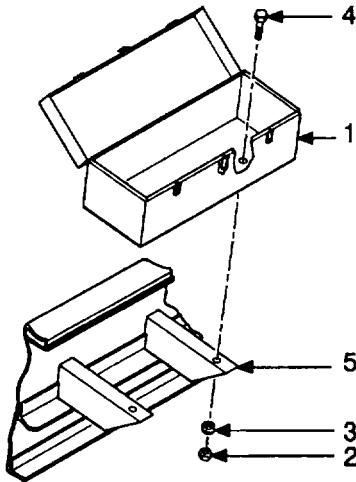

- a. *Removal.*
 - (1) Open toolbox (1) and remove contents.
 - (2) Remove two nuts (2), lockwashers (3), and screws (4) securing toolbox (1) to brackets (5). Remove toolbox. Discard lockwashers.
- b. *Installation.*
 - (1) Install toolbox (1) on brackets (5) using two screws (4), new lockwashers (3), and nuts (2).
 - (2) Return contents to toolbox (1) and close toolbox.

4-28. DATA PLATE REPLACEMENT.

This task covers: a. Removal b. Installation

INITIAL SETUP

Tools:
Tool Kit, General Mechanic's Automotive
Electric drill

Materials/Parts:
Four drive screws

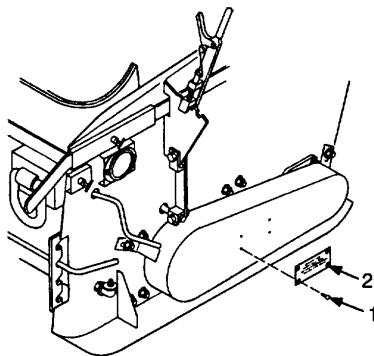

NOTE

This procedure can be used for any of the data plates. Feed roll chain cover caution plate is illustrated.

- a. *Removal.* Drill out four drive screws (1) and remove data plate (2).
- b. *Installation.* Install data plate (2) using four drive screws (1).

4-29. FEED ROLL CONTROL LEVER REPLACEMENT

This task covers:

a. Removal

b. Installation

INITIAL SETUP*Tools:*

Tool Kit, General Mechanic's Automotive

Materials/Parts:

Two locknuts

*Equipment Conditions:**References:*

Para 4-15 Spreader uncoupled from dump truck.

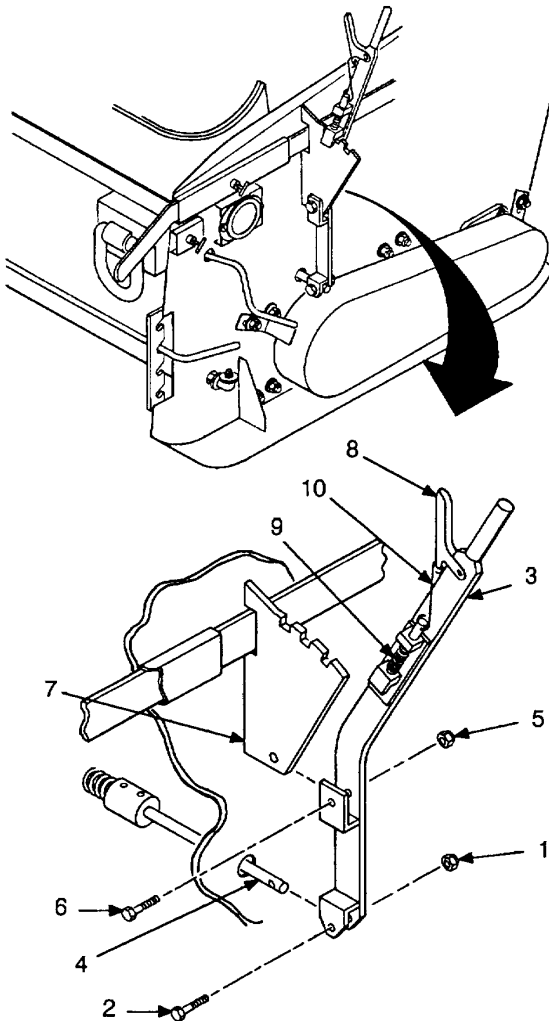
**a. Removal.**

- (1) Remove locknut (1) and screw (2) securing feed roll control lever (3) to shaft (4). Discard locknut.
- (2) Remove locknut (5) and screw (6) securing feed roll control lever (3) to quadrant (7). Discard locknut.
- (3) Squeeze grip (8) to release plunger assembly (9). Remove feed roll control lever (3) from spreader.

b. Installation.

- (1) Squeeze grip (8) to release plunger assembly (9). Position feed roll control lever (3) for installation.
- (2) Secure feed roll control lever (3) to quadrant (7) using screw (6) and new locknut (5).
- (3) Secure feed roll control lever (3) to shaft (4) using screw (2) and new locknut (1).
- (4) Check feed roll control lever (3) for proper operation. If feed roll control lever does not securely lock on quadrant (7), slightly unbend loop at one end of wire (10) to increase tension on plunger assembly (9).

4-30. CLUTCH SHIFT ARM REPAIR.

This task covers:

- | | |
|----------------|-----------------|
| a. Removal | c. Assembly |
| b. Disassembly | d. Installation |

INITIAL SETUP

Tools:

Tool Kit, General Mechanic's Automotive

Materials/Parts:

One lockwasher
Two locknuts

Equipment Conditions:

References:

Para 4-15 Spreader uncoupled from dump truck.

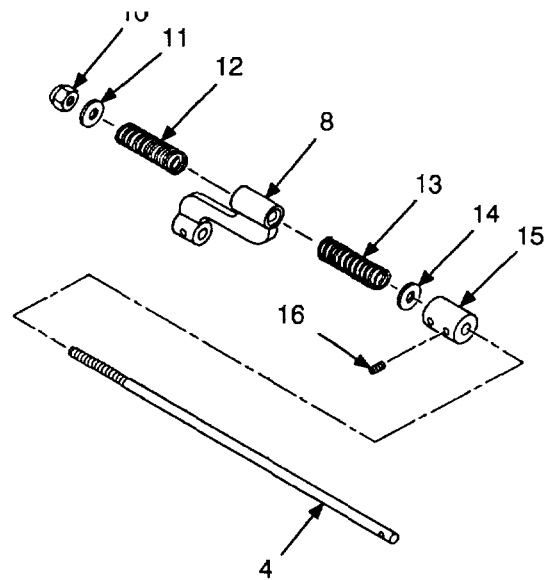
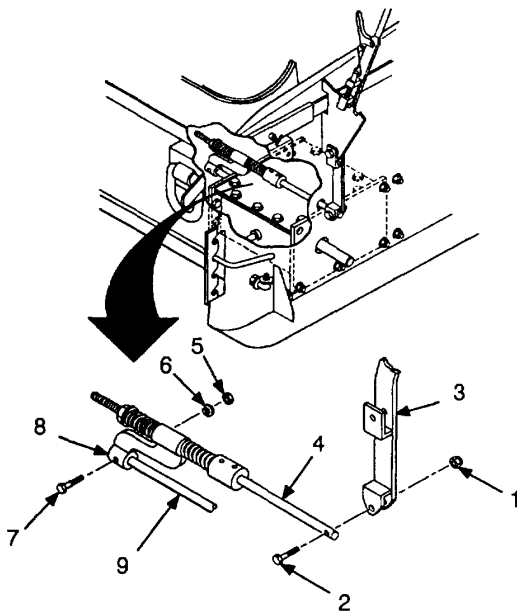

a. Removal

- (1) Remove locknut (1) and screw (2) securing feed roll control lever (3) to shaft (4). Discard locknut.
- (2) Remove nut (5), lockwasher (6), and screw (7) securing bracket (8) to throwout shaft (9). Discard lockwasher.
- (3) Slide shift arm toward center of spreader to disengage bracket (8) from throwout shaft (9). Remove shift arm from spreader.

b. Disassembly.

- (1) Measure and record position of locknut (10) on shaft (4). Locknut should be installed in same position.
- (2) Remove locknut (10), flatwasher (11), spring (12), bracket (8), spring (13), and flatwasher (14) from shaft (4). Discard locknut.
- (3) Measure and record position of collar (15) on shaft (4). Collar should be installed in same position.
- (4) Loosen two setscrews (16) and remove collar (15) from shaft (4).

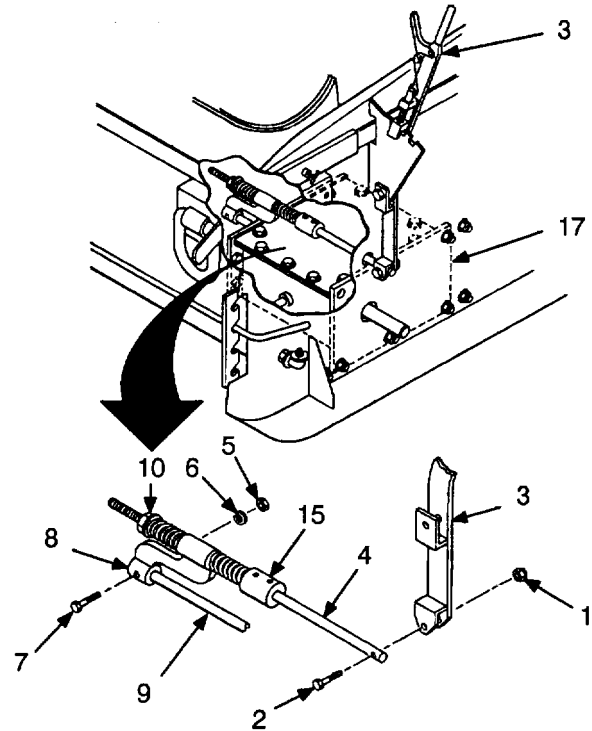
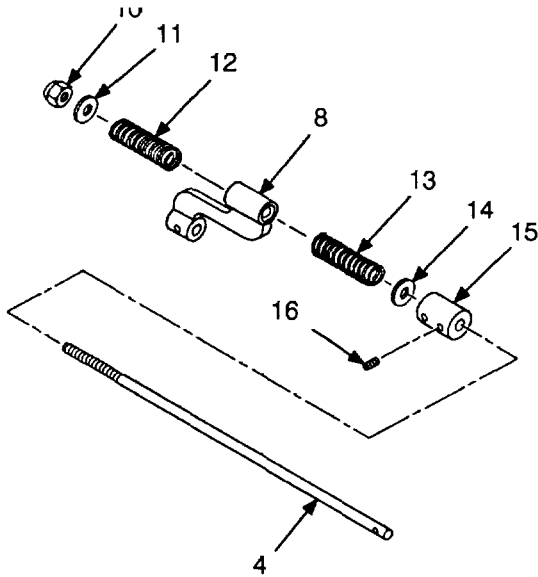

c. *Assembly.*

- (1) Slide collar (15) onto shaft (4) to position recorded in disassembly step (3). Tighten two setscrews (16)
- (2) Install flatwasher (14), spring (13), bracket (8), spring (12), flatwasher (11), and new locknut (10) on shaft (4). Tighten locknut to position recorded in disassembly step (1). that feed roll turns.

d. *Installation*

- (1) Working from center of spreader, slide shift arm into position. Ensure that bracket (8) engages throwout shaft (9).
- (2) Install screw (7), new lockwasher (6), and nut (5) to secure bracket (8) to throwout shaft (9).
- (3) Secure feed roll control lever (3) to shaft (4) using screw (2) and new locknut (1).
- (4) Set feed roll control lever (3) to FORWARD SPREAD. Rotate traction tires or pull spreader forward. Ensure that feed roll turns.

- (5) With feed roll control lever (3) set to FORWARD SPREAD, rotate traction tires in a reverse direction or push spreader backward. Gearbox should disengage and feed roll should stop turning.
- (6) Set feed roll control lever (3) to REVERSE SPREAD. Rotate traction tires in a reverse direction or push spreader backward. Ensure
- (7) With feed roll control lever (3) set to REVERSE SPREAD, rotate traction tires in a forward direction or pull spreader forward. Gearbox should disengage and feed roll should stop turning.
- (8) If any of the checks In steps (4) through (7) fail, adjust position of collar (15) and locknut (10) on shaft (4). If gearbox will not engage, increase tension on springs (12 and 13). If gearbox will not disengage, decrease tension on springs. Repeat steps (4) through (7) until clutch shift arm is properly adjusted. until clutch shift arm

4-31. GATE ADJUSTING LEVER AND RACK REPLACEMENT.

This task covers:

a. Removal

b. Installation

INITIAL SETUP

Tools:

Tool Kit, General Mechanic's Automotive

Materials/Parts:

Four lockwashers

Equipment Conditions:

References:

Para 4-15 Spreader uncoupled from dump truck.

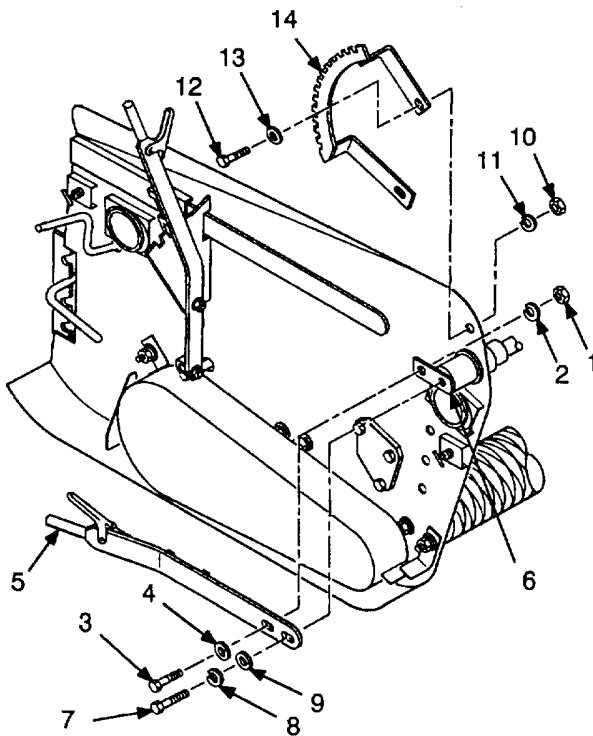

a. Removal.

- (1) Remove nut (1), lockwasher (2), screw (3), and flatwasher (4) securing gate adjusting lever (5) to bearing (6). Discard lockwasher.
- (2) Remove screw (7), lockwasher (8), and flatwasher (9) securing gate adjusting lever (5) to bearing (6). Remove gate adjusting lever.
- (3) Remove two nuts (10), lockwashers (11), screws (12), and flatwashers (13) securing

rack (14) to spreader. Remove rack. Discard lockwashers.

b. Installation.

- (1) Install rack (14) on spreader using two screws (12), flatwashers (13), new lockwashers (11), and nuts (10). Do not fully tighten nuts.
- (2) Install gate adjusting lever (5) on bearing (6) using screw (7), new lockwasher (8), and flatwasher (9).
- (3) Secure gate adjusting lever (5) to bearing (6) using screw (3), flatwasher (4), new lockwasher (2), and nut (1).
- (4) Adjust rack (14) until it is engaged by adjusting lever (5), then tighten nuts (10).

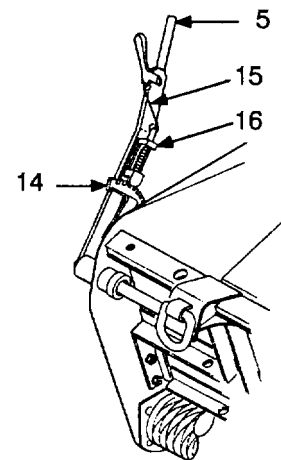

- (5) Check gate adjusting lever (5) for proper operation. If gate adjusting lever does not securely lock on rack (14), slightly unbend loop at one end of wire (15) to increase tension on plunger assembly (16).

4-32. GATE ADJUSTMENT SCREW REPLACEMENT.

This task covers: a. Removal b. Installation

INITIAL SETUP

Tools:

Tool Kit, General Mechanic's Automotive

Materials/Parts:

Two locknuts

Three cotter pins

Equipment Conditions:

References:

Para 2-1 Gate fully lowered.

Para 4-15 Spreader uncoupled from dump truck.

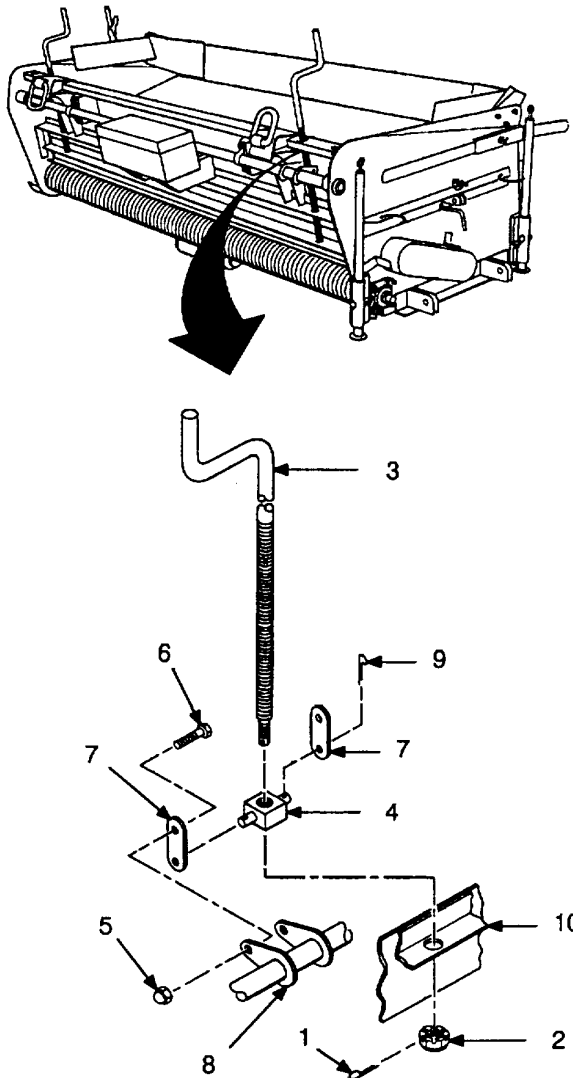

a. *Removal.*

NOTE

The following procedure is for one gate adjustment screw. Repeat for second gate adjustment screw if necessary.

- (1) Remove cotter pin (1) and nut (2) from adjustment screw (3). It may be necessary to turn screw to remove nut. Discard cotter pin.
- (2) Unscrew and remove adjustment screw (3) from nut (4).
- (3) Remove locknut (5) and screw (6) securing yoke (7) to shaft (8). Discard locknut.
- (4) Repeat step (3) for second yoke. Remove two yokes (7) and nut (4) from shaft (8).
- (5) Remove two cotter pins (9) and yokes (7) from nut (4). Discard cotter pins.

b. *Installation.*

- (1) Install yoke (7) on nut (4) and secure with new cotter pin (9). Repeat for second yoke.

NOTE

- Screws must be installed on inside with locknuts on outside to prevent interference with adjustment screw.
- Do not fully tighten locknuts. Yokes must be free to pivot.

- (2) Install yoke (7) on shaft (8) using screw (6) and new locknut (5). Repeat for second yoke.
- (3) Screw adjustment screw (3) into nut (4) and through gate (10). Secure adjustment screw using nut (2) and new cotter pin (1).

4-33. GATE ADJUSTING SHAFT AND BEARINGS REPLACEMENT.

This task covers:

a. Removal

b. Installation

INITIAL SETUP

Tools:

Tool Kit, General Mechanic's Automotive

Materials/Parts:

Five lockwashers

Equipment Conditions:

Reference

- Para 4-15 Spreader uncoupled from dump truck.
- Para 4-31 Gate adjusting lever removed.
- Para 4-32 Gate adjustment screws removed.
- Para 4-27 Toolbox removed.

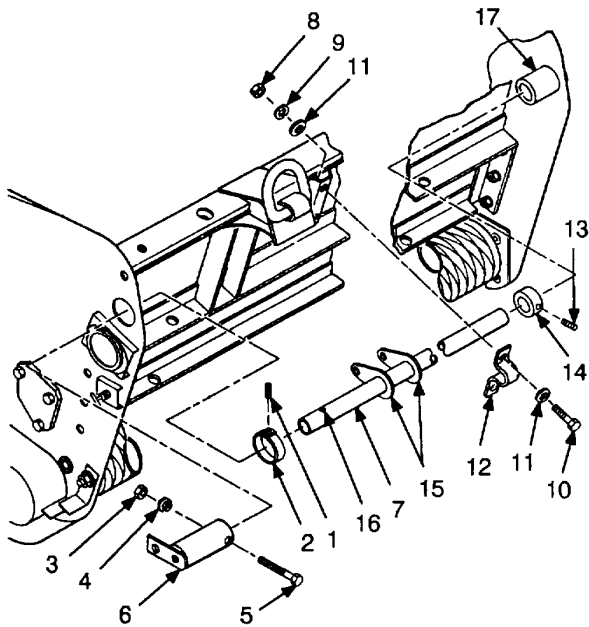

a. Removal.

- (1) Loosen setscrew (1) in collar (2).
- (2) Remove nut (3), lockwasher (4), and screw (5) securing bearing (6) to adjusting shaft (7). Remove bearing. Discard lockwasher.
- (3) Remove two nuts (8), lockwashers (9), screws (10), and four flatwashers (11) securing each bearing (12) to spreader. Remove two bearings. Discard lockwashers.

- (4) Loosen setscrew (13) in collar (14).
- (5) Slide adjusting shaft (7) to either side to free it from spreader. Remove adjusting shaft from spreader.
- (6) Remove two collars (2 and 14) from adjusting shaft (7).

b. Installation.

- (1) Slide two collars (2 and 14) onto adjusting shaft (7).
- (2) Position adjusting shaft (7) for installation. Ensure that screw arms (15) point forward and screw hole (16) for bearing (6) is on left side.
- (3) Install each bearing (12) using two screws (10), four flatwashers (11), two new lockwashers (9), and two nuts (8).
- (4) Slide collar (14) against bearing (17) and tighten setscrew (13).
- (5) Install bearing (6) on adjusting shaft (7) using screw (5), new lockwasher (4), and nut (3).
- (6) Slide collar (2) against bearing (6) and tighten setscrew (1).

FOLLOW-ON MAINTENANCE:

- Install gate adjustment screws (para 4-32).
- Install gate adjusting lever (para 4-31).
- Install toolbox (para 4-27).
- Lubricate bearings (Chapter 3, Section I).

4-34. BELTING REPLACEMENT.

This task covers:

a. Removal

b. Installation

INITIAL SETUP

Tools:

Tool Kit, General Mechanic's Automotive

Materials/Parts:

Thirty-two lockwashers

Equipment Conditions:

Reference:

Para 4-15 Spreader uncoupled from dump truck.

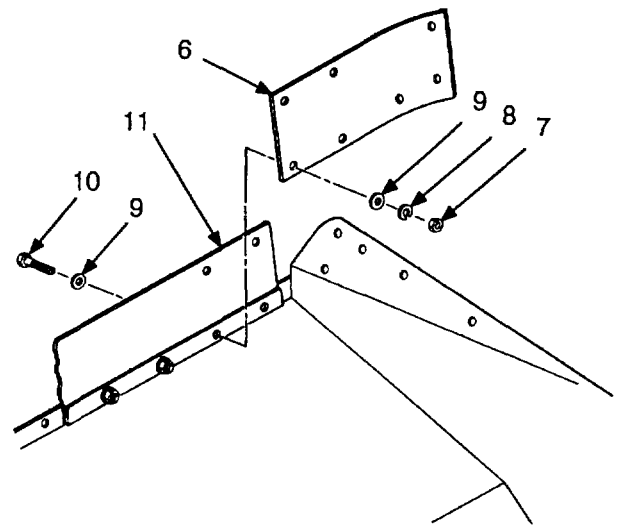
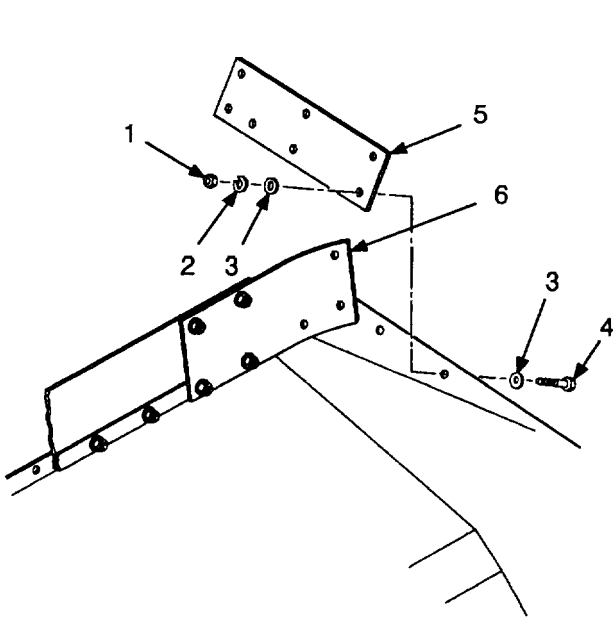

a. *Removal*

(1) Remove five nuts (1), lockwashers (2), ten flatwashers (3), and five screws (4) securing cover (5) to corner belting (6) and side of hopper. Remove side cover. Discard lockwashers.

(2) Remove five nuts (7), lockwashers (8), ten flatwashers (9), and five screws (10) securing corner belting (6) to front of hopper and center belting (11). Remove corner belting. Discard lockwashers.

(3) Repeat steps (1) and (2) on opposite side of spreader.

4-34. BELTING REPLACEMENT (CONT).

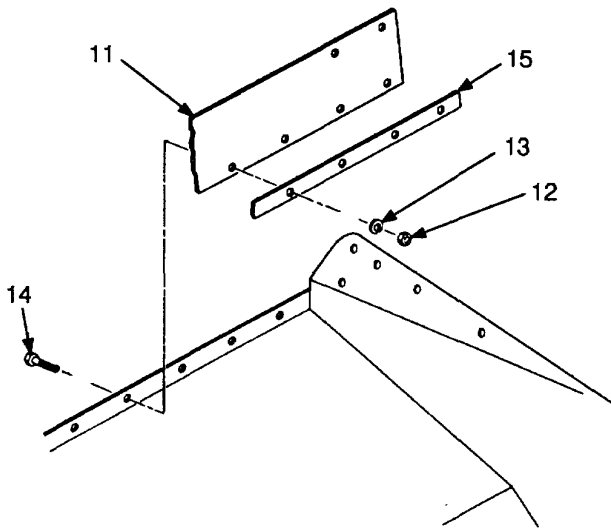

- (4) Remove 12 nuts (12), lockwashers (13), and screws (14) securing center belting (11) and reinforcement (15) to hopper. Remove center belting and reinforcement from hopper. Discard lockwashers.

b. *Installation.*

- (1) Install center belting (11) and reinforcement (15) on front of hopper using 12 1-14 in. screws (14), new lockwashers (13), and nuts (12).

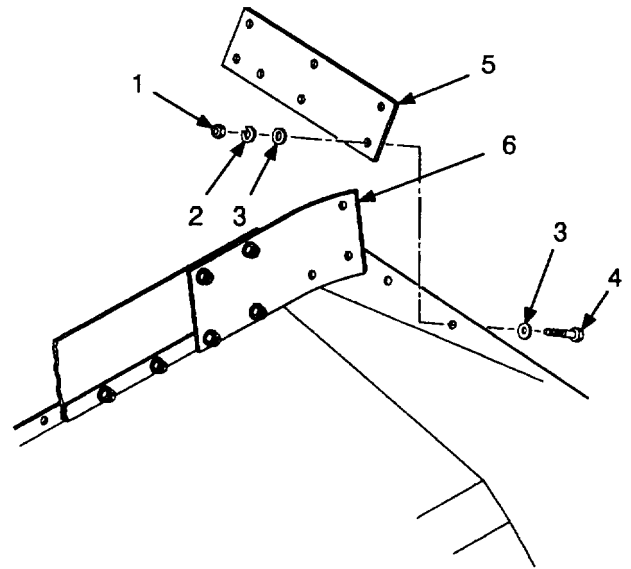

- (3) Install side cover (5) on side of hopper and corner belting (6) using five screws (4), ten flatwashers (3), five new lockwashers (2), and nuts (1). Use 1-4 in. screws through side of hopper where side cover and corner belting overlap. Use 1-4 in. screw in other three holes.
- (4) Repeat steps (2) and (3) on opposite side of spreader.

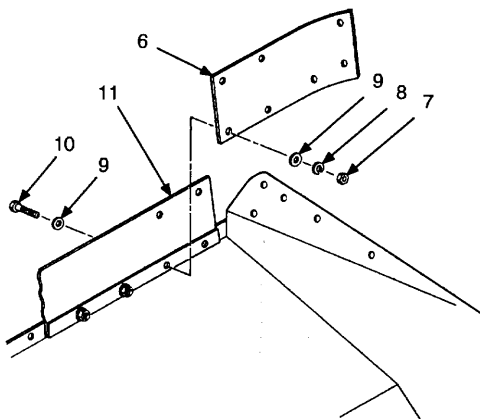

- (2) Install corner belting (6) on side of hopper and center belting (11) using five screws (10), ten flatwashers (9), five new lockwashers (8), and nuts (7). Use 1-X in. screws where corner belting overlaps reinforcement (15). Use 1-4 in. screws in other three holes.

4-35. BALANCING HANDLE REPLACEMENT.

This task covers:

a. Removal

b. Installation

INITIAL SETUP

Tools:

Tool Kit, General Mechanic's Automotive

Materials/Parts:

Two spring pins

Equipment Conditions:

Reference:

Para 4-15 Spreader uncoupled from dump truck.

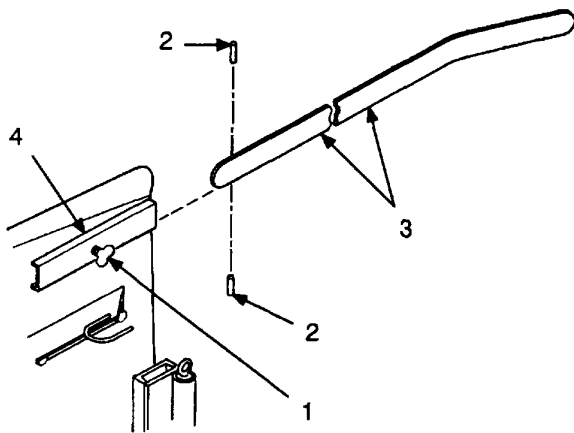
a. *Removal.***NOTE**

The following procedure is for one balancing handle. Repeat for second balancing handle if necessary.

- (1) Loosen thumbscrew (1).
- (2) Remove two spring pins (2) from handle (3). Pull handle out of bracket (4) and remove. Discard spring pins.

b. *Installation.*

- (1) Slide handle (3) into bracket (4) and secure with two new spring pins (2).
- (2) Tighten thumbscrew (1).

4-36. GATE AND BRACKETS REPLACEMENT.

This task covers: a. Removal b. Installation

INITIAL SETUP

Tools:

- Tool Kit, General Mechanic's Automotive
- Torque wrench

Materials/Parts:

- Two cotter pins
- Six lockwashers

Equipment Conditions:

Reference:

- Para 4-15 Spreader uncoupled from dump truck.
- Para 4-12 Transport truck removed.
- Para 2-1 Gate fully lowered.

Personnel Required: Two

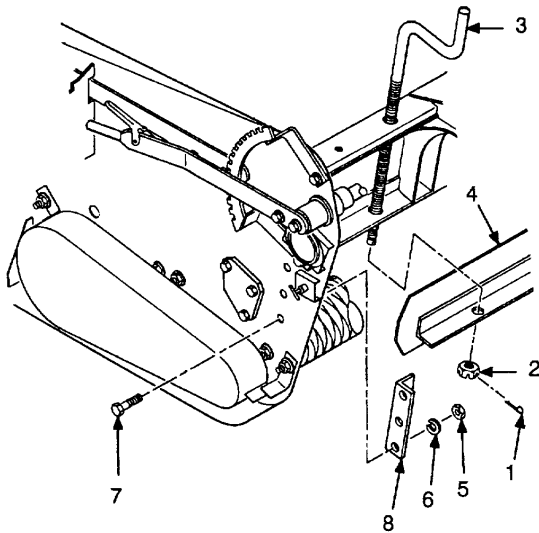

a. Removal.

- (1) Remove cotter pin (1) and nut (2) from each adjustment screw (3). Raise screws enough F to clear gate (4). Discard cotter pins.

WARNING

- Gate is heavy (approx 71 lb) and awkward to handle. Use assistance when removing gate. to follow this warning could cause injury.
 - Gate will fall off spreader when brackets are removed. Support gate in position before continuing. Failure to follow this warning could cause injury.
- (2) Remove three nuts (5), lockwashers (6), and screws (7) securing each bracket (8) to sides of hopper. Remove two brackets and gate (4). Discard lockwashers.

b. Installation.

WARNING

- Gate is heavy (approx 71 lb) and awkward to handle. Use assistance when installing gate. to follow this warning could cause injury.
- Gate will be unsupported until nuts are installed on adjustment screws. Block gate in position to prevent it from falling and keep fingers away from gate. Failure to follow this warning could cause injury.

- (1) Lower adjustment screws (3) and position gate (4) on adjustment screws. Install nut (2) on each adjustment screw.
- (2) Install each bracket (8) using three screws (7), new lockwashers (6), and nuts (5). Tighten bracket mounting bolts to 60 lb-ft.
- (3) Secure nut (2) to each adjustment screw (3) using new cotter pin (1).

FOLLOW-ON MAINTENANCE:

- Install transport truck (para 4-12).

4-37. GEARBOX REPLACEMENT.

This task covers:

a. Removal

b. Installation

INITIAL SETUP

Tools:

Tool Kit, General Mechanic's Automotive Shop Equipment, Automotive Maintenance and Repair, Organizational Maintenance, Common No 1

Lifting device with 125 lb capacity

Lifting slings or chains

1 gal. drain pan

Materials/Parts:

Twenty-seven lockwashers

Equipment Conditions:

References

Para 4-15 Spreader uncoupled from dump truck.

Para 4-39 Feed roll drive chain and sprocket removed.

Personnel Required: Two

a. *Removal.*

NOTE

Use drain pan to catch draining gear oil. Clean up all spills. Dispose of oil in accordance with local and environmental policies.

- (1) Remove drain plug (1) from gearbox (2). Allow all oil to drain, then reinstall drain plug.
- (2) Remove nut (3), lockwasher (4), and screw (5) securing shift arm bracket (6) to throwout shaft (7). Set feed roll control lever to REVERSE SPREAD to disengage shift arm bracket from throwout shaft.
- (3) Remove pipe plug (8) from elbow (9).
- (4) Remove elbow (9) from nipple (10).
- (5) Remove nipple (10) from elbow (11).
- (6) Remove elbow (11) from nipple (12).
- (7) Remove nipple (12) from gearbox (2).
- (8) Remove traction drive wheels from gearbox side of spreader (para 4-41).

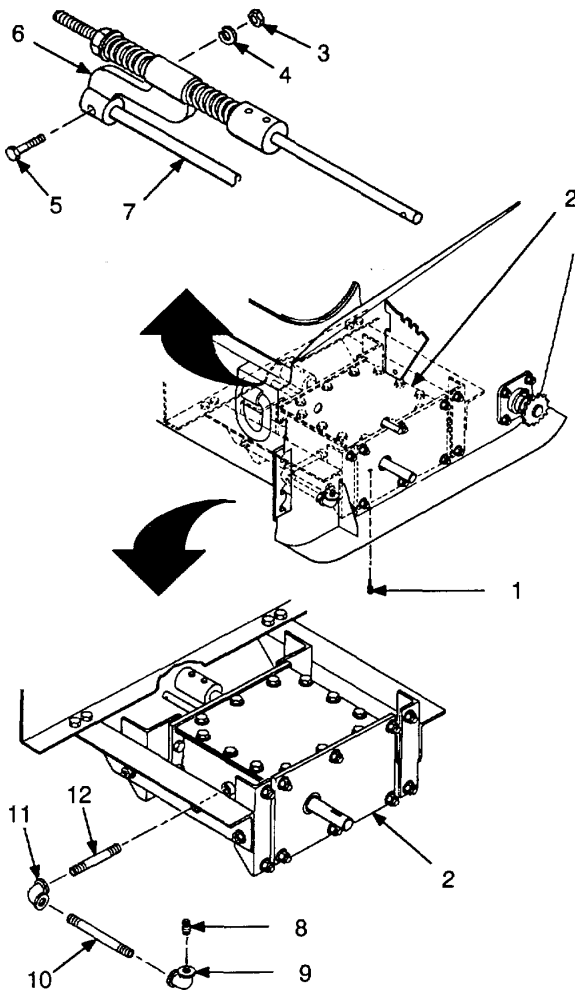

4-37. GEARBOX REPLACEMENT (CONT).

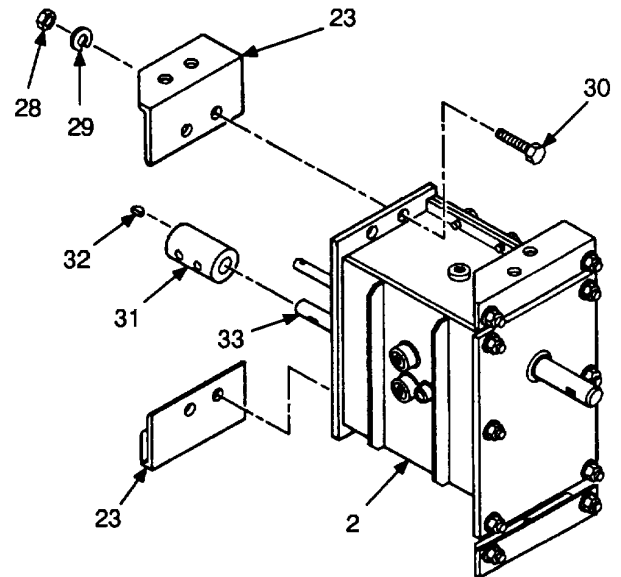
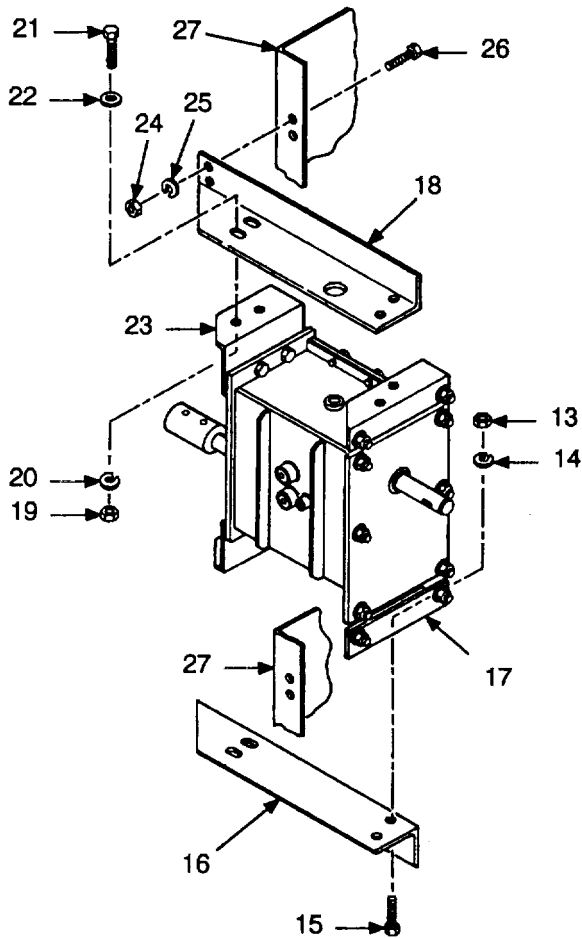

- (9) Remove two nuts (13), lockwashers (14), and screws (15) securing rear angle (16) to outside angle (17). Repeat for front angle (18). Discard lockwashers
- (10) Remove two nuts (19), lockwashers (20), screws (21), and flatwashers (22) securing front angle (18) to inside angle (23). Repeat for rear angle (16). Discard lockwashers.
- (11) Remove two nuts (24), lockwashers (25), and screws (26) securing front angle (18) to wheel bearing support (27). Remove front angle. Repeat for rear angle (16). Discard lockwashers.

- (12) Remove two nuts (28), lockwashers (29), and screws (30) securing each inside angle (23) to gearbox (2). Remove angles. Discard lockwashers.
- (13) Remove clutch (31) and key (32) from drive shaft (33).

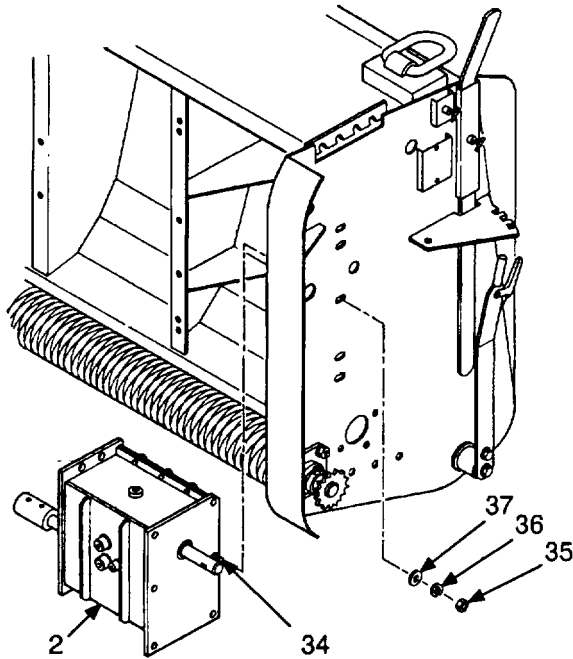

WARNING

Keep clear of equipment when it is being raised and lowered. Do not allow heavy components to swing while suspended by a lifting device. Exercise extreme caution when working near a cable under tension. Failure to follow this warning may result in severe injury or death to personnel.

NOTE

Upper, middle gearbox mounting screw (34) cannot be removed unless gearbox cover mounting screw is removed.

- (14) Wrap lifting slings or chains around gearbox (2). Using a suitable lifting device, support gearbox (125 lb) in position.
- (15) Remove six nuts (35), lockwashers (36), flatwashers (37), and five screws (34) securing gearbox (2) to spreader. Using a suitable lifting device, remove gearbox. Discard lockwashers. Remove lifting slings or chains from gearbox.

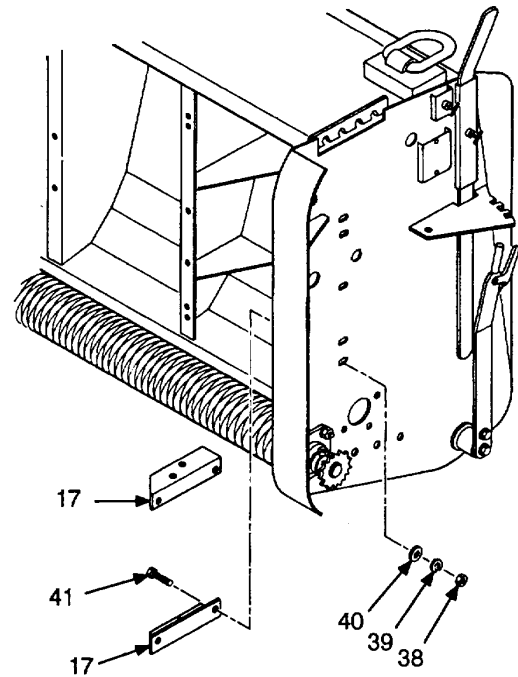

- (16) Remove two nuts (38), lockwashers (39), flatwashers (40), and screws (41) securing each outside angle (17) to spreader. Remove angles. Discard lockwashers.

b. Installation.

NOTE

Do not fully tighten any mounting hardware until instructed to do so. There should be enough play in all brackets so that gearbox can be installed with- out difficulty.

- (1) Install each outside angle (17) on spreader using two screws (41), flatwashers (40), new lockwashers (39), and nuts (38).

14-37. GEARBOX REPLACEMENT (CONT).

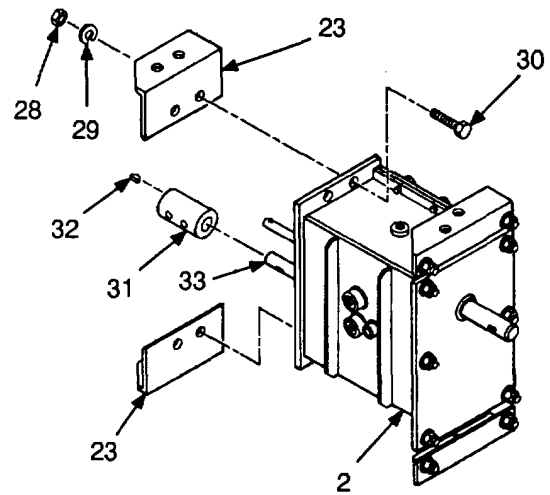
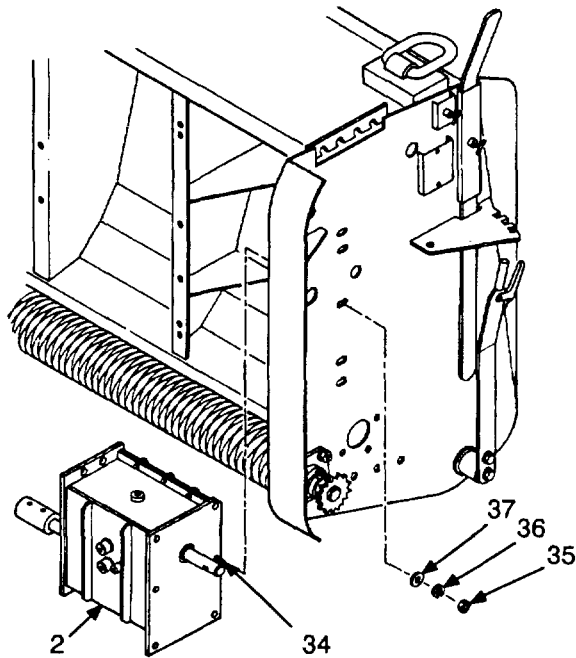

WARNING
 Keep clear of equipment when it is being raised and lowered.: Do not allow heavy components to swing while suspended by a lifting device. Exercise extreme caution when working near a cable under tension. Failure to follow this warning may result in severe injury or death to personnel.

- (2) Wrap lifting slings or chains around gearbox (2). Using a suitable lifting device, raise gearbox (125 lb) and position for installation.
- (3) Install gearbox (2) on spreader using six screws (34), flatwashers (37), new lockwashers (36), and nuts (35). Remove lifting slings or chains from gearbox.

- (4) Install key (32) and clutch (31) on drive shaft (33).
- (5) Install each inside angle (23) on gearbox (2) using two screws (30), new lockwashers (29), and nuts (28).

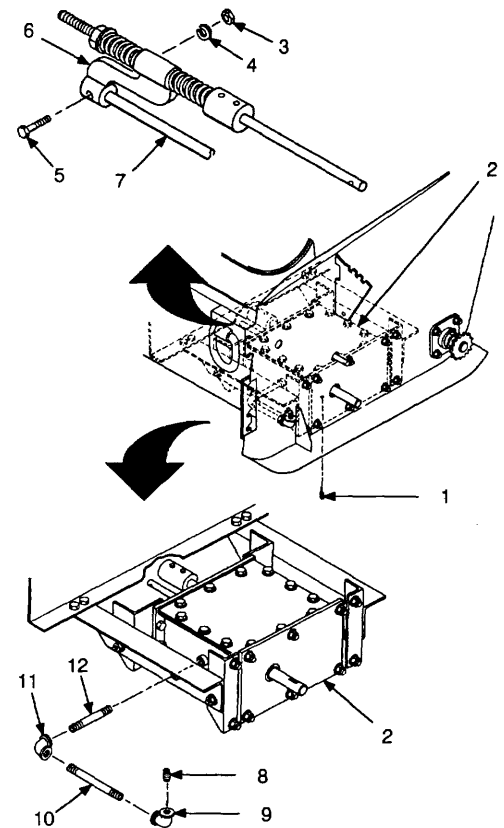
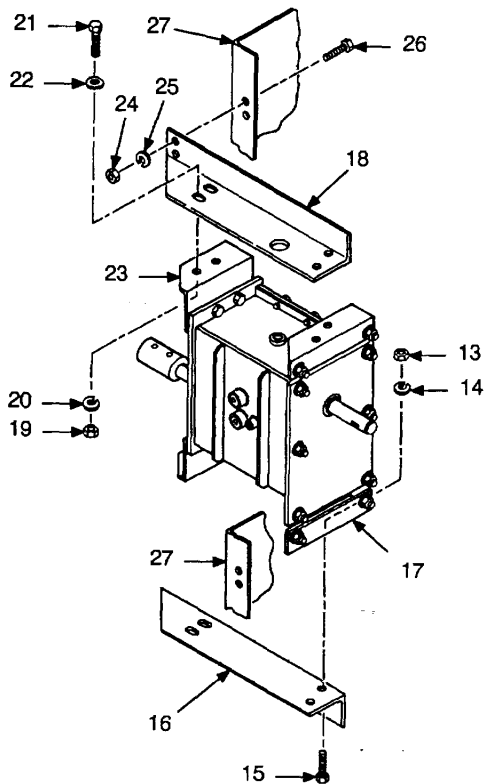

- (6) Install front angle (18) on wheel bearing support (27) using two screws (26), new lockwashers (25), and nuts (24). Repeat for rear angle (16).
- (7) Secure rear angle (16) to outside angle (17) using two screws (15), new lockwashers (14), and nuts (13). Repeat for front angle (18).
- (8) Secure front angle (18) to inside angle (23) using two screws (21), flatwashers (22), new lockwashers (20), and nuts (19). Repeat for rear angle (16).

- (9) Fully tighten all gearbox mounting hardware to 60 lb-ft.
- (10) Fully tighten all bracket mounting hardware to 60 lb-ft.
- (11) Secure bracket (6) to throwout shaft (7) using screw (5), new lockwasher (4), and nut (3).
- (12) Install nipple (12) in gearbox (2).
- (13) Install elbow (11) on nipple (12).
- (14) Install nipple (10) in elbow (11).
- (15) Install elbow (9) on nipple (10).
- (16) Install pipe plug (8) in elbow (9).

FOLLOW-ON MAINTENANCE:

- Install traction drive wheels (para 4-41).
- Install feed roll drive chain and sprocket (para 4-39).
- Lubricate gearbox (Chapter 3, Section I).

14-38. AGITATOR DRIVE CHAIN REPLACEMENT.

This task covers: a. Removal b. Installation

INITIAL SETUP*Tools:*

Tool Kit, General Mechanic's Automotive

Materials/Parts:

GAA (Item 3, Appendix E)

Two lockwashers

*Equipment Conditions:**References*

Para 4-15 Spreader uncoupled from dump truck.

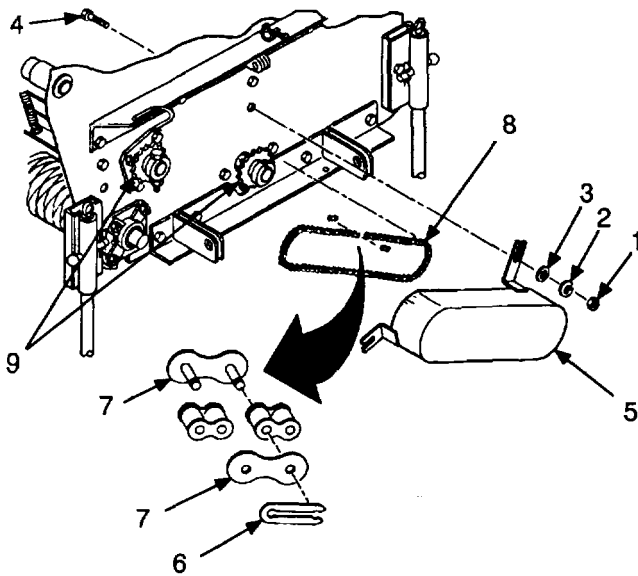
*a. Removal.*

- (1) Remove two nuts (1), lockwashers (2), flatwashers (3), and screws (4) securing chain cover (5) to spreader. Remove chain cover. Discard lockwashers.
- (2) Remove clip (6) from connecting link (7). Separate connecting link and remove chain (8) from sprockets (9).

b. Installation.

- (1) Install chain (8) around sprockets (9) and secure with connecting link (7). Install clip (6).
- (2) Lubricate chain (8) with GAA.
- (3) Install chain cover (5) on spreader using two screws (4), flatwashers (3), new lockwashers (2), and nuts (1).

4-39. FEED ROLL DRIVE CHAIN AND SPROCKET REPLACEMENT.

This task covers: a Removal b Installation

INITIAL SETUP

Tools:

Tool Kit, General Mechanic's Automotive

Equipment Conditions:

References

Para 4-15 Spreader uncoupled from dump truck.

Materials/Parts:

GAA (Item 3, Appendix E)

Two lockwashers

One connecting link

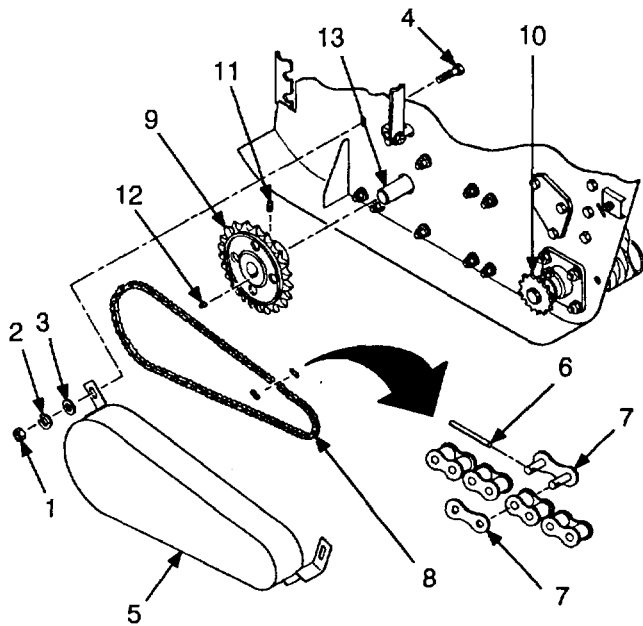

a. Removal.

- (1) Remove two nuts (1), lockwashers (2), flatwashers (3), and screws (4) securing chain cover (5) to spreader. Remove chain cover. Discard lockwashers.
- (2) Remove wire (6) from connecting link (7). Separate connecting link and remove chain (8) from sprockets (9 and 10). Discard connecting link.
- (3) Loosen two setscrews (11) in sprocket (9). Remove sprocket and key (12) from drive shaft (13).

b. Installation.

- (1) Install key (12) and sprocket (9) on drive shaft (13). Tighten two setscrews (11).
- (2) Install chain (8) around sprockets (9 and 10) and secure with new connecting link (7). Install wire (6), then bend ends of wire to secure connecting link.
- (3) Lubricate chain (8) with GAA.
- (4) Install chain cover (5) on spreader using two screws (4), flatwashers (3), new lockwashers (2), and nuts (1).

4-40. BALANCE ROLLER REPAIR.

- This task covers:
- | | | | |
|----|-------------------------|----|--------------|
| a. | Removal | d. | Assembly |
| b. | Disassembly | e. | Installation |
| c. | Cleaning and Inspection | | |

INITIAL SETUP

Tools:
 Tool Kit, General Mechanic's Automotive
 Torque wrench

Personnel Required: Two
Equipment Conditions:

Materials/Parts:
 Dry cleaning solvent (Item 11, Appendix E)
 Twelve lockwashers

References
 Para 4-15 Spreader uncoupled from dump truck.

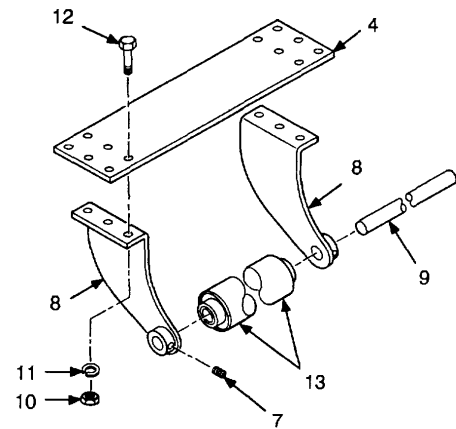
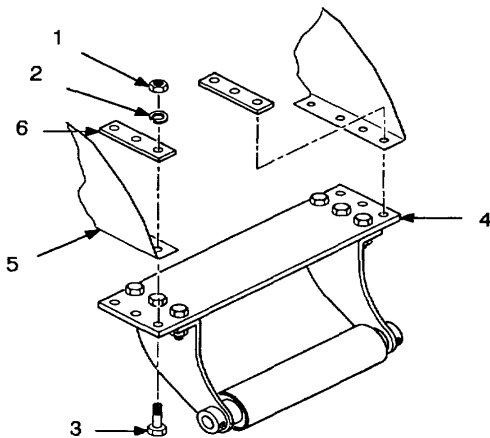

WARNING

Balance roller weighs 50 lb. If needed, use assistance when removing balance roller. Failure to follow this warning could cause injury.

a. *Removal.* Remove six nuts (1), lockwashers (2), and screws (3) securing balance roller mounting plate (4) to wheel bearing supports (5). Remove balance roller and two brackets (6). Discard lockwashers.

b. *Disassembly.*

- (1) Remove setscrew (7) from each mounting bracket (8). Drive shaft (9) out of mounting brackets.
- (2) Remove three nuts (10), lockwashers (11), and screws (12) securing each mounting bracket (8) to mounting plate (4). Remove mounting brackets from mounting plate and remove roller (13) from mounting brackets. Discard lockwashers.

c. *Cleaning and Inspection.*

WARNING

Dry cleaning solvent P-D-680 is toxic and flammable. Wear protective goggles, face mask, and gloves and use in a well ventilated area. Avoid contact with skin, eyes, and clothes and do not breath vapors. Do not use near open flame or excessive heat. The flash point for Type I solvent is 100 degrees F (38 degrees C). The flash point for Type II solvent is 140 degrees F (60 degrees C). If you become dizzy while using cleaning solvent, get fresh air immediately and get medical aid. If contact with eyes is made, wash your eyes with water and get medical aid immediately.

(1) Clean all parts with dry cleaning solvent and dry thoroughly.

(2) Inspect all parts for cracks, breaks, or other damage. Replace all damaged parts.

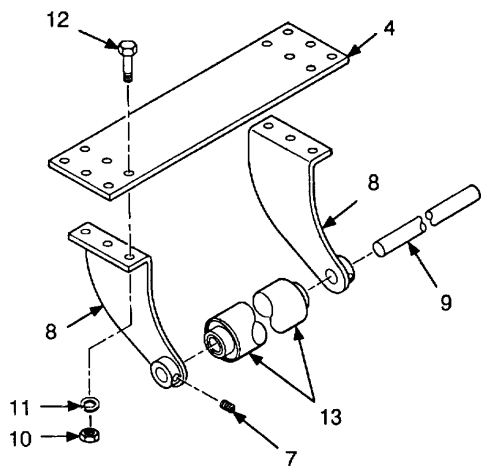

d. *Assembly.*

(1) Install one mounting bracket (8) on mounting plate (4) using three screws (12), new lockwashers (11), and nuts (10). Tighten bracket mounting screws to 120 lb-ft.

- (2) Position roller (13) on Installed mounting bracket (8). Install second mounting bracket on mounting plate (4) using three screws, new lockwashers, and nuts. Tighten bracket mounting screws to 120 lb-ft.
- (3) Install shaft (9) through mounting brackets (8) and roller (13). Secure each end of shaft using setscrew (7).

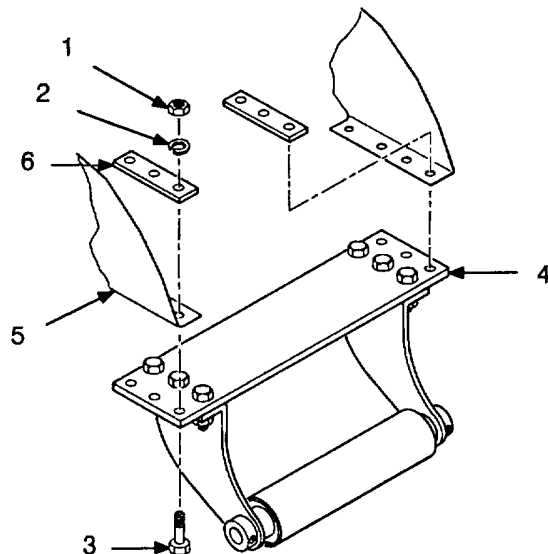

WARNING

Balance roller weighs 50 lb. If needed, use assistance when installing balance roller. Failure to follow this warning could cause injury.

e. *Installation.* Install two brackets (6) and balance roller mounting plate (4) on wheel bearing supports (5) using six screws (3), new lockwashers (2), and nuts (1). Tighten balance roller mounting screws to 120 lb-ft.

4-41. TRACTION WHEEL ASSEMBLY REPAIR.

- This task covers:
- | | | | |
|----|-------------------------|----|--------------|
| a. | Removal | d. | Assembly |
| b. | Disassembly | e. | Installation |
| c. | Cleaning and Inspection | | |

INITIAL SETUP

Tools:

- Tool Kit, General Mechanic's Automotive
- Lifting device with 2000 lb capacity
- Lifting slings or chains
- Blocking material
- Torque wrench

Materials/Parts:

- Dry cleaning solvent item 10, Appendix E)
- GAA (Item 3, Appendix E)

Twenty lockwashers

References:

- TM 9-214
- TM 9-2610-200-14

Equipment Conditions:

References

- | | |
|-----------|--|
| Para 4-15 | Spreader uncoupled from dump truck. |
| Para 2-1 | Agitator clutch disengaged. |
| Para 2-1 | Feed roll control lever set to NEUTRAL. |
| Para 4-14 | Operator's platform removed from spreader. |
| Para 4-12 | Transport truck and tongue removed |
| Para 4-27 | Toolbox removed. |
| Para 4-27 | Toolbox removed. |

Personnel Required: Three

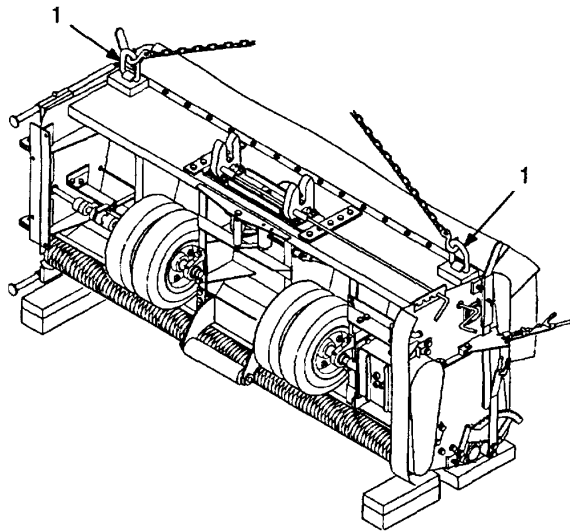

a. Removal.

NOTE

The following procedure can be used for either set of traction drive wheels. Differences between the two sides are noted in the procedure.

- (1) Connect lifting slings or chains to D-rings (1) at front of hopper.

WARNING

Do not allow heavy components to swing while suspended by a lifting device. Exercise extreme caution when working near a cable under tension. Failure to follow this warning may result in severe injury to personnel.

NOTE

Two people should balance spreader while the third person operates lifting device.

- (2) Using a suitable lifting device, slowly lift spreader (2000 lb) until it is suspended from D-rings (1) at front of hopper.
- (3) Place blocking under spreader. Slowly lower spreader onto blocking. Ensure that spreader is secure and stable before removing lifting device.

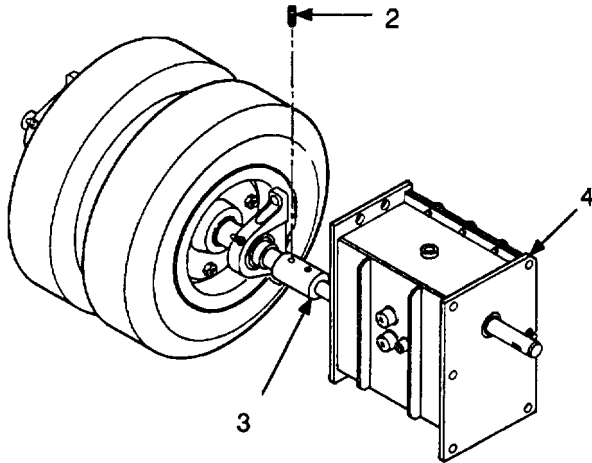

NOTE

Step (4) is for gearbox side of spreader only.

- (4) Loosen setscrew (2) in clutch (3). Slide clutch toward gearbox (4).

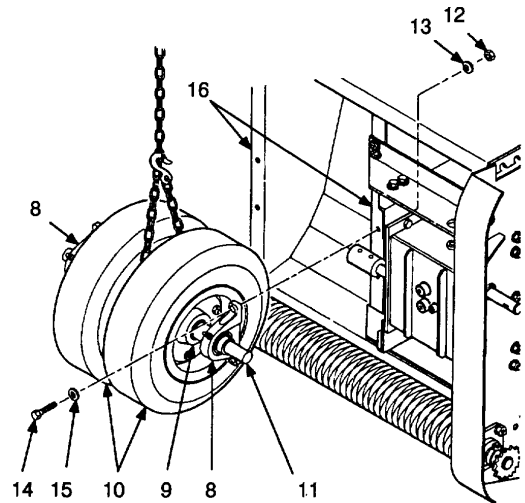

- (6) Loosen two setscrews in each bearing (8).
- (7) Loosen setscrew in each hub (9).
- (8) Slide tires (10) toward outside of spreader.
- (9) Tighten setscrew in each hub (9).
- (10) Slide tires (10) toward center of hopper to free shaft (11) from gearbox clutch or agitator clutch bearing.
- (11) Check clearance at outer end of shaft (11). If clearance is not sufficient to allow traction wheels to be removed, repeat steps (7) through (10).
- (12) Wrap lifting sling or chain around shaft (11) in between tires (10). Connect lifting sling or chain to lifting device and take up slack.
- (13) Remove two nuts (12), lockwashers (13), screws (14), and flatwashers (15) securing each bearing (8) to bearing supports (16).
- (14) Using lifting device, remove shaft (11) and tires (10) from spreader and rest on ground. Remove lifting slings or chains from shaft.

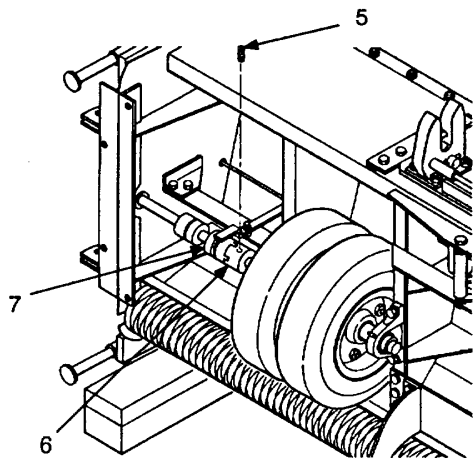

NOTE

Step (5) is for agitator control clutch side of spreader only.

- (5) Loosen setscrew (5) in bearing (6). Slide bearing toward clutch (7).

14-41. TRACTION WHEEL ASSEMBLY REPAIR (CONT)

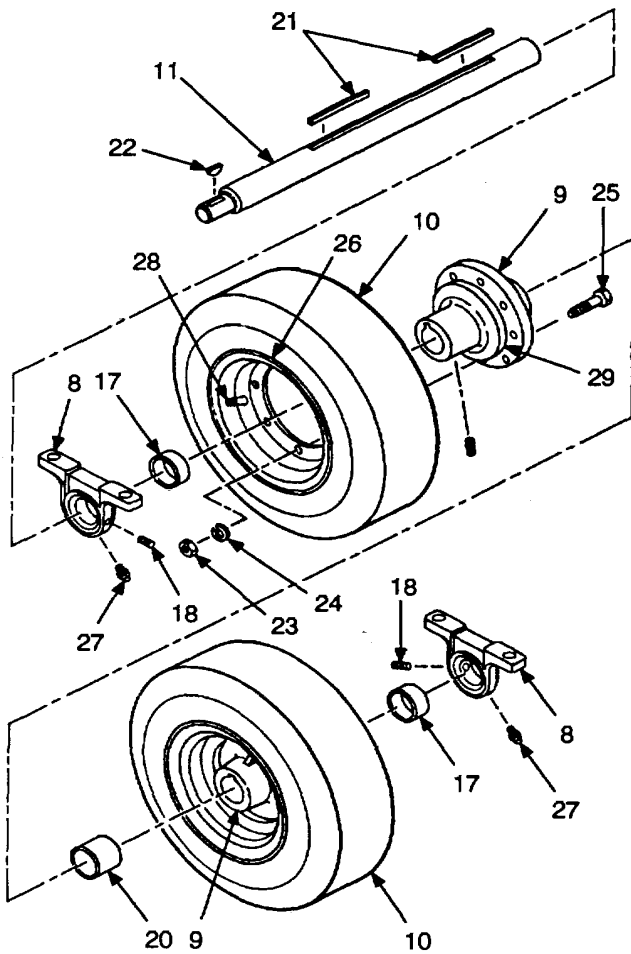

b. Disassembly.

- (1) Remove bearing (8) and spacer (17) from each end of shaft (11). If necessary, remove two setscrews (18) from each bearing.
- (2) Loosen setscrew (19) in each hub (9).

- (3) Remove shaft (11) from two hubs (9). Spacer (20) will come off with shaft.
- (4) Remove two keys (21) and woodruff key (22) from shaft (11).
- (5) Deflate tire. Remove eight nuts (23), lockwashers (24), and screws (25) securing hub (9) to rims (26). Remove hub. Discard lockwashers. Repeat for other wheel.
- (6) Remove lubrication fitting (27) from each bearing (8).

c. Cleaning and Inspection.

WARNING

Dry cleaning solvent P-D-680 is toxic and flammable. Wear protective goggles, face mask, and gloves and use in a well ventilated area. Avoid contact with skin, eyes, and clothes and do not breath vapors. Do not use near open flame or excessive heat. The flash point for Type I solvent is 100 degrees F (38 degrees C). The flash point for Type II solvent is 140 degrees F (60 degrees C). If you become dizzy while using cleaning solvent, get fresh air Immediately and get medical aid. If contact with eyes is made, wash your eyes with water and get medical aid immediately.

- (1) Clean all metal parts with dry cleaning solvent and dry thoroughly.
- (2) Inspect all parts for cracks, damage, or other defects. Replace all cracked, damaged, or defective parts.
- (3) Refer to TM 9-214 for bearing cleaning and inspection procedures.
- (4) Refer to TM 9-2610-200-14 for tire Inspection, disassembly, repair, and assembly procedures.

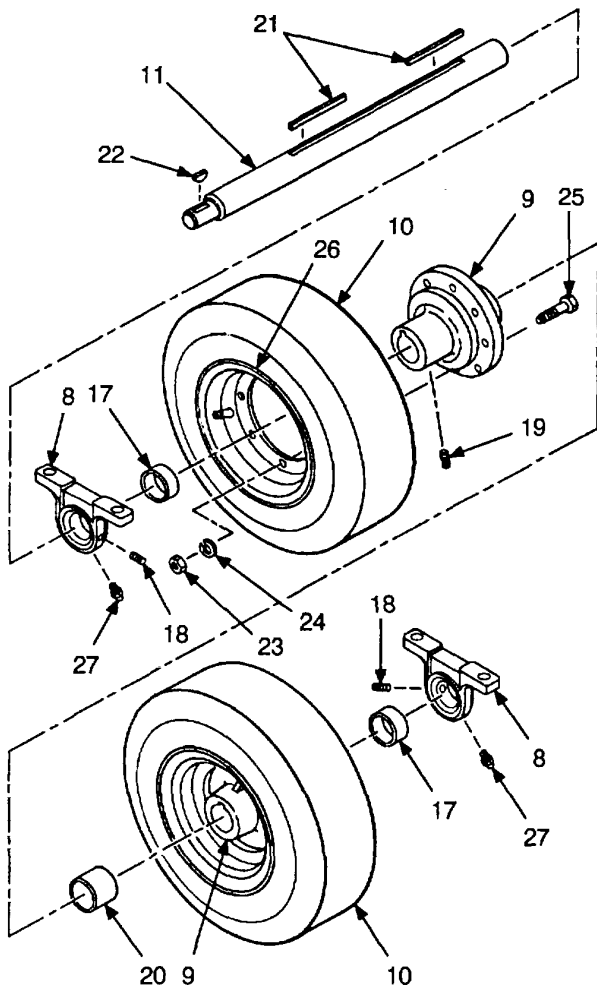

- (4) Install key (21) in shaft (11). Tap shaft through one hub (9). Ensure that valve stem (28) on tire (10) faces outside.
- (5) Slide spacer (20) onto shaft (11), then install second key (21).
- (6) Tap shaft (11) through remaining hub (9). Ensure that valve stem on tire (10) faces outside.
- (7) If necessary, install two setscrews (18) in each bearing (8).
- (8) Slide spacer (17) and bearing (8) on each side of shaft (11).
- (9) Install woodruff key (22) in shaft (11).

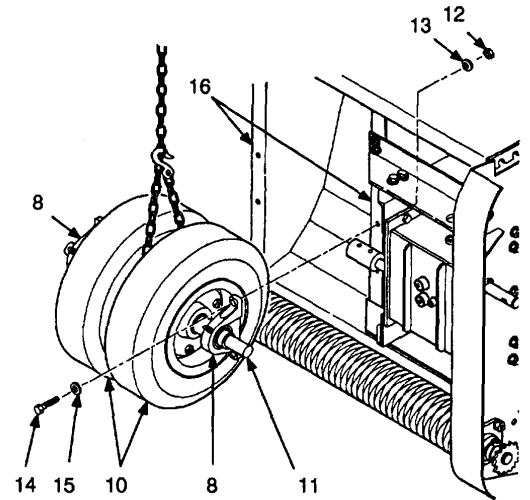

d. *Assembly.*

- (1) Install lubrication fitting (27) in each bearing (8).
- (2) Install hub (9) on rims (26) using eight screws (25), new lockwashers (24), and nuts (23). Hub must be installed from side of tire opposite valve stem (28) with lip (29) facing valve stem. Tighten hub mounting nuts to 39 lb-ft.
- (3) Inflate tires (10) to 65 psi.

e. *Installation.*

- (1) Wrap a lifting sling or chain around shaft (11) in between tires (10).
- (2) Using a suitable lifting device, raise shaft (11) and tires (10) and position for installation.
- (3) Secure each bearing (8) to bearing supports (16) using two screws (14), flatwashers (15), new lockwashers (13), and nuts (12). Tighten bearing mounting screws to 60 lb-ft.

14-41. TRACTION WHEEL ASSEMBLY REPAIR (CONT).

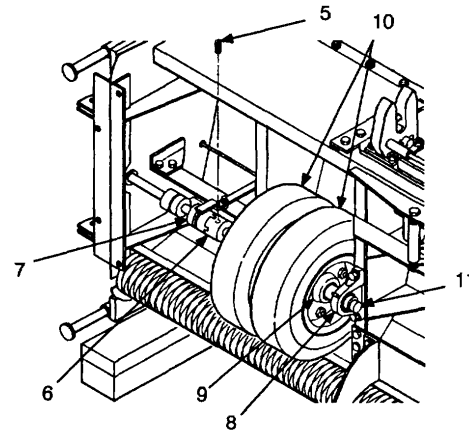
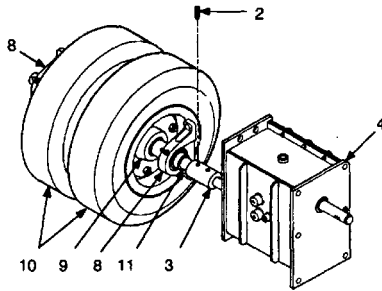

NOTE

Step (4) is for gearbox side of spreader only.

- (4) On gearbox side of spreader, slide shaft (11) into clutch (3), then tighten setscrew (2) in clutch (3) and two setscrews in each bearing (8). Center tires (10) in opening, then tighten setscrew in each hub (9).

NOTE

Step (5) is for agitator control clutch side of spreader only.

- (5) On agitator clutch control side of spreader, adjust position of shaft (11) so that bearing (6) and clutch (7) are disengaged when agitator clutch control lever is pushed in and engaged when agitator clutch control lever is pulled out. Tighten setscrew (5) in bearing (6), then tighten two setscrews in each bearing (8). Center tires (10) in opening, then tighten setscrew in each hub (9).
- (6) Check tire rotation. Tires should rotate freely. If necessary, adjust position of bearings (8) until tires rotate freely.

WARNING

Do not allow heavy components to swing while suspended by a lifting device. Exercise extreme caution when working near a cable under tension. Failure to follow this warning may result in severe injury to personnel.

NOTE

Two people should balance spreader while the third person operates lifting device.

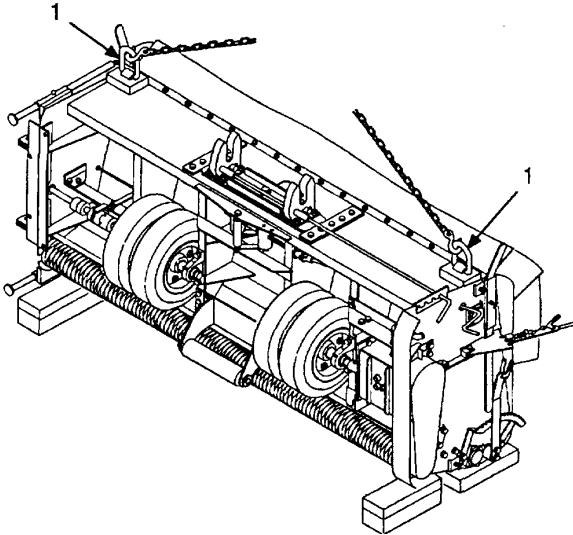

- (7) Connect lifting slings or chains to D-rings (1) at front of hopper.

- (8) Using a suitable lifting device, slowly lift spreader (2000 lb) until it is suspended from D-rings (1) at front of hopper.
- (9) Remove blocking from under spreader.
- (10) Slowly lower spreader to ground, then remove lifting slings or chains from D-rings (1).

FOLLOW-ON MAINTENANCE:

- Lubricate bearings (Chapter 3, Section I).
- Install transport truck and tongue on spreader (para4-12) or Install operator's platform on spreader (para4-14).
- Install toolbox (para 4-27).

Section VI. PREPARATION FOR STORAGE OR SHIPMENT

4-42. ADMINISTRATIVE STORAGE.

a. *General.* This section contains requirements and procedures for administrative storage of equipment that is issued to and in use by Army activities worldwide.

The requirements specified herein are necessary to maintain equipment in administrative storage in such a way as to achieve the maximum readiness condition.

Equipment that is placed in administrative storage should be capable of being readied to perform its mission within 24 hours, or as otherwise may be prescribed by the approving authority. Before equipment is placed in administrative storage, a current PMCS should be completed and deficiencies corrected.

Report equipment in administrative storage as prescribed for all reportable equipment.

Perform inspections, maintenance services, and lubrication as specified herein.

Records and reports to be maintained for equipment in administrative storage are the same as those prescribed by DA Pam 738-750 for equipment in use.

A 10 percent variance is acceptable on time, running hours, or mileage used to determine the required maintenance actions.

Performance of applicable PMCS, as mentioned throughout this section, will be on a quarterly basis.

b. *Definition of Administrative Storage.* Equipment is placed in administrative storage when a shortage of maintenance effort exists. Items placed in administrative storage should be ready for use within the time factors determined by the directing authority. During the storage period, appropriate maintenance records will be kept.

c. *Preparation of Equipment for Administrative Storage.*

- (1) Storage Site.
 - (a) Select the best available site for administrative storage. Separate stored equipment from equipment in use. Conspicuously mark the area "Administrative Storage".
 - (b) Covered space is preferred.

4-42. ADMINISTRATIVE STORAGE (CONT).

- (c) Open sites should be improved hardstand, if available. Unimproved sites should be firm, well-drained, and kept free of excessive vegetation.
- (2) Storage Plan.
- (a) Store equipment so as to provide maximum protection from the elements and to provide access for inspection, maintenance, and exercising. Anticipate removal or deployment problems and take suitable precautions.
 - (b) Take into consideration environmental conditions such as extreme heat or cold; high humidity; blowing sand, dust, or loose debris; soft ground; mud; heavy snows; or combinations thereof, and take adequate precautions.
 - (c) Establish a fire plan and provide for adequate fire fighting equipment and personnel.
- (3) Maintenance Services and Inspection.
- (a) Prior to storage, perform the next scheduled unit PMCS.
 - (b) Inspect and approve the equipment prior to storage. Do not place equipment in storage in a nonmission-capable condition.
- (4) Basic Issue Items.
- (a) Process basic issue items with the major item to which they are assigned.
 - (b) If possible, store basic issue items with the major item.
 - (c) If stored apart from the major item, mark basic issue items with tags indicating the major item, its registration or serial number, and its location. In addition, place a tag or list indicating the location of the removed items in a conspicuous place on the major item. Store basic issue items in protective closures.

- (5) Correction of Shortcomings and Deficiencies. Correct all shortcomings and deficiencies prior to storage, or obtain a deferment from the approving authority.
- (6) Lubrication. Lubricate equipment in accordance with instructions in Chapter 3, Section I.
- (7) General Cleaning, Painting, and Preservation.

CAUTION

Do not direct water or steam, under pressure, against unsealed electrical systems or any exterior opening. Failure to follow this caution may result in damage to equipment.

- (a) Cleaning. Clean the equipment of dirt, grease, and other contaminants, but do not use vapor degreasing.
- (b) Painting. Remove rust and damaged paint by scraping, wire brushing, sanding, or buffing. Sand to a smooth finish and spot paint as necessary (TB 43-0209).
- (c) Preservation. After cleaning and drying, immediately coat unpainted metal surfaces with oil or grease, as appropriate.

CAUTION

Place a piece of barrier material (Item 1, Appendix E) between desiccant bags and metal surfaces.

NOTE

Air circulation under draped covers reduces deterioration from moisture and heat.

- (d) Weatherproofing. Sunlight, heat, moisture (humidity), and dirt tend to accelerate deterioration. Close and secure all openings except those required for venting and draining. Seal openings to prevent the entry of rain, snow, or dust. Insert desiccant when complete seal is required. Place equipment and provide blocking or framing to allow for ventilation and water drainage. Support cover away from item surfaces that may rust, rot, or mildew.

d. *Care of Equipment in Administrative Storage.*

- (1) Maintenance Services. After equipment has been placed in administrative storage, inspect, service, and exercise as specified herein.
- (2) Inspection. Inspection will usually be visual and must consist of at least a walk-around examination of all equipment to detect any deficiencies. Inspect equipment in open storage weekly and equipment in covered storage monthly. Inspect all equipment immediately after any severe storm or environmental change. The following are examples of things to look for during a visual inspection:
 - (a) Low or flat tires.
 - (b) Condition of preservatives, seals, and wraps.
 - (c) Corrosion or other deterioration.
 - (d) Missing or damaged parts.
 - (e) Water in compartments.
 - (f) Any other readily recognizable shortcomings or deficiencies.
- (3) Repair During Administrative Storage. Keep equipment in an optimum state of readiness. Accomplish the required services and repairs as expeditiously as possible. Whenever possible, perform all maintenance on-site.
- (4) Exercising. Exercise equipment in accordance with Table 4-3 and the following instructions.
 - (a) Major Exercise. Depreserve equipment by removing only that material restricting exercise. Remove any blocking and perform all before-operation checks. Operate all functional components and perform all during and after-operation checks.
 - (b) Scheduled Services. Scheduled services will include inspection per subparagraph 4-42d(2) above, and will be conducted in accordance with Table 4-3. Lubricate in accordance with instructions in Chapter 3, Section I.
 - (c) Corrective Action. Immediately take action to correct shortcomings and deficiencies noted. Record inspection and exercise results on DA Form 2404. Record and report all maintenance

actions on DA Form 2407. After exercising, restore the preservation to the original condition. Replenish lubricants used during exercising, and note the amount on DA Form 2408.

- (d) Rotation. Rotate items in accordance with any rotational plan that will keep the equipment in an operational condition and reduce the maintenance effort.

e. *Procedures for Common Components and Miscellaneous Items.*

- (1) Tires. Visually inspect tires during each walk-around inspection. This inspection includes checking tires with a tire gage. Inflate, repair, or replace as necessary those found to be low, damaged, or excessively worn. Mark inflated and repaired tires with a crayon for checking at the next inspection.
- (2) Seals. Seals may develop leaks during storage, or shortly thereafter. If leaking persists, refer to the applicable maintenance section in this manual for corrective maintenance procedures.

f. *Removal of Equipment from Administrative Storage.*

- (1) Activation. Prepare the equipment for normal operation in accordance with the instructions contained in Chapter 2, Section III.
- (2) Servicing. Resume the maintenance service schedule in effect at the commencement of storage, or service the equipment before the scheduled dates in order to produce a staggered maintenance workload.

4-43. PREPARATION FOR SHIPMENT.

- a. The spreader should be shipped in its transport configuration. Refer to paragraph 4-14 for instructions on preparing the operator's platform for shipment. Refer to paragraphs 4-12 and 4-11 for instructions on installing the transport truck and the taillights on the spreader.
- b. Reduce pressure in all tires by 10 percent before shipping spreader.
- c. Refer to TM 55-200, TM 55-601, and TM 743-200-1 for additional instructions on processing, storage, and shipment of materiel.

4-43. PREPARATION FOR SHIPMENT (CONT).

- d. Spreaders that have been removed from storage for shipment do not have to be reprocessed if they will reach their destination within the administrative storage period. Reprocess only if inspection reveals any corrosion or if anticipated in-transit weather conditions make it necessary.
- e. When a spreader is received and has already been processed for domestic shipment, as indicated on

DD Form 1397, it does not have to be reprocessed for storage unless corrosion and deterioration are found during the inspection upon receipt. List on SF 364 all discrepancies found because of poor preservation, packaging, packing, marking, handling, loading, storage, or excessive preservation. Repairs that cannot be handled by the receiving unit must have tags attached listing needed repairs. A report of these conditions will be submitted by the unit commander for action by a direct support maintenance unit.

Table 4-3. EXERCISE SCHEDULE

Weeks	2	4	6	8	10	12	14	16	18	20	22	24
PMCS						•						•
Scheduled Services		•		•		•		•		•		
Major Exercise												•

**CHAPTER 5
DIRECT SUPPORT AND GENERAL SUPPORT MAINTENANCE**

		Page			Page
5-1	Tire Repair	5-1	5-4	Agitator Repair	5-14
5-2	Coupler Hitch and Crank Repair	5-1	5-5	Feed Roll Replacement	5-23
5-3	Gearbox Repair.....	5-7			

5-1. TIRE REPAIR.

Refer to TM 9-2610-200-14 for tire repair procedures.

5-2. COUPLER HITCH AND CRANK REPAIR.

- This task covers:
- | | | | |
|----|-------------------------|----|--------------|
| a. | Removal | d. | Assembly |
| b. | Disassembly | e. | Installation |
| c. | Cleaning and Inspection | | |

INITIAL SETUP

Tools:

Shop Equipment, Automotive Maintenance and
Repair: Field Maintenance, Basic, Less Power

Personnel Required: Two

Materials/Parts:

- Marker tags (Item 13, Appendix E)
- Two locknuts
- Nine cotter pins
- Twenty-six lockwashers

5-2. COUPLER HITCH AND CRANK REPAIR (CONT).

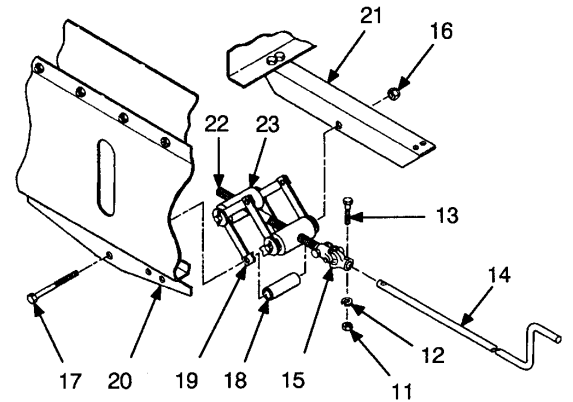
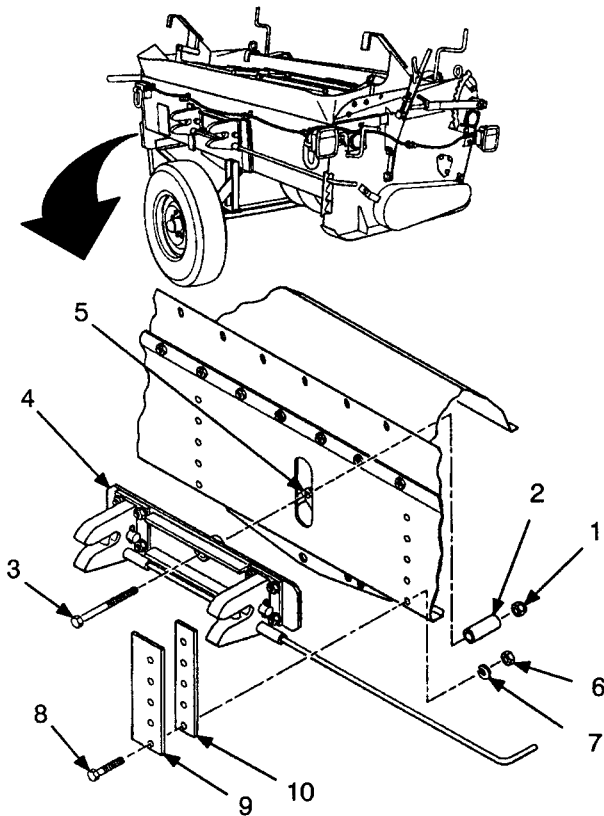

a. *Removal.*

- (1) Remove locknut (1), spacer (2), and bolt (3) securing bar assembly (4) to upper pantograph links (5). Discard locknut.

WARNING

Bar assembly will be unsupported when mounting screws are removed. Use assistance when removing bar assembly. Failure to follow this warning could cause injury.

- (2) Remove ten nuts (6), lockwashers (7), and screws (8) securing two spacer plates (9), two spacer guides (10), and bar assembly (4) to spreader. Remove plates, guides, and bar assembly. Discard lockwashers.

- (3) Remove nut (11), lockwasher (12), and screw (13) securing hitch adjusting crank (14) to universal joint (15). Remove hitch adjusting crank from left side of spreader. Discard lockwasher.
- (4) Remove locknut (16), bolt (17), and spacer (18) securing lower pantograph links (19) to coupler support bracket (20) and coupler angle (21). Remove pantograph links, screw (22), nut housings (23), and universal joint (15) as an assembly. Discard locknut.

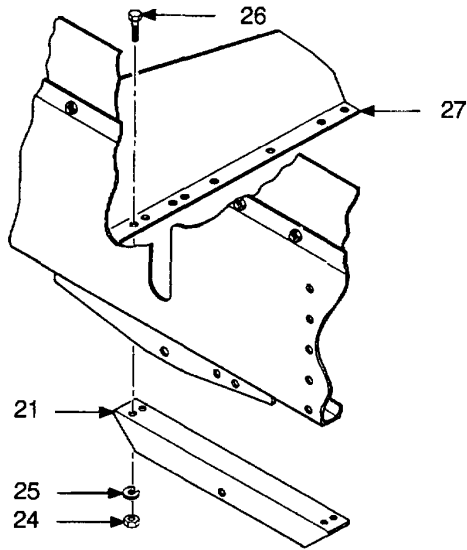

- (5) Remove four nuts (24), lockwashers (25), and screws (26) securing coupler angle (21) to bearing support brackets (27). Remove coupler angle. Discard lockwashers.

b. Disassembly.

- (1) Remove nut (28), lockwasher (29), and screw (30) securing universal joint (15) to adjusting screw (22). Remove universal joint. Discard lockwasher.
- (2) Remove lubrication fitting (31) from universal joint (15).
- (3) Remove two cotter pins (32) and flatwashers (33) from each nut housing (23). Remove

upper pantograph links (5) and lower pantograph links (19) from nut housings. Discard cotter pins.

NOTE

Nut housings are tapped for left-hand and right-hand threads. Tag nut housings before removing from adjusting screw.

- (4) Unscrew and remove two nut housings (23) from adjusting screw (22).
- (5) Remove screw (34) and lockwasher (35) securing each latch (36) to latch lever (37). Discard lockwashers.
- (6) Remove latch lever (37) from two housings (38). Latches (36) will come out as latch lever is removed.
- (7) Remove four nuts (39), lockwashers (40), and bolts (41) securing each housing (38) to bar assembly (4). Remove housings from bar assembly. Discard lockwashers.
- (8) Remove two cotter pins (42) from each shaft (43). Remove shaft, dog (44), and spring (45) from each housing (38). Discard cotter pins.

5-2. COUPLER HITCH AND CRANK REPAIR (CONT).

c. Cleaning and Inspection.

WARNING

Dry cleaning solvent P-D-680 is toxic and flammable. Wear protective goggles, face mask, and gloves and use in a well ventilated area. Avoid contact with skin, eyes, and clothes and do not breath vapors. Do not use near open flame or excessive heat. The flash point for Type I solvent is 100 degrees F (38 degrees C). The flash point for Type II solvent is 140 degrees F (60 degrees C). If you become dizzy while using cleaning solvent, get fresh air immediately and get medical aid. If contact with eyes is made, wash your eyes with water and get medical aid immediately.

- (1) Clean all parts with dry cleaning solvent and dry thoroughly.
- (2) Inspect all parts for cracks, breaks, or other damage. Replace all damaged parts.

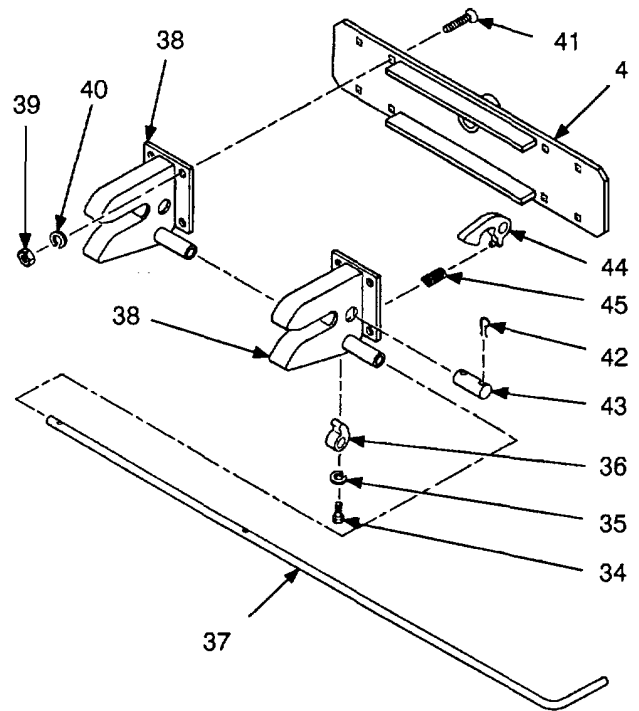

d. Assembly.

- (1) Position spring (45) and dog (44) inside housing (38) and install shaft (43). Secure shaft using two new cotter pins (42). Repeat for remaining housing.
- (2) Install each housing (38) on bar assembly (4) using four bolts (41), new lockwashers (40), and nuts (39). Tighten housing mounting bolts to 60 lb-ft.
- (3) Position latch (36) inside each housing (38) and install latch lever (37) through housings. Secure each latch to latch lever using screw (34) and new lockwasher (35).

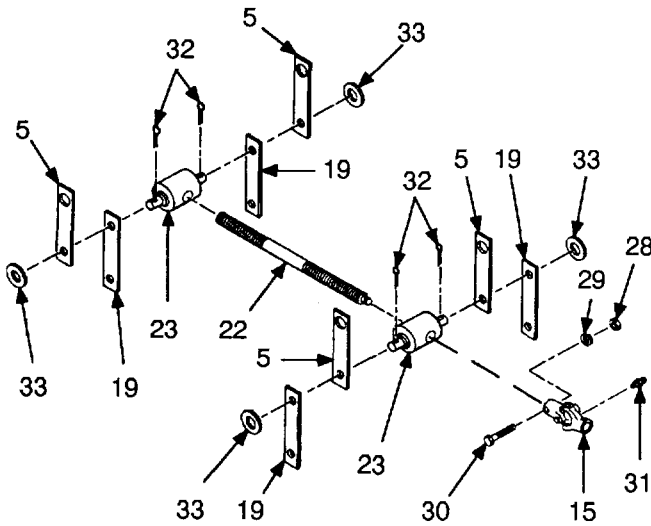

NOTE

Nut housings are tapped for right-hand and left-hand threads. Ensure that nut housings are installed in proper location on adjusting screw.

- (4) Screw nut housings (23) onto adjusting screw (22). Remove tags.

NOTE

Upper pantograph links have one large hole and one small hole. Lower pantograph links have two holes the same size. Install upper pantograph links on nut housing using smaller hole.

- (5) On one nut housing (23), install one lower pantograph link (19) on each end, then install one upper pantograph link (5) on each end. Secure to nut housing using two flatwashers (33) and new cotter pins (32).

- (6) On other nut housing (23), install one upper pantograph link (5) on each end, then install one lower pantograph link (19) on each end. Secure to nut housing using two flatwashers (33) and new cotter pins (32).
- (7) Install lubrication fitting (31) in universal joint (15).
- (8) Install universal joint (15) on adjusting screw (22) using screw (30), new lockwasher (29), and nut (28).

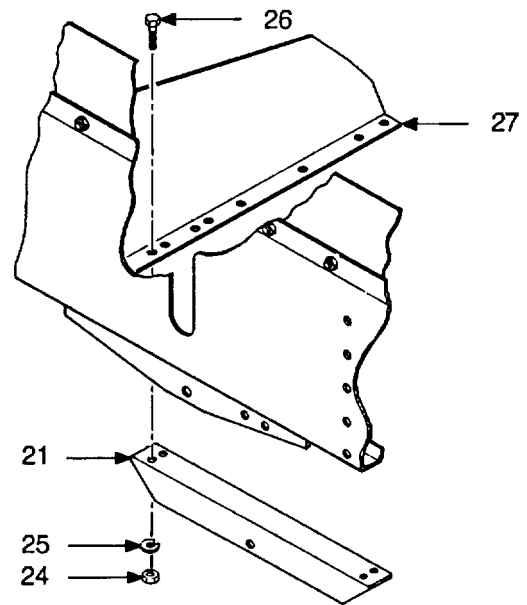

e. Installation.

- (1) Install coupler angle (21) on bearing support brackets (27) using four screws (26), new lockwashers (25), and nuts (24). Tighten coupler and mounting bolts to 60 lb-ft.

5-2. COUPLER HITCH AND CRANK REPAIR (CONT).

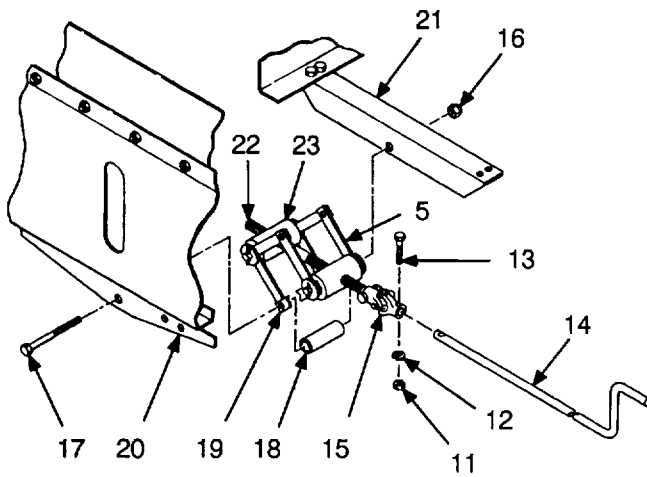

- (2) Position the assembled pantograph links (5 and 19), screw (22), and nut housings (23) for installation on coupler support bracket (20) and coupler angle (21).

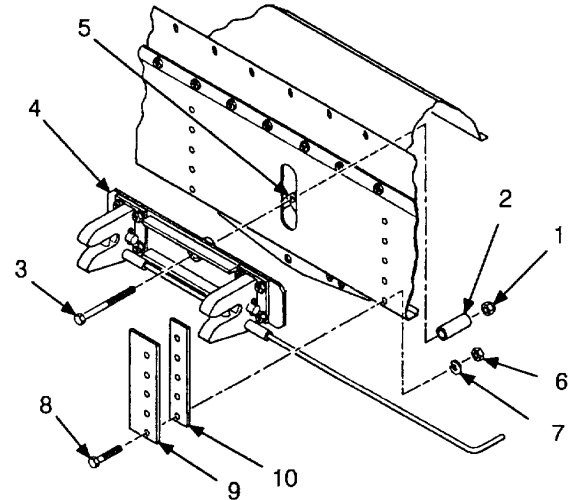

WARNING

Bar assembly will be unsupported until mounting hardware is installed. Use assistance when installing bar assembly. Failure to follow this warning could cause injury.

- (7) Install bar assembly (4), two spacer guides (10), and two spacer plates (9) on spreader using 10 screws (8), new lockwashers (7), and nuts (6). Tighten bar assembly mounting screws to 60 lb-ft.
- (8) Assemble upper pantograph links (5) as shown, then install bolt (3) and spacer (2).

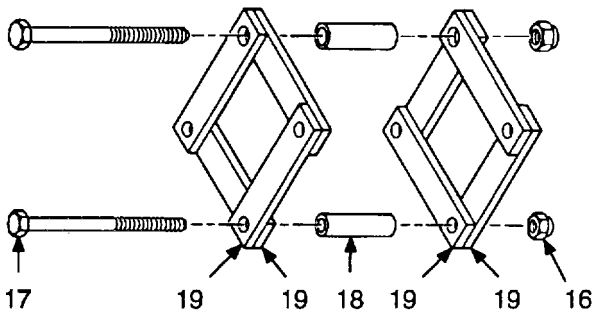

NOTE

Upper pantograph links have large hole. Lower pantograph links have small hole.

- (3) Assemble lower pantograph links (19) as shown, then install bolt (17) and spacer (18).

NOTE

Do not overtighten locknut. Pantograph links must be free to open and close.

- (4) Secure bolt (17) using new locknut (16).
- (5) Install hitch adjusting crank (14) through side of spreader.

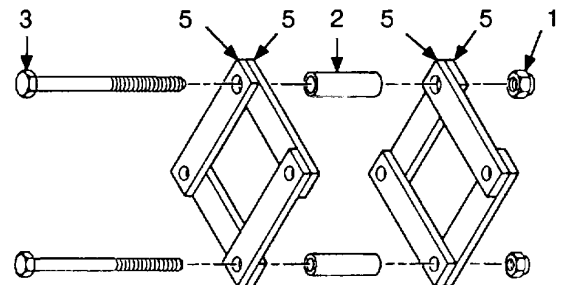

NOTE

Do not overtighten locknut. Pantograph links must be free to open and close.

- (9) Secure bolt (3) using new locknut (1).

FOLLOW-ON MAINTENANCE:

- Lubricate coupler hitch housing, adjusting screw, and universal joint (Chapter 3, Section 1).
- Raise and lower coupler hitch and check for binding. If hitch binds, check alinement of pantograph links.

5-3. GEARBOX REPAIR.

- This task covers:
- a. Disassembly
 - b. Cleaning and Inspection
 - c. Assembly

INITIAL SETUP

Tools:

Shop Equipment, Automotive Maintenance and Repair: Field Maintenance, Basic, Less Power

Materials/Parts:

- One cotter pin
- Two retaining rings
- Two seals
- Four gaskets
- Twenty-one lockwashers

References:

TM 9-214

Equipment Conditions:

Reference
Para 4-37 Gearbox removed.

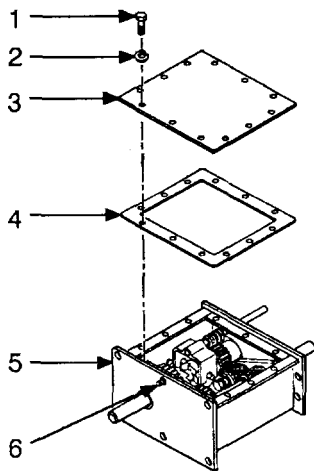

a. Disassembly.

- (1) Remove 12 screws (1) and lockwashers (2). Remove cover (3) and gasket (4) from gearbox (5). Discard lockwashers and gasket.
- (2) Remove mounting screw (6) from gearbox (5).

5-3. GEARBOX REPAIR (CONT).

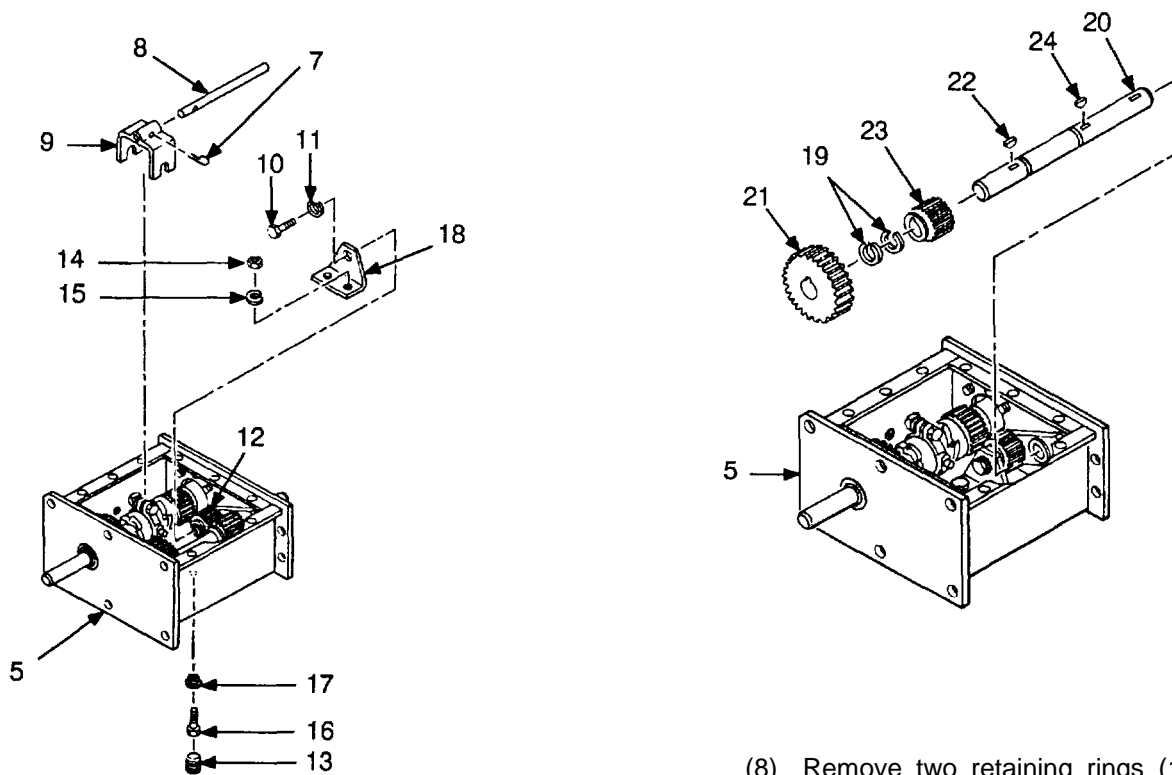

- (3) Remove cotter pin (7) securing throwout shaft (8) to fork (9). Remove throwout shaft from gearbox (5). Discard cotter pin.
- (4) Remove fork (9).
- (5) Remove screw (10) and lockwasher (11) from idler gear (12). Discard lockwasher.
- (6) Remove two pipe plugs (13) from bottom of gearbox (5).
- (7) Remove two nuts (14), lockwashers (15), screws (16), and gaskets (17). Remove idler support bracket (18). Discard lockwashers and gaskets.

- (8) Remove two retaining rings (19) from drive shaft (20). Discard retaining rings.
- (9) Slide reverse spur gear (21) toward center of gearbox (5) and remove key (22) from drive shaft (20).
- (10) Slide forward spur gear (23) toward center of gearbox (5) and remove key (24) from drive shaft (20).
- (11) Remove drive shaft (20) and two gears (21 and 23) from gearbox (5).

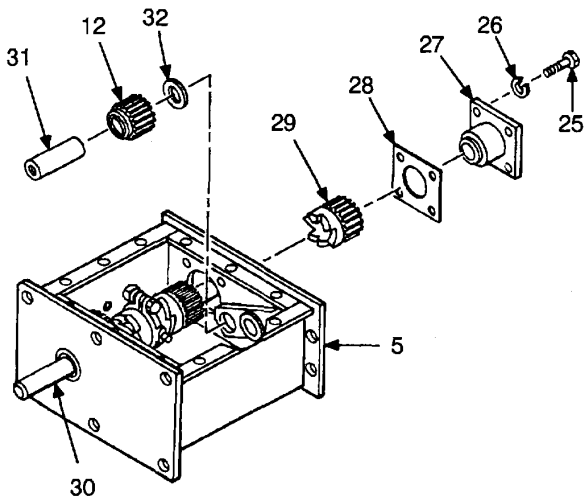

- (12) Remove four screws (25) and lockwashers (26). Remove plate (27) and gasket (28) from gearbox (5). Discard gasket and lockwashers.
- (13) Remove spur gear (29) from drive shaft (30).
- (14) Remove idler gear (12), shaft (31), and thrust washer (32) from gearbox (5).
- (15) Remove idler gear (12) from shaft (31).

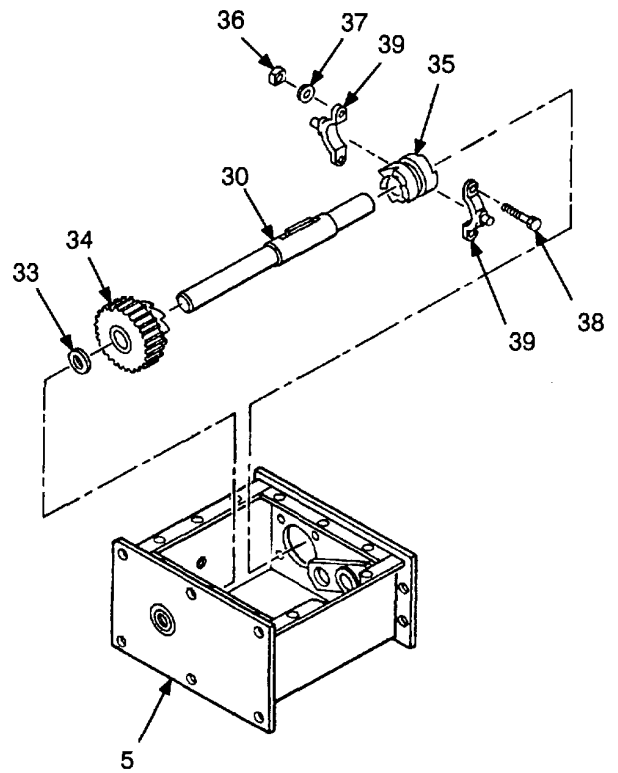

- (16) Remove thrust washer (33) and clutch gear (34) from drive shaft (30).
- (17) Remove clutch (35) from drive shaft (30).
- (18) Remove drive shaft (30) from gearbox (5).
- (19) Remove two nuts (36), lockwashers (37), and screws (38). Remove clamp (39) from clutch (35). Discard lockwashers.

5-3. GEARBOX REPAIR (CONT).

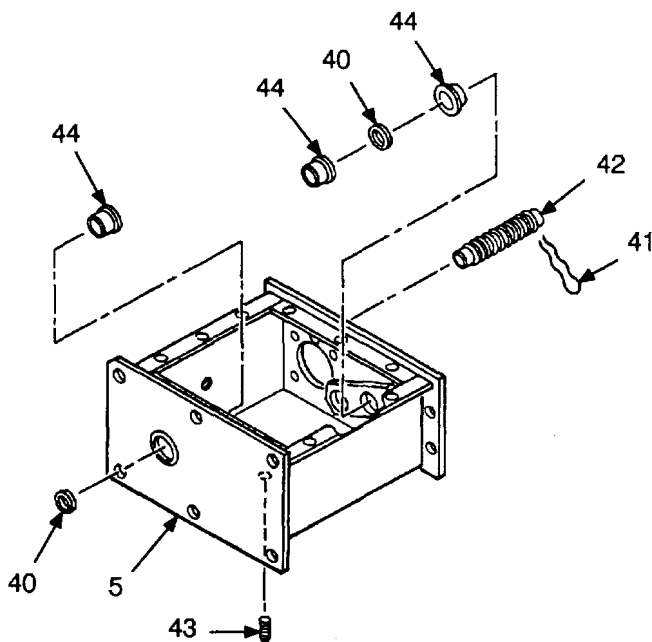

- (20) Remove two seals (40) from gearbox (5). Discard seals.
- (21) Remove wire (41) and bellows (42) from gearbox (5).
- (22) Remove drain plug (43) from gearbox (5).

NOTE

Clean and inspect bearings and bushings in accordance with TM 9-214. Do not remove bushings and bearings unless replacement is required.

- (23) Remove three bushings (44) from gearbox (5).

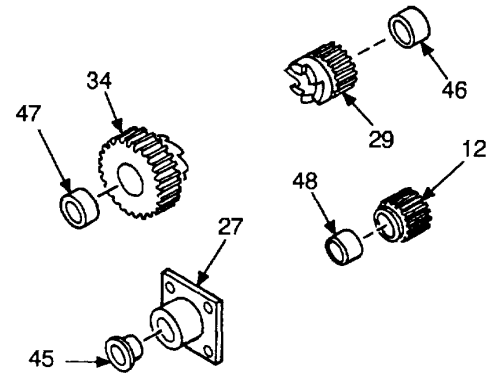

- (24) Remove bushing (45) from plate (27).
- (25) Remove bearing (46) from spur gear (29).
- (26) Remove bearing (47) from clutch gear (34).
- (27) Remove bearing (48) from idler gear (12).

b. Cleaning and Inspection.

WARNING

Dry cleaning solvent P-D-680 is toxic and flammable. Wear protective goggles, face mask, and gloves and use in a well ventilated area. Avoid contact with skin, eyes, and clothes and do not breath vapors. Do not use near open flame or excessive heat. The flash point for Type I solvent is 100 degrees F (38 degrees C). The flash point for Type II solvent is 140 degrees F (60 degrees C). If you become dizzy while using cleaning solvent, get fresh air immediately and get medical aid. If contact with eyes is made, wash your eyes with water and get medical aid immediately.

- (1) Clean all parts with dry cleaning solvent and dry thoroughly.
- (2) Inspect all parts for cracks, breaks, or other damage. Replace all damaged parts.

c. Assembly.

NOTE

Perform steps (1) through (5) as applicable.

- (1) Install bearing (48) in idler gear (12).
- (2) Install bearing (47) in clutch gear (34).
- (3) Install bearing (46) in spur gear (29).
- (4) Install bushing (45) in plate (27).

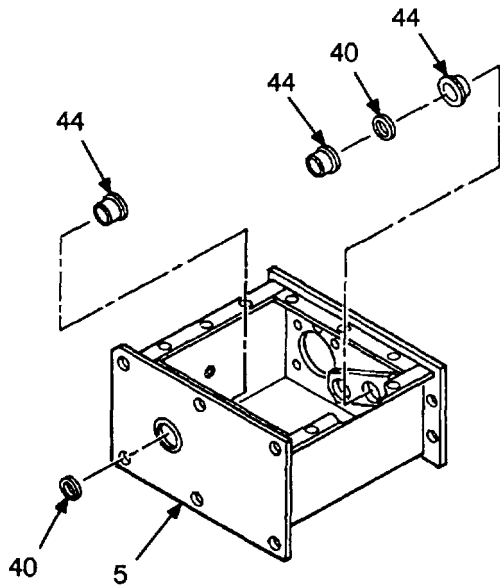

- (5) Install three bushings (44) in gearbox (5).
- (6) Install two new seals (40) in gearbox (5).

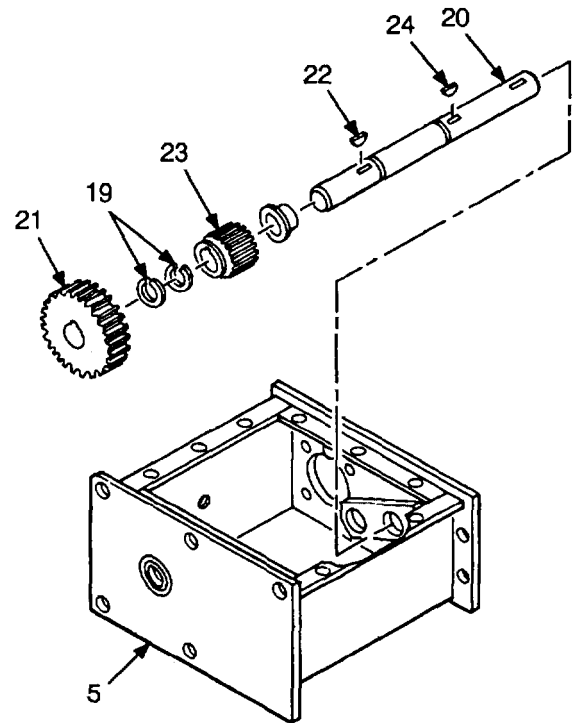

- (7) Position forward spur gear (23) in gearbox (5) and partially install drive shaft (20).
- (8) Slide two new retaining rings (19) onto drive shaft (20).
- (9) Install key (22) in drive shaft (20).
- (10) Position reverse spur gear (21) in gearbox (5) and fully install drive shaft (20).
- (11) Slide forward spur gear (23) toward center of gearbox (5) and install key (24) in drive shaft (20). Slide gear (23) over key.
- (12) Seat two retaining rings (19) to secure gears (21 and 23) to drive shaft (20).

5-3. GEARBOX REPAIR (CONT).

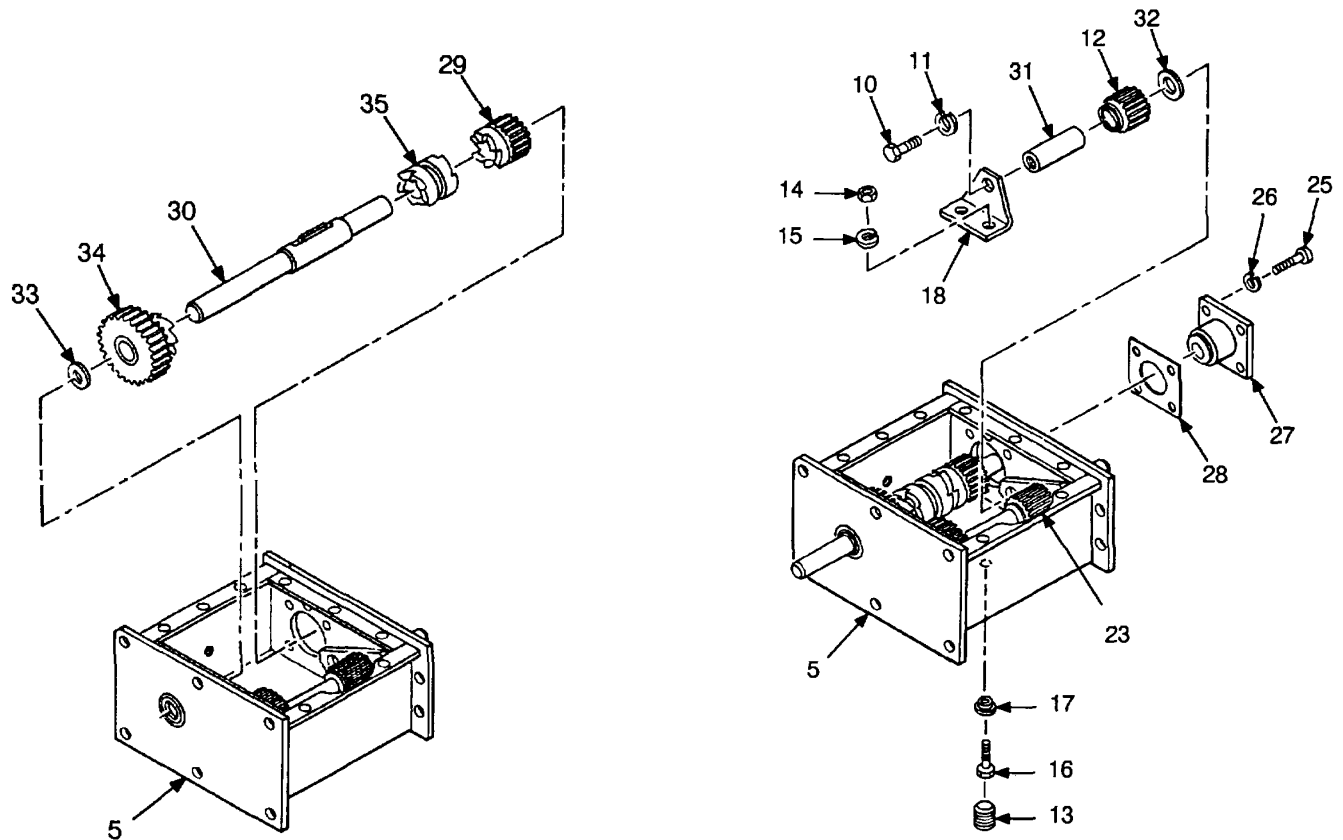

(13) Position thrust washer (33) and clutch gear (34) in gearbox (5) then install drive shaft (30) through side of gearbox into clutch gear.

(14) Slide clutch (35) onto drive shaft (30).

(15) Slide spur gear (29) onto drive shaft (30).

(16) Position idler gear (12) and thrust washer (32) in gearbox (5).

(17) Install shaft (31) through idler gear (12) and thrust washer (32) into gearbox (5). Ensure that idler gear (12) properly engages forward spur gear (23) after shaft is installed.

(18) Install plate (27) and new gasket (28) on gearbox (5) using four screws (25) and new lockwashers (26). Tighten plate mounting screws to 60 lb-ft.

(19) Secure idler support bracket (18) to shaft (31) using screw (10) and new lockwasher (11). Do not tighten screw.

(20) Secure idler support bracket (18) to gearbox (5) using two screws (16), new gaskets (17), new lockwashers (15), and nuts (14). Tighten support bracket mounting screws to 25 lb-ft, then tighten screw (10).

(21) Install two pipe plugs (13) in bottom of gearbox (5).

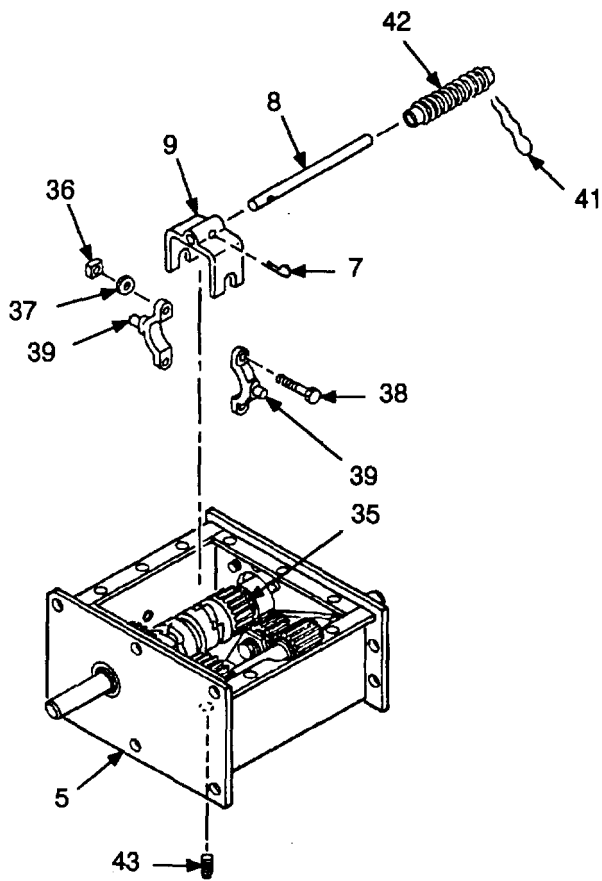

- (22) Install clamp (39) around clutch (35) using two screws (38), new lockwashers (37), and nuts (36). Tighten clamp mounting screws to 14 lb-ft.
- (23) Install bellows (42) in gearbox (5) and secure with wire (41).
- (24) Install fork (9) over clamp (39).
- (25) Install throwout shaft (8) through gearbox (5) and bellows (42). Secure throwout shaft to fork (9) using new cotter pin (7).
- (26) Install drain plug (43) in bottom of gearbox (5).

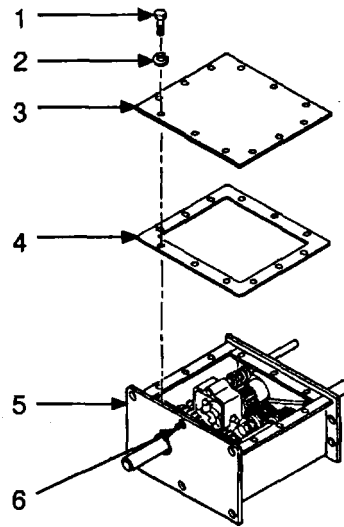

NOTE

Before installing gearbox cover, check gearbox for proper operation. Ensure that all gears turn freely and properly engage in both forward and reverse. Ensure that clutch slides freely on drive shaft and throwout shaft engages and disengages clutch without requiring excessive force.

- (27) Place new gasket (4) and cover (3) on gearbox (5) then install upper, middle gear cover mounting screw (6).
- (28) Secure cover (3) to gearbox (5) using 12 screws (1) and new lockwashers (2). Tighten cover mounting screws to 25 lb-ft in a cross pattern.

FOLLOW-ON MAINTENANCE:

- Install gearbox (para 4-37).
- Lubricate gearbox (Chapter 3, Section 1).

5-4. AGITATOR REPAIR.

- This task covers:
- a. Removal
 - b. Disassembly
 - c. Cleaning and Inspection
 - d. Assembly
 - e. Installation

INITIAL SETUP

Tools:

Shop Equipment, Automotive Maintenance and Repair: Field Maintenance, Basic, Less Power

Materials/Parts:

- Dry cleaning solvent (Item 11, Appendix E)
- One cotter pin
- Five locknuts
- Twenty-one lockwashers

Equipment Conditions:

Reference

- Para 4-14 Operator's platform removed from hopper.
- Para 4-38 Agitator drive chain removed.

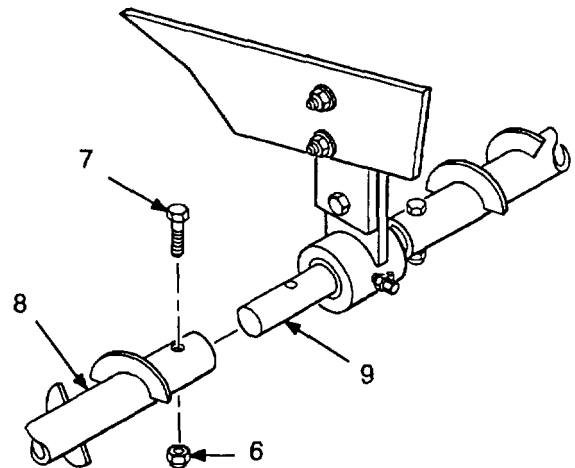
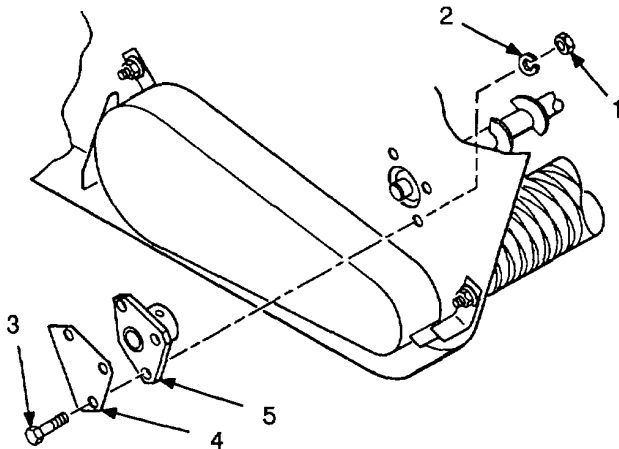

a. Removal.

- (1) On left side of spreader, remove three nuts (1), lockwashers (2), and screws (3) securing cover plate (4) and bushing (5) to spreader. Remove cover plate and bushing. Discard lockwashers.

- (2) Inside hopper, remove locknut (6) and screw (7) securing left side of agitator pipe assembly (8) to bushing (9). Discard locknut.

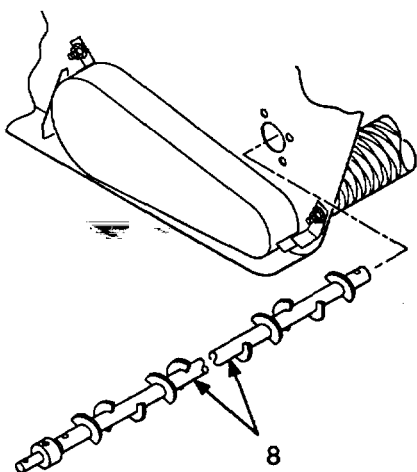

(3) Remove left side of agitator pipe assembly (8) through left side of spreader.

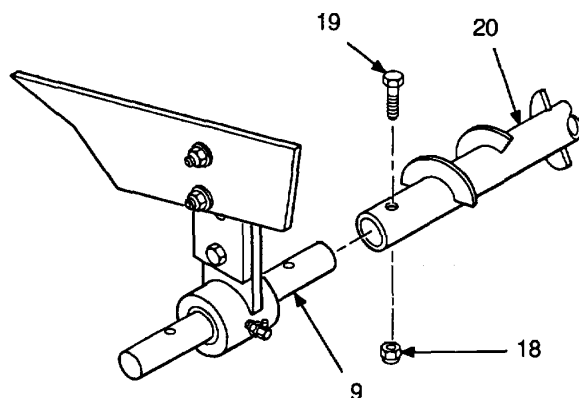

(6) Inside hopper, remove locknut (18) and screw (19) securing right side of agitator pipe assembly (20) to bushing (9). Discard locknut.

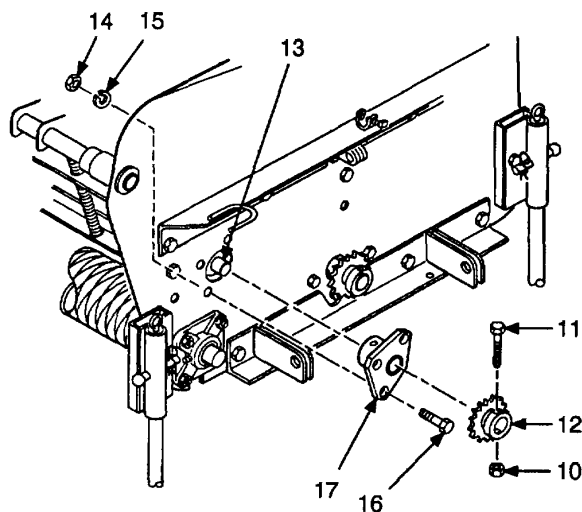

(4) On right side of spreader, remove nut (10), and screw (11) securing sprocket (12) to pin (13). Remove sprocket.

(5) Remove three nuts (14), lockwashers (15), and screws (16) securing bearing (17) to spreader. Remove bearing. Discard lockwashers.

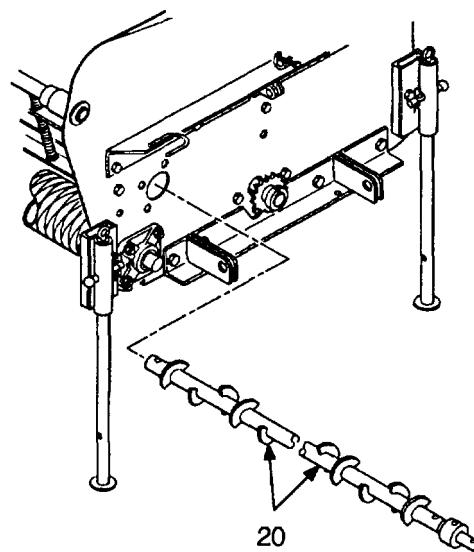

(7) Remove right side of agitator pipe assembly (20) through right side of spreader.

5-4. AGITATOR REPAIR (CONT).

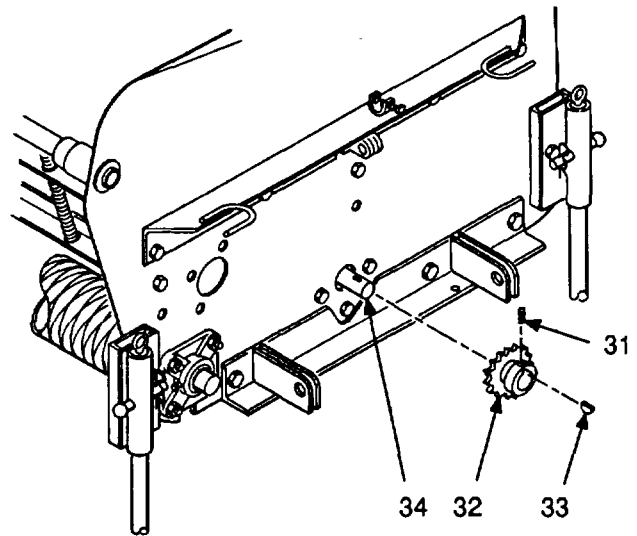
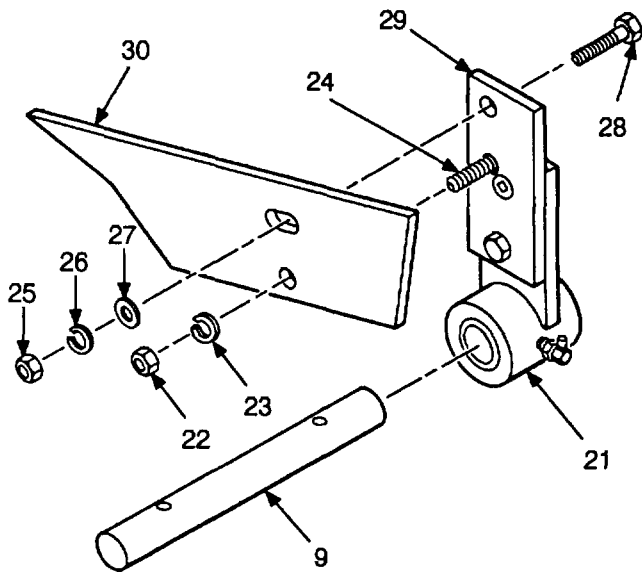

- (8) Inside hopper, remove bushing (9) from center bearing (21).
- (9) Remove nut (22) and lockwasher (23) from square neck bolt (24). Discard lockwasher.
- (10) Remove nut (25), lockwasher (26), flatwasher (27), and screw (28) securing bearing hanger (29) to center gusset (30). Removing bearing hanger and center bearing (21) from center gusset. Discard lockwasher.

- (11) On right side of spreader, loosen two setscrews (31) and remove sprocket (32) and key (33) from drive shaft (34).

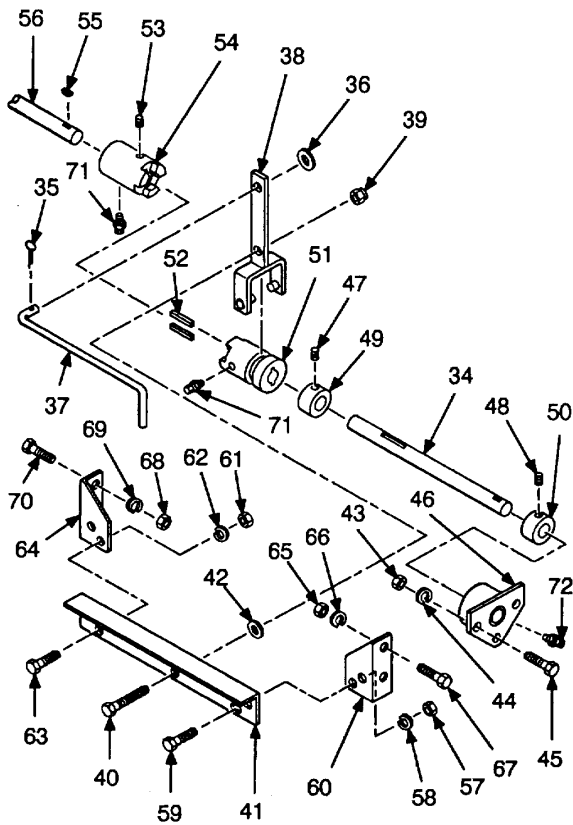

- (12) Remove cotter pin (35) and flatwasher (36) securing clutch shifting rod (37) to fork (38). Remove clutch shifting rod through right side of spreader. Discard cotter pin.
- (13) Remove locknut (39) and screw (40) securing fork (38) to bracket (41). Remove fork and flatwasher (42). Discard locknut.
- (14) Remove three nuts (43), lockwashers (44), and screws (45) securing bushing (46) to side of spreader. Remove bushing. Discard lockwashers.

- (15) Loosen setscrews (47 and 48) in collars (49 and 50).
- (16) Slide collars (49 and 50) and clutch (51) toward center of drive shaft (34). Remove collars, clutch, drive shaft, and bushing (46) as a unit.
- (17) Remove drive shaft (34) from bushing (46).
- (18) Remove two collars (49 and 50) from drive shaft (34).
- (19) Remove clutch (51) and two keys (52) from drive shaft (34).
- (20) Loosen setscrew (53) and remove clutch (54) and key (55) from traction drive axle (56).
- (21) Remove two nuts (57), lockwashers (58), and screws (59) securing bracket (41) to right angle (60). Discard lockwashers.
- (22) Remove two nuts (61), lockwashers (62), and screws (63) securing bracket (41) to left angle (64). Remove bracket. Discard lockwashers.
- (23) Remove nut (65), lockwasher (66), and screw (67) securing right angle (60) to side of hopper. Remove right angle. Discard lockwasher.

NOTE

If left angle (64) requires replacement, right-hand traction drive wheels will have to be removed (para 4-41).

- (24) Remove two nuts (68), lockwashers (69), and screws (70) securing left angle (64) to wheel bearing support. Remove left angle. Discard lockwashers.

b. Disassembly.

- (1) Remove lubrication fitting (71) from each clutch (51 and 54).
- (2) Remove lubrication fitting (72) from bushing (46).

5-4. AGITATOR REPAIR (CONT).

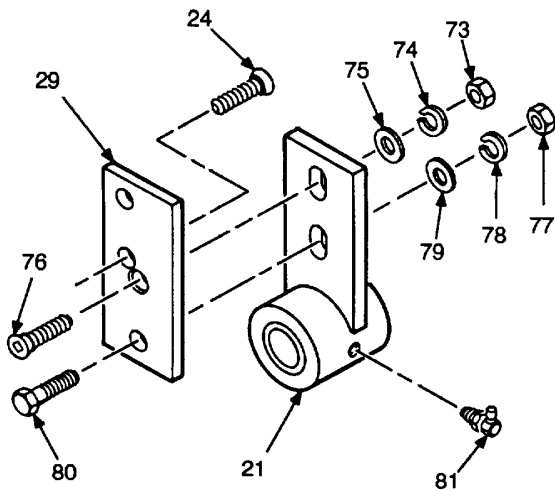

- (3) Remove nut (73), lockwasher (74), flatwasher (75), and square neck bolt (76) securing center bearing (21) to bearing hanger (29). Discard lockwasher.
- (4) Remove nut (77), lockwasher (78), flatwasher (79), and screw (80) securing center bearing (21) to bearing hanger (29). Remove center bearing from bearing hanger. Discard lockwasher.
- (5) Remove square neck bolt (24) from bearing hanger (29).
- (6) Remove lubrication fitting (81) from center bearing (21).

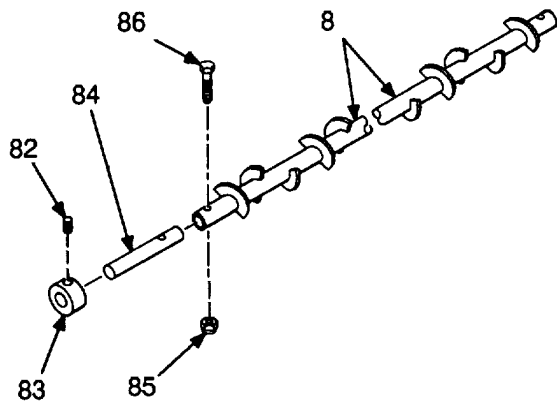

- (7) Loosen setscrew (82) and remove collar (83) from left-hand pipe end pin (84).

- (8) Remove locknut (85) and screw (86) securing left-hand pipe end pin (84) to left-hand side of agitator pipe assembly (8). Remove end pin from agitator pipe assembly. Discard locknut.

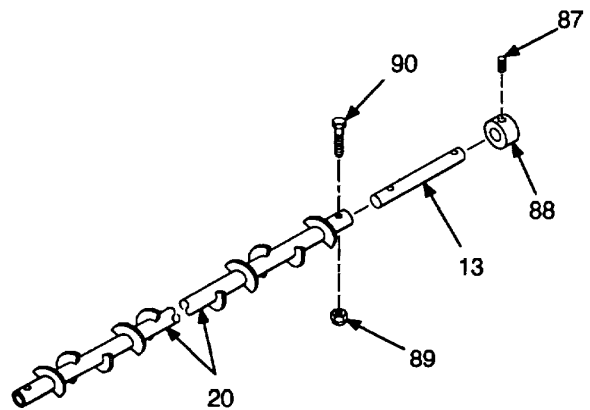

- (9) Loosen setscrew (87) and remove collar (88) from right-hand pipe end pin (13).
- (10) Remove locknut (89) and screw (90) securing right-hand pipe end pin (13) to right side of agitator pipe assembly (20). Remove end pin from agitator pipe assembly. Discard locknut.

c. *Cleaning and Inspection.*

WARNING

Dry cleaning solvent P-D-680 is toxic and flammable. Wear protective goggles, face mask, and gloves and use in a well ventilated area. Avoid contact with skin, eyes, and clothes and do not breath vapors. Do not use near open flame or excessive heat. The flash point for Type I solvent is 100 degrees F (38 degrees C). The flash point for Type II solvent is 140 degrees F (60 degrees C). If you become dizzy while using cleaning solvent, get fresh air immediately and get medical aid. If contact with eyes is made, wash your eyes with water and get medical aid immediately.

- (1) Clean all parts with dry cleaning solvent and dry thoroughly.
- (2) Inspect all parts for cracks, breaks, or other damage. Replace all damaged parts.

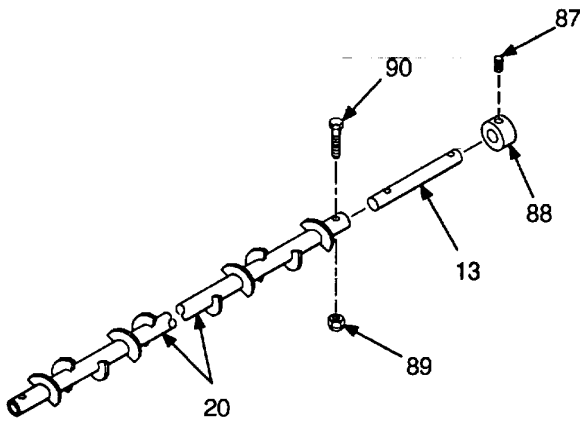

d. Assembly.

- (1) Install end pin (13) in right-hand side of agitator pipe assembly (20) and secure using screw (90) and new locknut (89).
- (2) Install collar (88) on right-hand pipe end pin (13) and tighten setscrew (87).

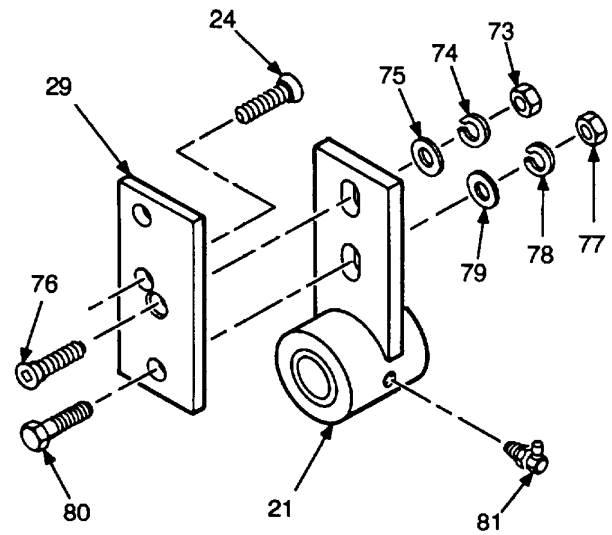

- (5) Install lubrication fitting (81) in center bearing (21).
- (6) Install square neck bolt (24) in bearing hanger (29).
- (7) Install center bearing (21) on bearing hanger (29) using square neck bolt (76), flatwasher (75), new lockwasher (74), and nut (73). Do not fully tighten mounting hardware.
- (8) Install screw (80), flatwasher (79), new lockwasher (78), and nut (77) to secure center bearing (21) to bearing hanger (29). Do not fully tighten mounting hardware.

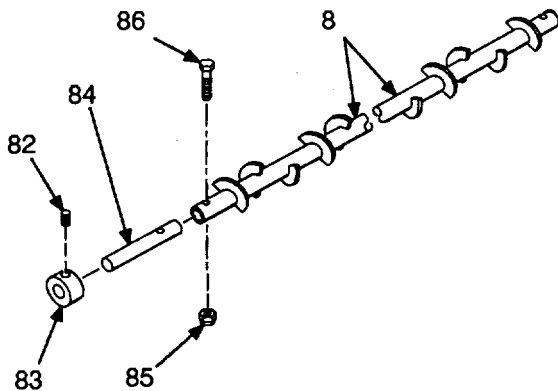

- (3) Install end pin (84) in left-hand side of agitator pipe assembly (8) and secure using screw (86) and new locknut (85).
- (4) Install collar (83) on left-hand pipe pin (84) and tighten setscrew (82).

5-4. AGITATOR REPAIR (CONT).

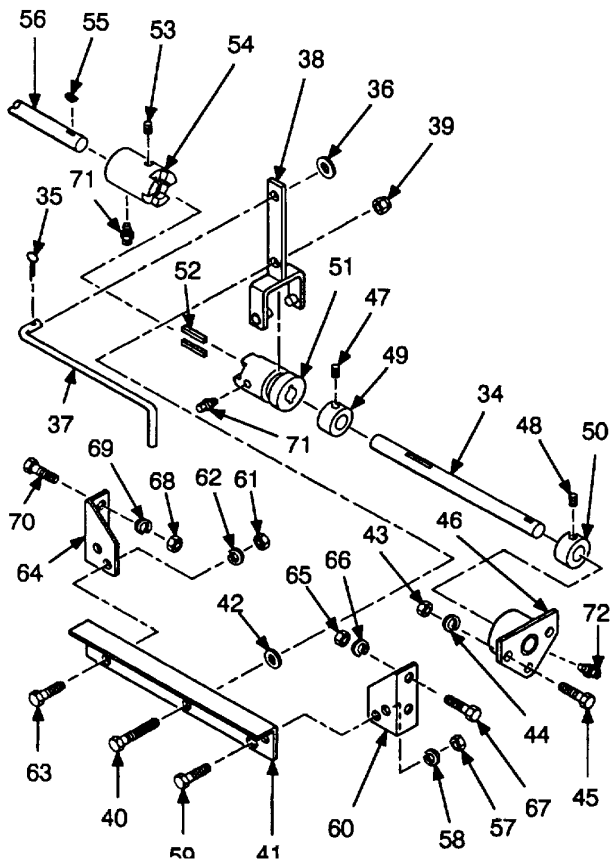

- (9) Install lubrication fitting (72) in bearing (46).
- (10) Install lubrication fitting (71) in each clutch (51 and 54).

e. Installation.

- (1) If necessary, install left angle (64) on wheel bearing support using two screws (70), new lockwashers (69), and nuts (68). Tighten angle mounting screws to 60 lb-ft. Install right-hand traction drive wheels (para 4-41).
- (2) Install right angle (60) on side of hopper using screw (67), new lockwasher (66), and nut (65). Install screw through upper mounting hole in right angle. Tighten angle mounting screw to 60 lb-ft.

- (3) Install bracket (41) on left angle (64) using two screws (63), new lockwashers (62), and nuts (61). Tighten bracket mounting screws to 60 lb-ft.
- (4) Secure bracket (41) to right angle (60) using two screws (59), new lockwashers (58), and nuts (57). Tighten bracket mounting screws to 60 lb-ft.
- (5) Install key (55) and clutch (54) on traction drive axle (56). Tighten setscrew (53).
- (6) Install drive shaft (34) in bearing (46).
- (7) Slide two collars (49 and 50) and clutch (51) onto drive shaft (34). Do not tighten setscrews (47 and 48) or install keys (52) at this time.
- (8) Install bushing (46), drive shaft (34), clutch (51) and two collars (49 and 50) as a unit on right side of spreader using three screws (45), new lockwashers (44), and nuts (43). Do not fully tighten mounting hardware at this time.
- (9) Install two keys (52) in drive shaft (34) then slide clutch (51) over keys.
- (10) Slide collar (50) against bushing (46) and tighten setscrew (48).
- (11) Install fork (38) over clutch (51). Secure fork to bracket (41) using screw (40), flatwasher (42), and new locknut (39). Do not fully tighten locknut, fork must be free to pivot.
- (12) Install clutch shift rod (37) through right side of hopper and secure to fork (38) using flatwasher (36) and new cotter pin (35).
- (13) Hold fork (38) in vertical position and slide collar (49) against clutch (51). Tighten setscrew (47) in collar.
- (14) Check operation of clutch before continuing. Clutch shift rod (37) must engage and disengage clutch halves (51 and 54) without excessive force. Ensure that clutch halves fully disengage when clutch shift rod is pulled out. If necessary, adjust position of collar (49).

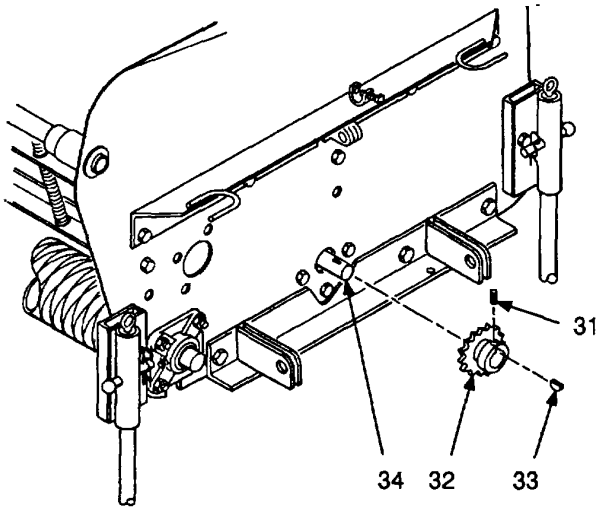

- (15) Install key (33) and sprocket (32) on drive shaft (34). Tighten two setscrews (31).

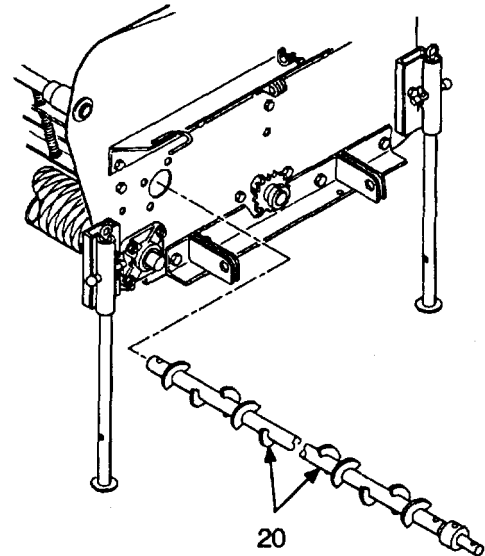

Note

Right-hand side of agitator pipe assembly has hole in end coupling for mounting sprocket; left-hand side does not. Ensure that you install the correct side of pipe assembly in the correct place.

- (19) Install right-hand side of agitator pipe assembly (20) through right side of spreader.

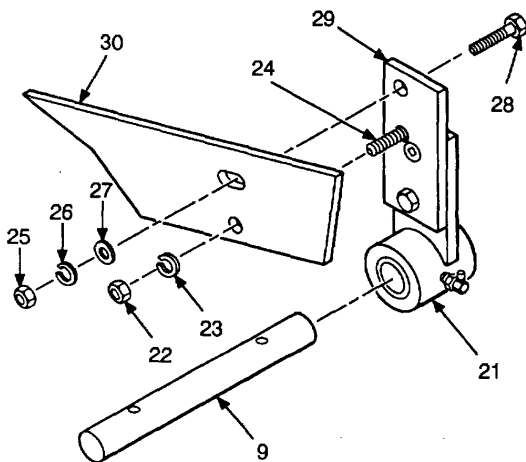

- (16) Inside hopper, install bearing hanger (29) on center gusset (30) using screw (28), flatwasher (27), new lockwasher (26), and nut (25). Do not fully tighten mounting hardware at this time.
- (17) Install new lockwasher (23) and nut (22) on square neck bolt (24) to secure bearing hanger (29) to center gusset (30). Do not fully tighten at this time.
- (18) Install bushing (9) in center bearing (21).

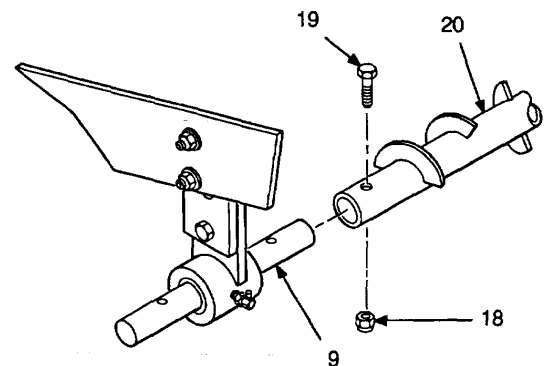

- (20) Inside hopper, secure right side of agitator pipe assembly (20) to bushing (9) using screw (19) and new locknut (18).

5-4. AGITATOR REPAIR (CONT).

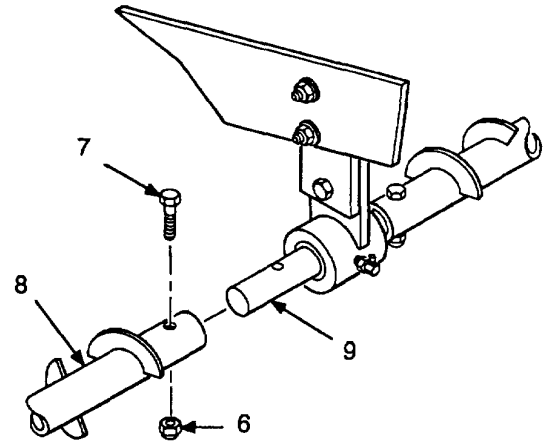
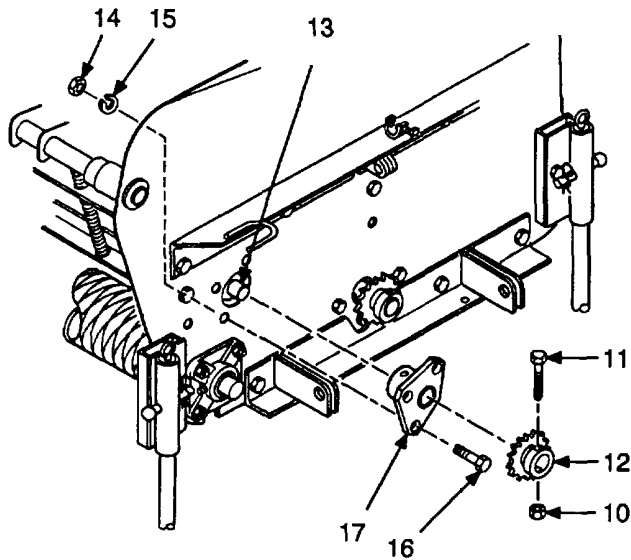

- (21) Install bushing (17) on right side of spreader using three screws (16), new lockwashers (15), and nuts (14). Tighten bushing mounting screws to 60 lb-ft.
- (22) Install sprocket (12) on end pin (13) using screw (11) and nut (10). Tighten sprocket mounting screw to 25 lb-ft.

- (24) Inside hopper, secure left side of agitator pipe assembly (8) to bushing (9) using screw (7) and new locknut (6).

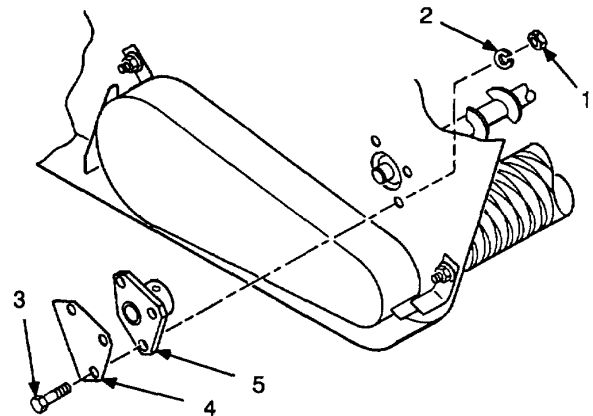
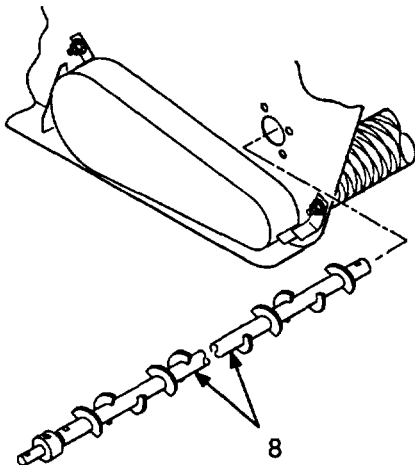

- (23) Install left-hand side of agitator pipe assembly (8) through left side of spreader.

- (25) Install bushing (5) and cover plate (4) on left side of spreader using three screws (3), new lockwashers (2), and nuts (1). Tighten cover plate mounting screws to 60 lb-ft.

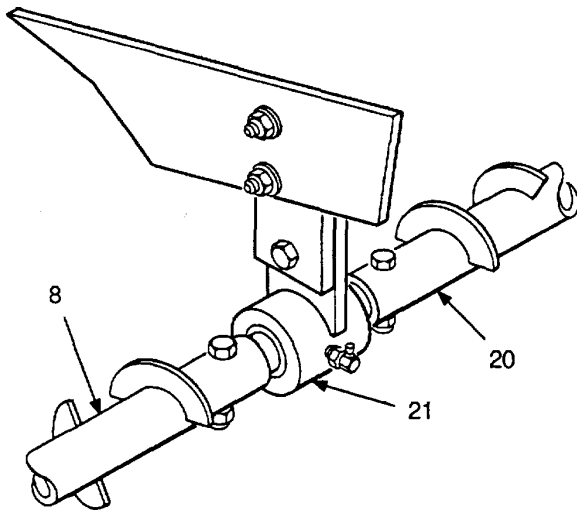

(26) Inside hopper, adjust position of center bearing (21) so that agitator pipes (8 and 20) will not scrape inside of hopper, then fully tighten all mounting hardware to 60 lb-ft.

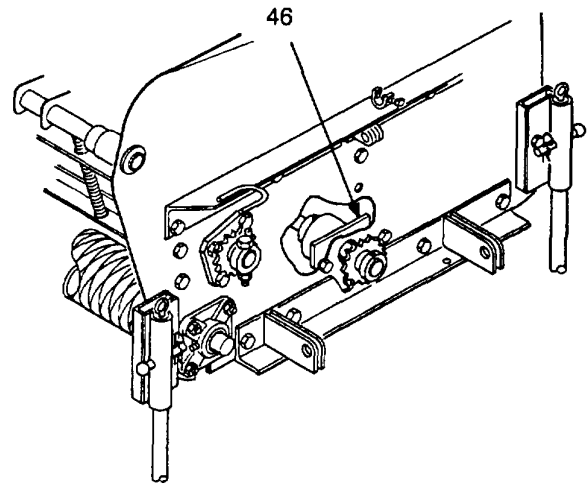

(27) Install agitator drive chain (para 4-38). Before installing chain guard, adjust position of bearing (46) to put tension on chain, then fully tighten bearing mounting hardware to 60 lb-ft. Install chain guard.

FOLLOW-ON MAINTENANCE:

- Lubricate agitator bearings and clutch (Chapter 3, Section I).
- Stow operator's platform in hopper (para 4-14).

5-5. FEED ROLL REPLACEMENT.

This task covers:

a. Removal

b. Installation

INITIAL SETUP

Tools:

Shop Equipment, Automotive Maintenance and Repair: Field Maintenance, Basic, Less Power

Materials/Parts:

One locknut
Eight lockwashers

Personnel Required: Three

Equipment Conditions:

Reference

- Para 4-18 Rear bracket removed from transport truck.
- Para 4-39 Feed roll drive chain removed.
- Para 4-40 Balance roller removed.

5-5. FEED ROLL REPLACEMENT (CONT).

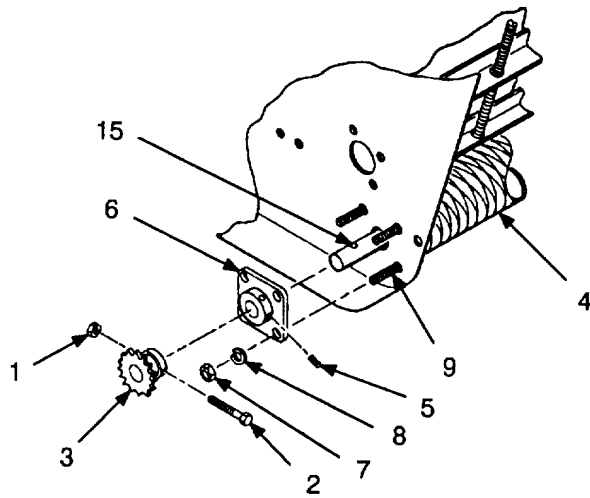

a. Removal.

- (1) Remove nut (1) and screw (2) securing sprocket (3) to left side of feed roll (4). Remove sprocket.
- (2) Loosen two setscrews (5) in bearing (6).
- (3) Remove four nuts (7) and lockwashers (8) securing bearing (6) to square neck bolts (9). Remove bearing. Discard lockwashers.

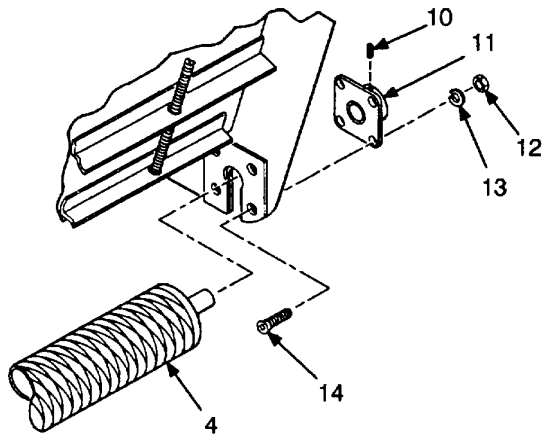

- (4) On right side of spreader, loosen two setscrews (10) in bearing (11).

WARNING

Feed roll is heavy (approx. 152 lb). Three people are required to lift feed roll. Failure to follow this warning could result in personnel injury.

- (5) Support feed roll (4). Remove four nuts (12) and lockwashers (13) securing bearing (11) to square neck bolts (14). Remove bearing. Lower feed roll and remove to right. Discard lockwashers.
- (6) Remove eight square neck bolts (9 and 14) from spreader.

b. Installation.

- (1) Install eight square neck bolts (9 and 14).

WARNING

Feed roll is heavy (approx. 152 lb). Three people are required to lift feed roll. Failure to follow this warning could result in personnel injury.

- (2) Install feed roll (4) from right and support in position. Ensure that hole (15) for screw (2) is on left side.
- (3) Install bearing (11) on right side of spreader using four nuts (12) and new lockwashers (13). Tighten bearing mounting nuts to 60 lb-ft.
- (4) Tighten two setscrews (10) in bearing (11).
- (5) Install bearing (6) on left side of spreader using four nuts (7) and new lockwashers (8). Tighten bearing mounting nuts to 60 lb-ft.
- (6) Tighten two setscrews (5) in bearing (6).
- (7) Install sprocket (3) on feed roll (4) using screw (2) and nut (1). Tighten sprocket mounting screw to 31 lb-ft.

FOLLOW-ON MAINTENANCE:

- Install rear bracket on transport truck (para 4-18).
- Install balance roller (para 4-40).
- Install feed roll drive chain (para 4-39).
- Lubricate feed roll bearings (Chapter 3, Section I).

**APPENDIX A
REFERENCES**

A-1. SCOPE

This appendix lists forms, field manuals, technical manuals, and other publications either referenced in this manual or which apply to the operation and maintenance of the Spreader.

A-2. DEPARTMENT OF THE ARMY PAMPHLETS

Consolidated Index of Army Publications and Blank Forms.....	DA Pam 25-30
Using Unit Supply System (Manual Procedures)	DA Pam 710-2-1
The Army Maintenance Management System (TAMMS).....	DA Pam 738-750

A-3. FORMS

Recommended Changes to Publications and Blank Forms.....	DA Form 2028
Recommended Changes to Equipment Technical Publications	DA Form 2028-2
Organizational Control Record for Equipment.....	DA Form 2401
Equipment Inspection and Maintenance Worksheet.....	DA Form 2404
Maintenance Request.....	DA Form 2407
Preventive Maintenance Schedule and Record	DD Form 314
Product Quality Deficiency Report (NSN 7540-00-105-0078).....	SF 368

A-4. FIELD MANUALS

NBC Contamination Avoidance.....	FM 3-3
NBC Protection.....	FM 3-4
NBC Decontamination.....	FM 3-5
NBC Handbook	FM 3-7
Camouflage	FM 5-20
Operation and Maintenance of Ordnance Materiel in Extreme Cold Weather (0 Deg. to Minus 65 Deg. F)	FM 9-207
Vehicle Recovery Operations.....	FM 20-22
First Aid for Soldiers	FM 21-11
Basic Cold Weather Manual.....	FM 31-70
Northern Operations.....	FM 31-71
Army Motor Transport Units and Operators	FM 55-30
Desert Operations (How to Fight).....	FM 90-3
Operational Symbols	FM 101-5-1

A-5. SUPPLY BULLETIN

Storage Serviceability Standard - Tracked Vehicles, Wheeled Vehicles, and Component Parts.....	SB 740-98-1
---	-------------

A-6. TECHNICAL BULLETINS

Equipment Improvement Report and Maintenance Digest
 (US Army Tank-Automotive Command) Tank-Automotive Equipment TB 43-0001-39-
 Series
 Color, Marking, and Camouflage Painting of Military Vehicles,
 Construction Equipment, and Materiel Handling Equipment TB 43-0209
 Maintenance in the Desert..... TB 43-0239
 Description, Use, Bonding Techniques, and Properties of Adhesives TB ORD 1032

A-7. TECHNICAL MANUALS

Inspection, Care, and Maintenance of Antifriction Bearings..... TM 9-214
 Operator's Manual for Welding Theory and Application..... TM 9-237
 Deepwater Fording of Ordnance Materiel TM 9-238
 Materials Used for Cleaning, Preserving, Abrading, and Cementing
 Ordnance Materiel and Related Items Including Chemicals..... TM 9-247
 Organizational, Direct Support, and General Support Care, Maintenance,
 and Repair of Pneumatic Tires and Inner Tubes..... TM 9-2610-200-24
 Painting Instructions for Field Use..... TM 43-0139
 Procedures for Destruction of Tank-Automotive Equipment
 to Prevent Enemy Use..... TM 750-244-6

A-8. OTHER PUBLICATIONS

Army Logistics Readiness and Sustainability..... AR 700-138
 Packaging of Army Material for Storage and Shipment AR 746-1
 Expendable/Durable Items (Except Medical, Class V,
 Repair Parts, and Heraldic Items) CTA 50-970
 Abbreviations for Use on Drawings Specifications, Standards, and
 Technical Documents MILSTD-12

APPENDIX B
MAINTENANCE ALLOCATION CHART

Section I. INTRODUCTION

B-1. GENERAL.

a. This section provides a general explanation of all maintenance and repair functions authorized at the various maintenance levels.

b. The Maintenance Allocation Chart (MAC) in Section II designates overall authority and responsibility for the performance of maintenance functions on the identified end item or component. The application of the maintenance functions to the end item or component will be consistent with the capacities and capabilities of the designated maintenance levels.

c. Section III lists the tools and test equipment (both special tools and common tool sets) required for each maintenance function as referenced from Section II.

d. Section IV contains supplemental instructions and explanatory notes for a particular maintenance function.

B-2. MAINTENANCE FUNCTIONS.

Maintenance functions will be limited to and defined as follows:

a. *Inspect.* To determine the serviceability of an item by comparing its physical, mechanical, and/or electrical characteristics with established standards through examination (e.g., by sight, sound, or feel).

b. *Test.* To verify serviceability by measuring the mechanical, pneumatic, hydraulic, or electrical characteristics of an item and comparing those characteristics with prescribed standards.

c. *Service.* Operations required periodically to keep an item in proper operating condition, i.e., to clean (includes decontaminate, when required), to preserve, to drain, to paint, or to replenish fuel, lubricants, chemical fluids, or gases.

d. *Adjust.* To maintain or regulate, within prescribed limits, by bringing into proper or exact position, or by setting the operating characteristics to specified parameters.

e. *Aline.* To adjust specified variable elements of an item to bring about optimum or desired performance.

f. *Calibrate.* To determine and cause corrections to be made or to be adjusted on Instruments or test, measuring, and diagnostic equipment used in precision measurement. Consists of comparisons of two instruments, one of which is a certified standard of known accuracy, to detect and adjust any discrepancy in the accuracy of the instrument being compared.

g. *Remove/Install.* To remove and install the same item when required to perform service or other maintenance functions. Install may be the act of emplacing, seating, or fixing into position a spare, repair part, or module (component or assembly) in a manner to allow the proper functioning of an equipment or system.

h. *Replace.* To remove an unserviceable item and Install a serviceable counterpart in its place. "Replace" is authorized by the MAC and is shown as the third position of the SMR code.

i. *Repair.* The application of maintenance services, including fault location/troubleshooting, removal/ installation, and disassembly/assembly procedures, and maintenance actions to identify troubles and restore serviceability to an item by correcting specific damage, fault, malfunction, or failure in a part, subassembly, module (component or assembly), end item, or system.

j. *Overhaul.* That maintenance effort (service/action) prescribed to restore an item to a completely serviceable/operational condition as required by maintenance standards in appropriate technical publications (i.e., DMWR). Overhaul is normally the highest degree of maintenance performed by the Army. Overhaul does not normally return an item to like new condition.

k. *Rebuild.* Consists of those services/actions necessary for the restoration of unserviceable equipment to a like new condition in accordance with original manufacturing standards. Rebuild is the highest degree of materiel maintenance applied to Army equipment. The rebuild operation includes the act of returning to zero those age measurements (hours/miles, etc.) considered in classifying Army equipment/ components.

B-3. EXPLANATION OF COLUMNS IN THE MAC, SECTION II.

a. *Column 1, Group Number.* Column 1 lists functional group code numbers, the purpose of which is to identify maintenance significant components, assemblies, subassemblies, and modules with the next higher assembly. End item group number shall be "00."

b. *Column 2, Component/Assembly.* Column 2 contains the names of components, assemblies, subassemblies, and modules for which maintenance is authorized.

c. *Column 3, Maintenance Function.* Column 3 lists the functions to be performed on the item listed in Column 2. (For a detailed explanation of these functions, refer to paragraph B-2.)

d. *Column 4, Maintenance Level.* Column 4 specifies, by the listing of a work time figure in the appropriate subcolumn(s), the level of maintenance authorized to perform the function listed in Column 3. This figure represents the active time required to perform that maintenance function at the indicated level of maintenance. If the number or complexity of the tasks within the listed maintenance function vary at different maintenance levels, appropriate work time figures will be shown for each level. The work time figure represents the average time required to restore an item (assembly, subassembly, component, module, end item, or system) to a serviceable condition under typical field operating conditions. This time includes preparation time (including any necessary disassembly/assembly time), troubleshooting/fault location time, and quality assurance/quality control time in addition to the time required to perform the specific tasks identified for the maintenance functions authorized in the MAC. The symbol designations for the various maintenance levels are as follows:

- C Unit (Operator or Crew)
- O Unit Maintenance
- F Direct Support Maintenance
- H General Support Maintenance
- D Depot Maintenance

e. *Column 5, Tools and Equipment.* Column 5 specifies, by code, those common tool sets (not individual tools) and special tools, TMDE, and support equipment required to perform the designated function.

f. *Column 6, Remarks.* This column shall, when applicable, contain a letter code, in alphabetic order, which shall be keyed to the remarks contained in Section IV.

B-4. EXPLANATION OF COLUMNS IN TOOL AND TEST EQUIPMENT REQUIREMENTS, SECTION III.

a. *Column 1, Tool or Test Equipment Reference Code.* The tool and test equipment reference code correlates with a code used in the MAC, Section II, Column 5.

b. *Column 2, Maintenance Level.* The lowest level of maintenance authorized to use the tool or test equipment.

c. *Column 3, Nomenclature.* Name or identification of the tool or test equipment.

d. *Column 4, National/NATO Stock Number.* The National or NATO Stock Number of the tool or test equipment.

e. *Column 5, Tool Number.* The manufacturer's part number.

B-5. EXPLANATION OF COLUMNS IN REMARKS, SECTION IV.

a. *Column 1, Reference Code.* The code recorded in Column 6, Section II.

b. *Column 2, Remarks.* This column lists information pertinent to the maintenance function being performed as indicated in the MAC, Section II.

Section II. MAINTENANCE ALLOCATION CHART

(1) GROUP NUMBER	(2) COMPONENT ASSEMBLY	(3) MAINTENANCE FUNCTION	(4) MAINTENANCE LEVEL					(5) TOOLS AND EQUIPMENT	(6) REMARKS
			UNIT		DS	GS	Depot		
			C	O	F	H	D		
00	AGGREGATE SPREADER								
06	ELECTRICAL SYSTEM								
0609	Lights	Inspect Replace Repair	0.1	0.1 0.4				1 1	
0613	Hull or chassis wiring harness	Inspect Replace Repair	0.1	0.4 0.5				1,2 1,2	
11	REAR AXLE								
1100	Rear axle assembly Transport axle, right side/left side	Replace		2.8				1,2	
13	WHEELS AND TRACKS								
1311	Wheel assembly Hub assembly	Replace Inspect Service Replace Repair		0.2 0.1 1.0 0.5 0.3				1,2 1,2 1,2 1,2	
1313	Tires, tubes, tire chains Tires	Inspect Replace Repair	0.1	1.0 0.1	1.0			1,2 1,3	
	Tubes	Replace Repair		1.0 2.0				1,2 1,2 A	
15	FRAME, TOWING ATTACHMENTS, DRAWBARS, AND ARTICULATION SYSTEMS								
1501	Frame assembly Operator platform	Inspect Replace Repair	0.1	1.0 0.6				1 1,2	

Section II. MAINTENANCE ALLOCATION CHART (Cont.)

(1) GROUP NUMBER	(2) COMPONENT ASSEMBLY	(3) MAINTENANCE FUNCTION	(4) MAINTENANCE LEVEL					(5) TOOLS AND EQUIPMENT	(6) REMARKS	
			UNIT		DS	GS	Depot			
			C	O	F	H	D			
1503	<i>Pintles and towing attachments</i>	Transport tongue	Inspect	0.1						
			Replace		0.6				1,2	
		Truck hitch	Inspect	0.1						
			Replace		0.9				1,2	
		Coupler hitch and crank assembly	Inspect	0.1	0.2					
			Service		0.4					
1507	<i>Landing gear, leveling jacks</i>	Replace			1.3			3		
		Repair			1.9			3		
		Replace		0.4				1		
		Repair		0.5				1		
		22 BODY, CHASSIS, AND HULL ACCESSORY ITEMS								
		2202	<i>Accessory items</i>	Reflectors			0.2			1
Toolbox					0.2			1		
2210	<i>Data plates and instruction holders</i>	Data plates			0.4			1,2		
73 CONCRETE AND ASPHALT EQUIPMENT COMPONENTS										
7303	<i>Controls</i>	Feed roll control lever	Inspect	0.1	0.1					
			Replace		0.3			1		
		Clutch shift arm	Inspect		0.1					
			Replace		0.7			1		
			Repair		0.2			1		
		Gate control lever	Inspect	0.1	0.2					
			Replace		0.6			1		
		Gate adjustment screw	Inspect	0.1	0.2					
		Replace		0.8			1			

(1) GROUP NUMBER	(2) COMPONENT ASSEMBLY	(3) MAINTENANCE FUNCTION	(4) MAINTENANCE LEVEL					(5) TOOLS AND EQUIPMENT	(6) REMARKS	
			UNIT		DS	GS	Depot			
			C	O	F	H	D			
7304	<i>Hoppers, gates, and chutes</i> Hopper assembly	Inspect		0.5					1,2	B
		Repair		5.6						
7305	<i>Main drive</i> Gearbox	Inspect	0.1	0.2					1	
		Service		0.5					1,2	
		Replace		2.0					3	
7309	<i>Vane or screw feeders or conveyors</i> Agitator assembly	Repair			1.6					
		Inspect		0.2						
		Service		0.5						
		Replace			2.1				3	
7311	<i>Feeding or conveyor shaft</i> Feed roll	Repair			0.5				3	
		Inspect	0.1	0.2						
		Service		0.2					1	
7315	<i>Traction drive</i> Wheel assembly	Replace		0.2					1	
		Inspect		0.2					1,2	
		Replace		0.4					1,2	
		Repair		0.5						
7315	<i>Traction drive</i> Wheel assembly	Inspect	0.2							
		Service		0.5						
		Replace		5.0					1,2	
		Repair		1.3				1,2		

Section III. TOOL AND TEST EQUIPMENT REQUIREMENTS

(1) TOOL OR TEST EQUIPMENT TOOL REF CODE	(2) MAINTENANCE LEVEL	(3) NOMENCLATURE	(4) STOCK NUMBER	(5) NATIONAL/NATO NUMBER
1	O	Tool kit, general mechanic's automotive	5180-001 77-7033	SC 5180-90-CL-N26
2	O	Shop equipment, automotive maintenance and repair, organizational maintenance, common no. 1	4910-00-754-0654	SC 4910-95-CL-A74
3	F	Shop equipment, automotive maintenance and repair: field maintenance, basic, less power	4910-00-754-0705	SC 4910-95-A31

Section IV. REMARKS

(1) Reference Code	(2) Remarks
A	Organizational level maintenance (O) is authorized to repair tires with plugs. Refer to TM 9-2610-200-14 for tire and tube repair.
B	Hopper repair limited to replacement of belting, gate adjusting pipe and bearings, balance levers, gate and brackets, and attaching hardware.

APPENDIX C

COMPONENTS OF END ITEM AND BASIC ISSUE ITEMS LISTS

Section I. INTRODUCTION

C-1. SCOPE.

This appendix lists components of end item and basic issue items for the spreader to help you inventory items required for safe and efficient operation.

C-2. GENERAL

The Components of End Item and Basic Issue Items Lists are divided into the following sections:

a. Section II. Components of End Item. This listing is for informational purposes only, and is not authority to requisition replacements. These items are part of the end item, but are removed and separately packaged for transportation or shipment. As part of the end item, these items must be with the end item whenever it is issued or transferred between property accounts. Illustrations are furnished to assist you in identifying the items.

b. Section III. Basic Issue Items. These are the minimum essential items required to place the spreader in operation, to operate it, and to perform emergency repairs. Although shipped separately packaged, BII must be with the spreader during operation and whenever it is transferred between property accounts. The illustrations will assist you with hard-to-identify items. This manual is

your authority to request/requisition replacement BII, based on TOE/MTOE authorization of the end item.

C-3. EXPLANATION OF COLUMNS.

The following provides an explanation of columns found in the tabular listings:

a. Column (1)-Illustration Number (Illus. Number). This column indicates the number of the illustration in which the item is shown.

b. Column (2) -National Stock Number. This column indicates the National stock number assigned to the item and will be used for requisitioning purposes.

c. Column (3) Description. Indicates the Federal item name and, if required, a minimum description to identify and locate the item. The last line for each item indicates the CAGEC (in parentheses) followed by the part number.

d. Column (4) Unit of Measure (U/M). Indicates the measure used in performing the actual operational/maintenance function. The measure is expressed by a two-character alphabetical abbreviation (e.g., ea, in, pr).

e. Column (5) Quantity Required (Qty Rqr). Indicates the quantity of the item authorized to be used with/on the equipment.

Section II. COMPONENTS OF END ITEM

Not applicable.

Section III. BASIC ISSUE ITEMS

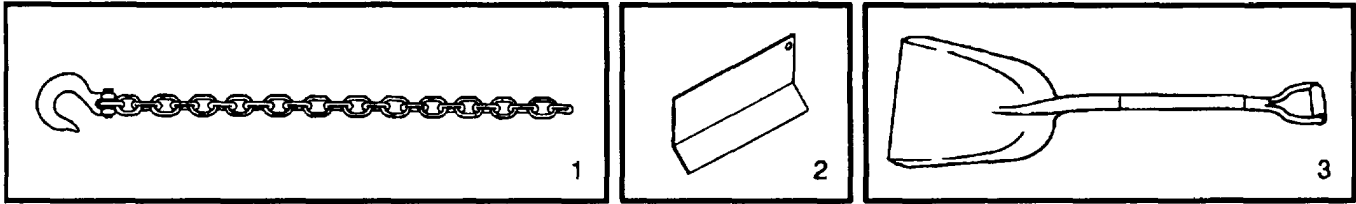

(1) Illus. Number	(2) NATIONAL STOCK NUMBER	(3) Description Usable on CAGEC and Part Number	(4) Qty Code	(5) U/M Req'd.
1	5120-00-188-8446	Chain, tailgate to hopper (09780) 24264-BS3	ea.	2
2		Insert (09780) 10760-A	ea.	4
3		Scoop, eastern pattern (81348) GGG-S-326	ea.	1

**APPENDIX D
ADDITIONAL AUTHORIZATION LIST**

Section I. INTRODUCTION

D-1. SCOPE.

This appendix lists additional items you are authorized for support of the spreader.

D-2. GENERAL.

This list identifies items that do not have to accompany the spreader and that do not have to be turned in with it.

These items are authorized to you by CTA, MTOE, TDA, or JTA.

D-3. EXPLANATION OF LISTING.

National stock numbers, descriptions, and quantities are provided to help you identify and request the additional items you require to support the equipment.

Section II. ADDITIONAL AUTHORIZATION LIST

(1)		(2)			(3)	(4)
NATIONAL STOCK NUMBER	Description CAGEC	and Part Number Code	Usable on U/M	Qty Auth.		
2540-00-678-3469	Chock, wheel-track (96906)			MS52127-3	ea.	2

D-1 / D-2 (blank)

APPENDIX E

EXPENDABLE/DURABLE SUPPLIES AND MATERIALS LIST

Section I. INTRODUCTION

E-1. SCOPE.

This appendix lists expendable supplies and materials you will need to operate and maintain the aggregate spreader. This listing is for information purposes only and is not authority to requisition the listed items. These items are authorized to you by CTA 50-970, Expendable/Durable Items (Except Medical, Class V, Repair Parts, and Heraldic Items) or CTA 8-100, Army Medical Department Expendable/Durable Items.

C -- Operator
 O -- Organizational Maintenance
 F -- Direct Support Maintenance
 H -- General Support Maintenance

c. Column (3)-National Stock Number. This is the National stock number assigned to the item. Use it to request or requisition the item.

d. Column (4)-Description. Indicates the Federal item name and, if required, a description to identify the item. The last line for each item indicates the Commercial and Government Entity (CAGE) code in parentheses followed by the part number.

e. Column (5) -Unit of Measure (U/M). Indicates the measure used in performing the actual maintenance function. This measure is expressed by a two-character alphabetical abbreviation (e.g., ea., in, pr). If the unit of measure differs from the unit of issue, requisition the lowest unit of issue that will satisfy your requirements.

E-2. EXPLANATION OF COLUMNS.

a. Column (1)-Item Number. This number is assigned to the entry in the listing and is reference in the narrative instructions to identify the material needed (e.g., Dry cleaning solvent, Item 11, Appendix E).

b. Column (2)-Level. This column identifies the lowest level of maintenance that requires the listed item.

Section II. EXPENDABLE/DURABLE SUPPLIES AND MATERIALS LIST

(1) ITEM NUMBER	(2) LEVEL	(3) NATIONAL STOCK NUMBER	(4) DESCRIPTION (CAGE) PART NUMBER	(5) UNIT OF MEAS
1	O	8135-00-171-0930	Barrier material, greaseproofed-waterproofed, flexible (81349) MIL-B-121 100-yd roll	yd
2	C	7930-00-282-9699	Detergent, general purpose, liquid (81349) MIL-D-16791 1 gal. can	gl
3	O	9150-01-197-7693 9150-01-197-7690 9150-01-197-7689 9150-01-197-7692	Grease, automotive and artillery (81349) MIL-G-10924 14 oz cartridge 1.75 lb can 6.5 lb can 35 lb pail	oz lb lb lb
4	O	9150-01-035-5392 915001-035-5393 9150-01-035-5394	Lubricating oil, gear, GO-80/90 (81349) MIL-L-2105 1 qt can 5 gal. can 55 gal. drum	qt gl gl
5	O	9150-01-035-5390 9150-01-048-4593 9150-01-035-5391	Lubricating oil, gear, GO-75 (81349) MIL-L-2105 1 qt can 1 gal. can 5 gal. can	qt gl gl
6	O	9150-01-177-3988 9150-00-189-6727 9150-00-186-6668 9150-00-191-2772	Oil, lubricating, OE/HDO-10 (81349) MIL-L-2104 1 qt HDPE (plastic) 1 qt can 5 gal. can 55 gal. drum	qt qt gl gl
7	O	9150-00-402-4478 9150-00-402-2372 9150-00-491-7197	Oil, lubricating, OEA (81349) MIL-L-46167 1 qt can 5 gal. can 55 gal. drum	qt gl gl

(1) ITEM NUMBER	(2) LEVEL	(3) NATIONAL STOCK NUMBER	(4) DESCRIPTION (CAGE) PART NUMBER	(5) UNIT OF MEAS
8	O	5350-01-240-8401	Paper, abrasive (61585) OFTI 9 600 grit	ea
9	C	7920-00-205-1711	Rag, wiping (58536) A-A-531 50 lb bale	lb
10	O	3439-00-265-7102	Solder, lead alloy (81348) QQ-5-571 1 lb roll	lb
11	C	6850-00-664-5685 6850-00-274-5421 6850-00-285-8011	Solvent, dry cleaning (81348) P-D-680, Type II 1 qt can 5 gal. can 55 gal. drum	qt gal gal
12	C	5975-00-133-8696	Strap, tiedown, electrical component (96906) MS3367-6-9 100 each	ea
13	O	9905-00-537-8954	Tag, marker (81349) MIL-T-12755 50 each	ea
14	O	5970-00-198-8621	Tape, insulation, electricians (81348) HH1510	ft

**APPENDIX F
REPAIR PARTS AND SPECIAL TOOLS LIST**

Section I. INTRODUCTION

in alphanumeric sequence and cross-references NSN, CAGEC, and part number.

F-3. EXPLANATION OF COLUMNS (SECTIONS II AND III).

a. *Item No. (Column (1)).* Indicates the number used to identify items called out in the illustration.

b. *SMR Code (Column (2)).* The source, maintenance, and recoverability code is a 5-position code containing supply/requisitioning information, maintenance category authorization criteria, and disposition instruction, as shown in the following breakout::

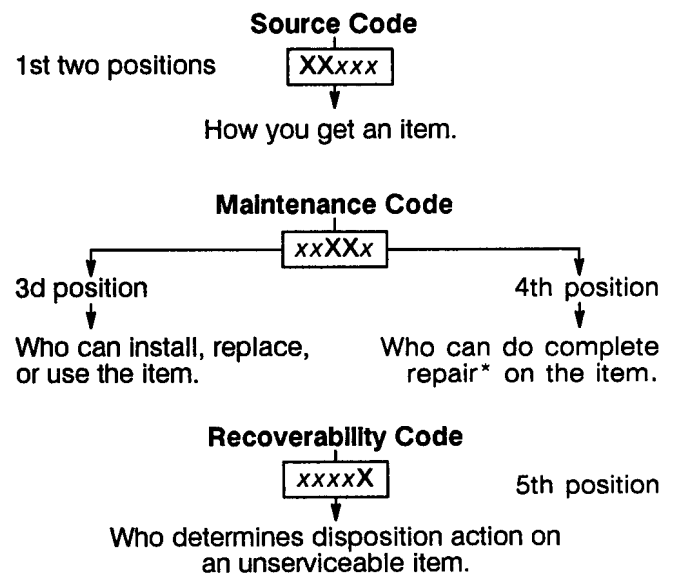

* *Complete repair.* Maintenance capacity, capability, and authority to perform all corrective maintenance tasks of the "repair" function in a use/user environment in order to restore serviceability to a failed item.

- (1) Source Code. The source code tells you how to get an item needed for maintenance, repair, or overhaul of an end item/equipment. Explanation of source codes follows:

F-1. SCOPE.

This RPSTL lists and authorizes spares and repair parts; special tools; special test, measurement, and diagnostic equipment (TMDE); and other special support equipment required for performance of unit, direct support, and general support maintenance on the aggregate spreader. It authorizes the requisitioning, issue, and disposition of spares, repair parts, and special tools as indicated by the source, maintenance, and recoverability (SMR) codes.

F-2. GENERAL.

In addition to Section I, Introduction, this RPSTL is divided into the following sections.

a. *Section 11-Repair Parts List.* A list of spares and repair parts authorized by this RPSTL for use in the performance of maintenance. The list also includes parts that must be removed for replacement of the authorized parts. Parts lists are composed of functional groups in ascending figure and item number sequence. Bulk materials are listed by item name in FIG BULK at the end of the section. Repair parts kits or sets are listed separately in their own functional group within Section II. Repair parts for repairable special tools are also listed in the section.

b. *Section III-Special Tools List.* A list of special tools, special TMDE, and other special support equipment authorized by this RPSTL (as indicated by Basis of Issue (BOI) information in DESCRIPTION AND USABLE ON CODE (UOC) column) for the performance of maintenance.

c. *Section IV-Cross-reference Indexes.* A list, in national item identification number (NIIN) sequence, of all national stock numbered items appearing in the listings, followed by a list in alphanumeric sequence of all part numbers appearing in the listings. National stock numbers and part numbers are cross-referenced to each illustration figure and item number appearance. The figure and item number index lists figure and item number

F-3. EXPLANATION OF COLUMNS (SECTIONS II AND III) (CONT).

<u>Code</u>	<u>Application/Explanation</u>
PA PB PC PD PE PF PG	Stocked items; use the applicable NSN to request/requisition items with these source codes. They are authorized to the category indicated by the code entered in the 3d PE position of the SMR code. ** Items coded PC are subject to deterioration.

KD KF KB	Items with these codes are not to be requested/requisitioned individually. They are part of a kit which is authorized to the maintenance category indicated in the 3d position of the SMR code. The complete kit must be requisitioned and applied.
----------------	---

MO—Made at org/ AVUM category MF—Made at DS/ AVUM category MH—Made at GS category ML—Made at Specialized Repair Activity (SRA) MD—Made at Depot	Items with these codes are not to be requested/requisitioned individually. They must be made from bulk material which is identified by the part number in the DESCRIPTION AND USABLE ON CODE (UOC) column and listed in the Bulk Material group of the repair parts list in this RPSTL. If the item is authorized to you by the 3d position code of the SMR code, but the source code indicates it is made at a higher level, order the item from the higher level of maintenance.
---	--

AO—Assembled by org/AVUM category AF—Assembled by DS/AVUM category AH—Assembled by GS category AL—Assembled by SRA AD—Assembled by Depot	Items with these codes are not to be requested/requisitioned individually. The parts that make up the assembled item must be requisitioned or fabricated and assembled at the level of maintenance indicated by the source code. If the 3d position code of the SMR code authorizes you to replace the item, but the source code indicates the item is assembled at a higher level, order the item from the higher level of maintenance.
---	--

XA Do not requisition an "XA"-coded item. Order its next higher assembly. (Also refer to the NOTE following.)

XB If an "XB" item is not available from salvage, order it using the CAGE and part number given.

XC Installation drawing, diagram, instruction sheet, field service drawing, that is Identified by the manufacturer's part number.

XD Item is not stocked. Order an "XD"-coded item through normal supply channels using the CAGE and part number given, if no NSN is available.

NOTE

Cannibalization or controlled exchange, when authorized, may be used as a source of supply for items with the above source codes, except for those source coded XA or those aircraft support items restricted by requirements of AR 700-42.

(2) Maintenance Code. Maintenance codes tell you the level(s) of maintenance authorized to USE and REPAIR support items. The maintenance codes are entered in the third and fourth positions of the SMR code as follows:

(a) The maintenance code entered in the third position tells you the lowest maintenance level authorized to remove, replace, and use an item. The maintenance code entered in the third position will indicate authorization to one of the following levels of maintenance:

<u>Code</u>	<u>Application/Explanation</u>
C	Crew or operator maintenance done within unit maintenance or aviation unit maintenance.
O	Unit maintenance or aviation unit category can remove, replace, and use the item.
F	Direct support or aviation intermediate level can remove, replace, and use the item.
H	General support level can remove, replace, and use the item.
L	Specialized repair activity can remove, replace, and use the item.
D	Depot level can remove, replace, and use the item.

(b) The maintenance code entered in the fourth position tells whether or not the item is to be repaired and identifies the lowest maintenance level with the capability to do complete repair (i.e., perform all authorized repair functions). (NOTE: Some limited repair may be done on the item at a lower level of maintenance, if authorized by the maintenance allocation

chart (MAC) or SMR codes.) This position will contain one of the following maintenance codes:

<u>Code</u>	<u>Application/Explanation</u>
0	Unit maintenance or aviation unit is the lowest level that can do complete repair of the item.
F	Direct support or aviation intermediate is the lowest level than can do complete repair of the item.
H	General support is the lowest level that can do complete repair of the item.
L	Specialized repair activity is the lowest level that can do complete repair of the item.
D	Depot is the lowest level that can do complete repair of the item.
Z	Nonreparable. No repair is authorized.
B	No repair is authorized. (No parts or special tools are authorized for the maintenance of a "B"-coded item.) However, the item may be reconditioned by adjusting, lubricating, etc. at the user level.

- (3) Recoverability Code. Recoverability codes are assigned to items to indicate the disposition action on unserviceable items. The recoverability code is entered in the fifth position of the SMR code as follows:

<u>Code</u>	<u>Application/Explanation</u>
Z	Nonreparable item. When unserviceable, condemn and dispose of the item at the level of maintenance shown in the 3d position of the SMR code.
O	Reparable item. When uneconomically repairable, condemn and dispose of the item at unit maintenance or aviation unit level.
F	Reparable item. When uneconomically repairable, condemn and dispose of the item at the direct support or aviation intermediate level.
H	Reparable item. When uneconomically repairable, condemn and dispose of the item at the general support level.
D	Reparable item. When beyond lower level repair capability, return to depot. Condemnation and disposal of item not authorized below depot level.

- L Reparable item. Condemnation and disposal of item not authorized below specialized repair activity (SRA).
- A Item requires special handling or condemnation procedures because of specific reasons (e.g., precious metal content, high dollar value, critical material, or hazardous material). Refer to appropriate manuals/directives for specific instructions.

c. *CAGEC (Column (3))*. The commercial and government entity code (CAGEC) is a 5-digit numeric code used to identify the manufacturer, distributor, or government agency, etc. that supplies the item.

d. *Part Number (Column (4))*. Indicates the primary number used by the manufacturer (individual, company, firm, corporation, or government activity) that controls the design and characteristics of the item by means of its engineering drawings, specifications, standards, and Inspection requirements to identify an item or range of items.

NOTE

When you use an NSN to requisition an item, the item you receive may have a different part number from the part ordered.

e. *Description and Usable on Code (UOC) (Column (5))*. This column includes the following information:

- (1) The federal item name and, when required, a minimum description to identify the item.
- (2) Items that are included in kits and sets are listed below the name of the kit or set.
- (3) Spare/repair parts that make up an assembled item are listed immediately following the assembled item line entry.
- (4) Part number for bulk materials are referenced in this column in the line item entry for the item to be manufactured/fabricated.
- (5) When the item is not used with all serial numbers of the same model, the effective serial numbers are shown on the last line(s) of the description (before UOC).
- (6) The UOC, when applicable (see paragraph F-5, Special Information).
- (7) In the special tools list section, the basis of issue (BOI) appears as the last line(s) in the entry for each special tool, special TMDE, and other special support equipment. When density of equipment supported exceeds density spread indicated in the BOI, the total authorization is increased proportionately.

F-3. EXPLANATION OF COLUMNS (SECTIONS II AND III) (CONT).

- (8) The statement "END OF FIGURE" appears just below the last item description in Column 5 for a given figure in both Section II and Section III.

f. QTY (Column (6)). The QTY (quantity per figure column) indicates the quantity of the item used in the breakout shown on the illustration figure, which is prepared for a functional group, subfunctional group, or an assembly. A "V" appearing in this column in lieu of a quantity indicates that the quantity is variable and the quantity may vary from application to application.

F-4. EXPLANATION OF COLUMNS (SECTION IV).

a. National Stock Number (NSN) Index.

- (1) Stock Number Column. This column lists the NSN by national item identification number (NIIN) sequence. The NIIN consists of the last nine digits of the

NSN $\frac{NSN}{NIIN}$ (i.e., 5305-01-674-1467). When using this

column to locate an item, ignore the first 4 digits of the NSN. However, the complete NSN should be used when ordering items by stock number.

- (2) FIG Column. This column lists the number of the figure where the items is identified/located. The figures are in numerical order in Section II and Section III.
- (3) Item Column. The item number identifies the item associated with the figure listed in the adjacent FIG column. This item is also identified by the NSN listed on the same line.

b. Part Number Index. Part numbers in this index are listed by part number in ascending alphanumeric sequence (i.e., vertical arrangement of letter and number combination that places the first letter or digit of each group in order A through Z, followed by the numbers 0 through 9 and each following letter or digit in like order).

- (1) CAGE C Column. The commercial and government entity code (CAGEC) is a 5-digit numeric code used to identify the manufacturer, distributor, or government agency, etc. that supplies the item.

- (2) Part Number Column. Indicates the primary number used by the manufacturer (individual, firm, corporation, or government activity) that controls the design and characteristics of the item by means of its engineering drawings, specifications, standards, and inspection requirements to identify an item or range of items.
- (3) Stock Number Column. This column lists the NSN for the associated part number and manufacturer identified in the part number and CAGEC columns to the left.
- (4) FIG Column. This column lists the number of the figure where the item is identified/located in Section II or Section III.
- (5) Item Column. The item number is that number assigned to the item as it appears in the figure referenced in the adjacent figure number column.

c. Figure and item Number Index.

- (1) FIG Column. This column lists the number of the figure where the item is identified/located in Section II or Section III.
- (2) Item Column. The item number is that number assigned to the item as it appears in the figure referenced in the adjacent figure number column.
- (3) Stock Number Column. This column lists the NSN for the item.
- (4) CAGEC Column. The commercial and government entity code (CAGEC) is a 5digit numeric code used to identify the manufacturer, distributor, or government agency, etc. that supplies the item.
- (5) Part Number Column. Indicates the primary number used by the manufacturer (individual, firm, corporation, or government activity) that controls the design and characteristics of the item by means of its engineering drawing, specifications, standards, and inspection requirements to identify an item or range of items.

F-5. SPECIAL INFORMATION.

a Fabrication Instructions. Bulk materials required to manufacture items are listed in the Bulk Material Functional Group of this RPSTL. Part numbers for bulk materials are also referenced in the DESCRIPTION column of the line item entry for the item to be

manufactured/fabricated. Detailed fabrication instructions for items source coded to be manufactured or fabricated are found in Appendix G of this manual.

b. *Assembly Instructions.* Detailed assembly instructions for items source coded to be assembled from component spare/repair parts are found in Chapters 4 and 5. Items that make up the assembly are listed immediately following the assembly item entry or reference is made to an applicable figure.

c. *Kits.* Line item entries for repair parts kits appear in group 9401 in Section II.

IF-6. HOW TO LOCATE REPAIR PARTS.

a. *When National Stock Number or Part Number Is Not Known:*

- (1) First. Using the Table of Contents, determine the assembly group to which the item belongs. This is necessary since figures are prepared for assembly groups and subassembly groups, and listings are divided into the same groups.
- (2) Second. Find the figure covering the assembly group or subassembly group to which the item belongs.

- (3) Third. Identify the item on the figure and use the Figure and Item Number Index to find the NSN.

b. *When National Stock Number or Part Number is Known:*

- (1) First. Using the National Stock Number Index or the Part Number Index, find the pertinent NSN or part number. The NSN index is in NIIN sequence (see paragraph F-4a(1)). The part numbers in the Part Number Index are listed in ascending alphanumeric sequence (see paragraph F-4b). Both indexes cross-reference you to the illustration/figure and item number of the item you are looking for.
- (2) Second. Turn to the figure and item number, verify that the item is the one you're looking for, then locate the item number in the repair parts list for the figure.

IF-7. ABBREVIATIONS.

For standard abbreviations, see MIL-STD-12, Military Standard Abbreviations for Use on Drawings, Specifications, Standards, and in Technical Documents.

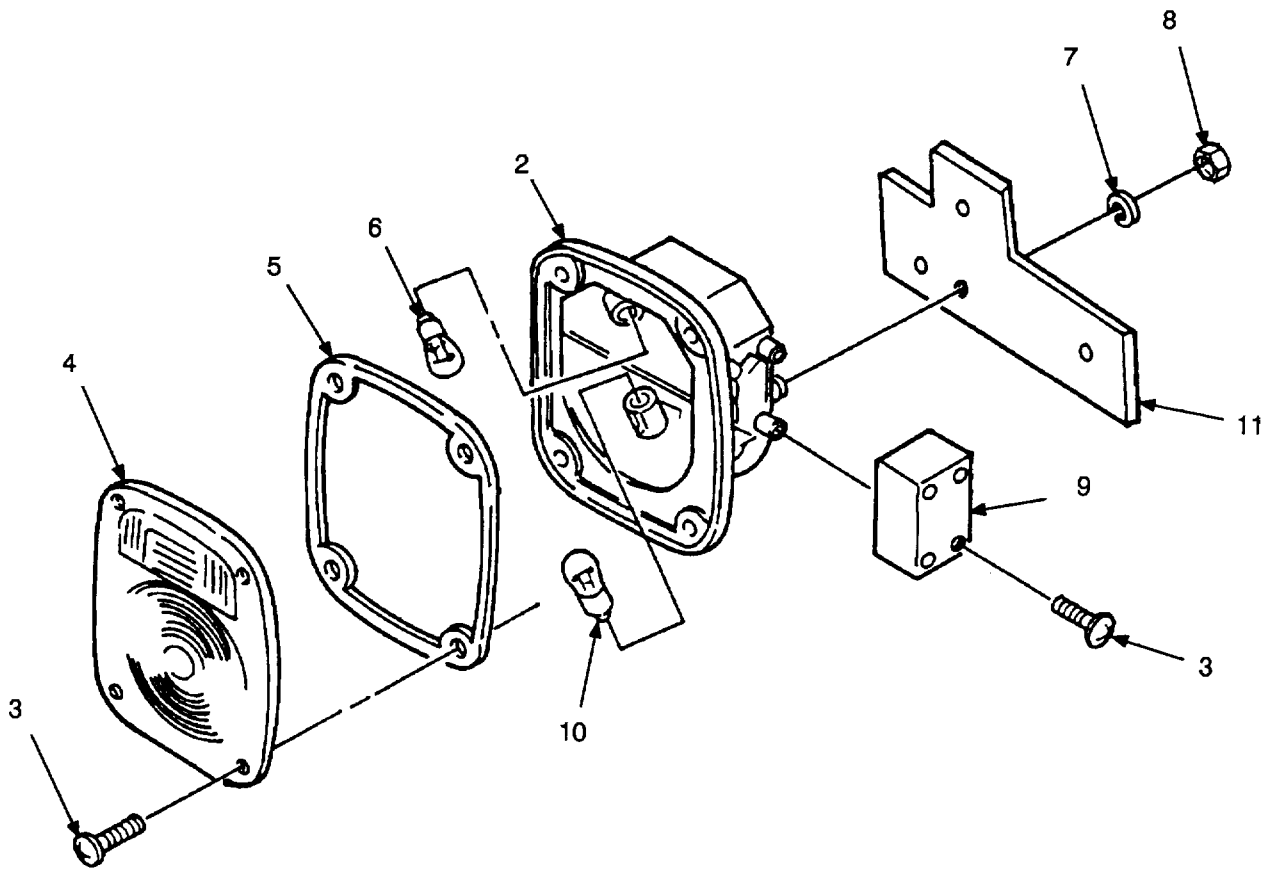
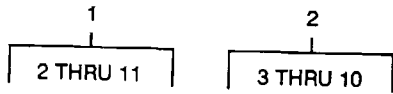

FIGURE 1. TAILLIGHT ASSEMBLY

SECTION II

TM 5-3895-367-14&P

(1) ITEM NO	(2) SMR CODE	(3) CAGEC	(4) PART NUMBER	(5) DESCRIPTION AND USABLE ON CODE (UOC)	(6) QTY
GROUP 06 ELECTRICAL SYSTEM					
GROUP 0609 LIGHTS					
FIG, 1 TAILLIGHT ASSEMBLY					
1	PAOOO	09780	SA-24220-B-2	STOP LIGHT-TAILLIGH RIGHT HAND	1
1	PAOOO	09780	SA-24220-B-3	STOP LIGHT-TAILLIGH LEFT HAND	1
2	PAOOO	81834	50942	..STOP LIGHT-TAILLIGH RIGHT HAND	1
2	PAOOO	81834	50952	..STOP LIGHT-TAILLIGH LEFT HAND	1
3	PAOZZ	81834	23-0133-35	..SCREW,TAPPING	8
4	PAOZZ	81834	91302	..LENS,LIGHT	1
5	PAOZZ	81834	61-2C37-03	..GASKET.....	1
6	PAOZZ	09780	24273	..LAMP, INCANDESCENT 24V DOUBLE.....	1
ELEMENT					
7	PAOZZ	96906	MS45904-68	..WASHER, LOCK	3
8	PAOZZ	96906	MS51967-2	..NUT,PLAIN,HEXAGCN.....	3
9	PAOZZ	81834	10-7056-01	..COVER, JUNCTION BOX.	1
10	PAOZZ	10988	L32257	..LAMP, INCANOESCENT	1
11	PFOZZ	09780	24272-8	..BRACKET, MOUNTING	1

END OF FIGLPE

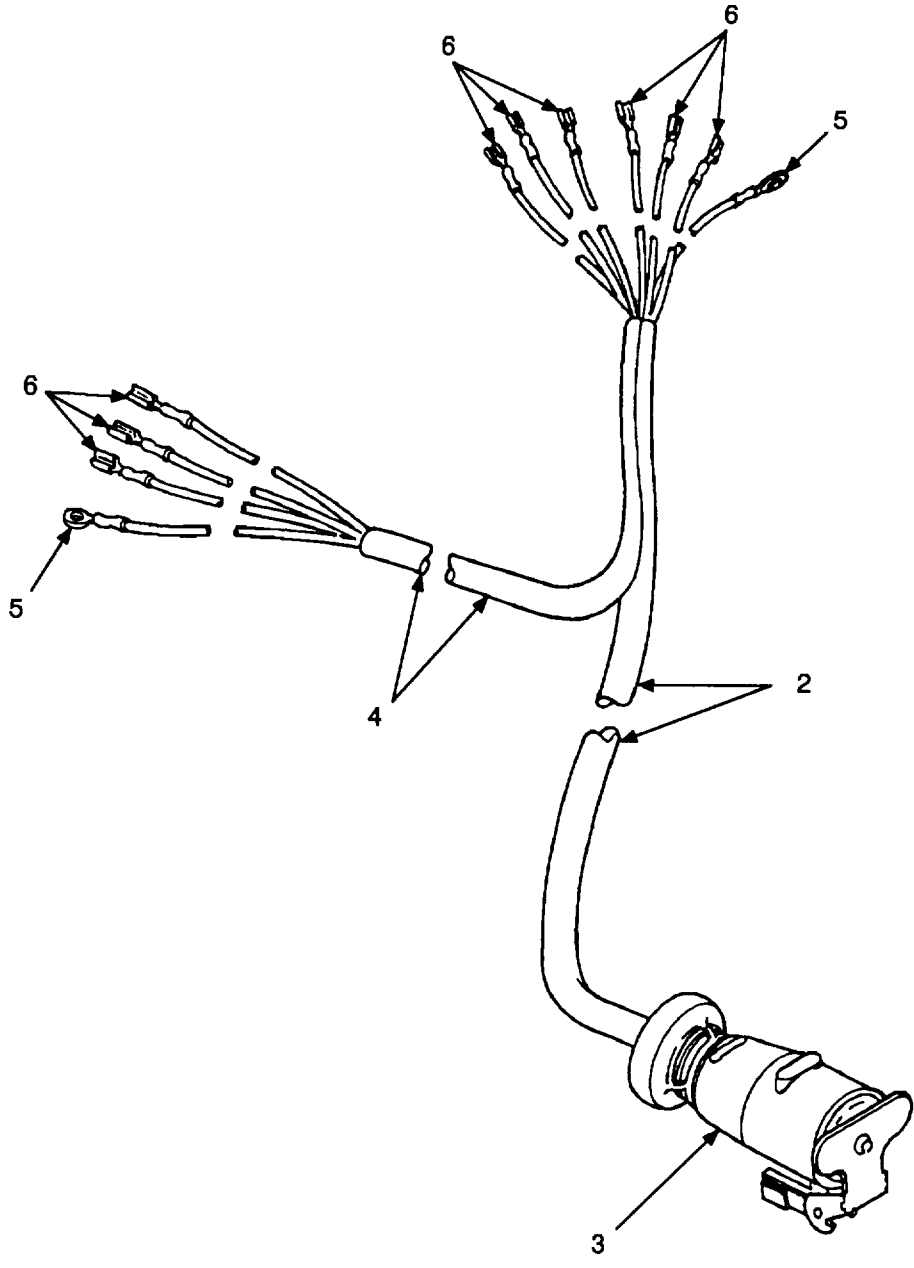
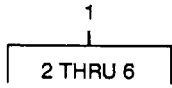

FIGURE 2. MAIN BODY HARNESS.

SECTION II

TM 5-3895-367-14&P

(1) ITEM NO	(2) SMR CODE	(3) CAGEC	(4) PART NUMBER	(5) DESCRIPTION AND USABLE ON CODE (UOC)	(6) QTY
				GROUP 0613 HULL CHASSIS WIRING HARNESS	
				FIG. 2 MAIN BCDY HAPNESS	
1	PAOOO	09780	SA-24220-8-1	WIRING HARNESS, BRAN	1
2	MOOZZ	09780	24233-23	.CABLE ASSEPELY MAKE FFCM CABLE, P/ N 24296.....	1
3	PAOZZ	96906	MS75020-1	CONNECTOR, PLUG, ELEC.....	1
4	MOOZZ	09780	24238-06	.CABLE ASSEPBLY MAKE FACM CABLE, P/ N 24296.....	1
5	PAOZZ	96906	MS25036-157	.TERMINA, LUG.....	2
6	PAOZZ	19328	4920C5	.TERMINAL, QUICK DISC	9

END GF FIGURE

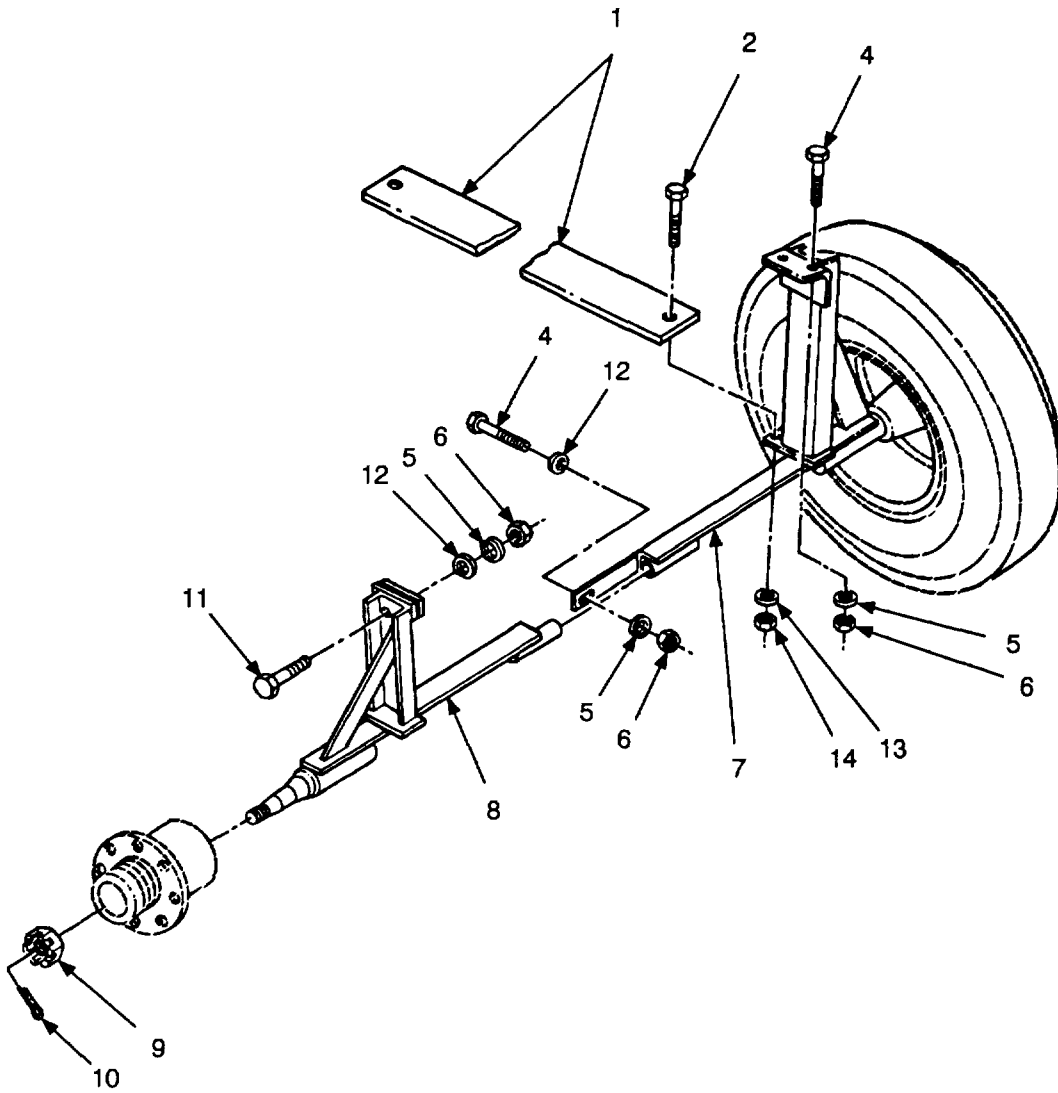
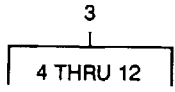

FIGURE 3. AXLE ASSEMBLY (TRANSPORT) AND MOUNTING HARDWARE.

SECTION II

TM 5-3895-367-14&P

(1) ITEM NO	(2) SMR CODE	(3) CAGEC	(4) PART NUMBER	(5) DESCRIPTION AND USABLE ON CODE (UOC)	(6) QTY
				GROUP 11 REAR AXLE	
				GROUP 1100 REAR AXLE ASSEMBLY	
				FIG. 3 AXLE ASSEMBLY (TRANSPORT) AND MOUNTING HARDWARE	
1	PFOZZ	09780	20300-A	BRACKET, MOUNTING	1
* 2	PAOZZ	80204	B181BHO50C175N	SCREW, CAP, HEXAGON H.....	2
3	XDOOO	09780	SA-20298-D	TRUCK ASSEMBLY TRANSPORT	1
* 4	PAOZZ	80204	B18218H063C200N	.SCREW, CAP, HEXAGON H.....	3
5	PAOZZ	96906	MS35333-50	.WASHER, LOCK	5
6	PAOZZ	96906	MS51967-20	.NUT, PLAIN, HEXAGON	5
7	PFOFF	09780	SA-20301-C	.AXLE ASSEMBLY,RIGHT RIGHT HAND	1
3	PFOZZ	09780	SA-20306-C	.AXLE ASSEMBLY,LEFT LEFT HAND.....	1
9	PAOZZ	09780	24260	.NUT,PLAIN, SLOTTED, H	2
10	PAOZZ	09780	24261	.PIN, COTTER	2
* 11	PAOZZ	80204	B18218H063C250N	.SCREW, CAP, HEXAGON H.....	2
12	PAOZZ	96906	MS27183-21	.WASHER,FLAT	V
13	PAOZZ	96906	MS35338-48	WASHER, LOCK	1
14	PAOZZ	96906	MS51967-14	NUT, PLAIN, HEXAGON	1

END OF FIGURE

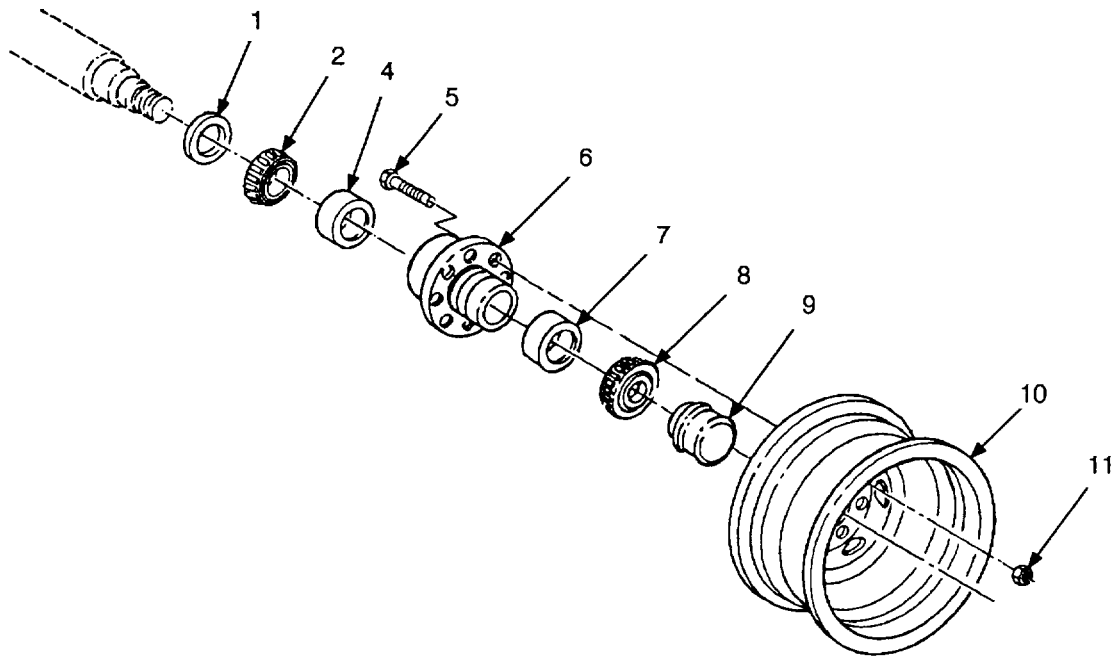
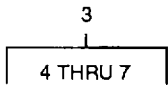

FIGURE 4. TRANSPORT WHEEL AND HUB COMPONENTS.

SECTION II

TM 5-3895-367-14&P

(1) ITEM NO	(2) SMR CODE	(3) CAGEC	(4) PART NUMBER	(5) DESCRIPTION AND USABLE ON CODE (UOC)	(6) QTY
GROUP 13 WHEELS AND TRACKS					
GROUP 1311 WHEEL ASSEMBLY					
FIG. 4 TRANSPORT WHEEL AND HUB COMPONENTS					
1	PAOZZ	09780	24255	SEAL,PLAIN.....	1
2	PAOZZ	09780	24253	CONE AND ROLLERS, TA.....	1
3	XDOOO	09780	57-632	HUB SUBASSEMBLY.....	1
4	PAOZZ	60038	25520	.CUP,TAPERED ROLLER.....	1
* 5	PAOZZ	72741	610-176	.BOLT, RIBBED SHOULDE 1/2 INCH - 20 UNF, RIGHT HAND THREAD X 2 INCHES LONG.....	8
6	XDOZZ	09780	24248	.HUB, WHEEL.....	1
7	PAOZZ	31245	7135-01	.CUP, TAPERED ROLLER.....	1
8	PAOZZ	1DF03	14125A	CONE AND ROLLERS, TA.....	1
9	PAOZZ	09780	24256	CAP, GREASE.....	1
10	PFOZZ	09780	24-1597	RIM, WHEEL, PNEUMATIC.....	1
11	PAOZZ	09780	24258	NUT, PLAIN, CONE SEAT.....	8

END OF FIGURE

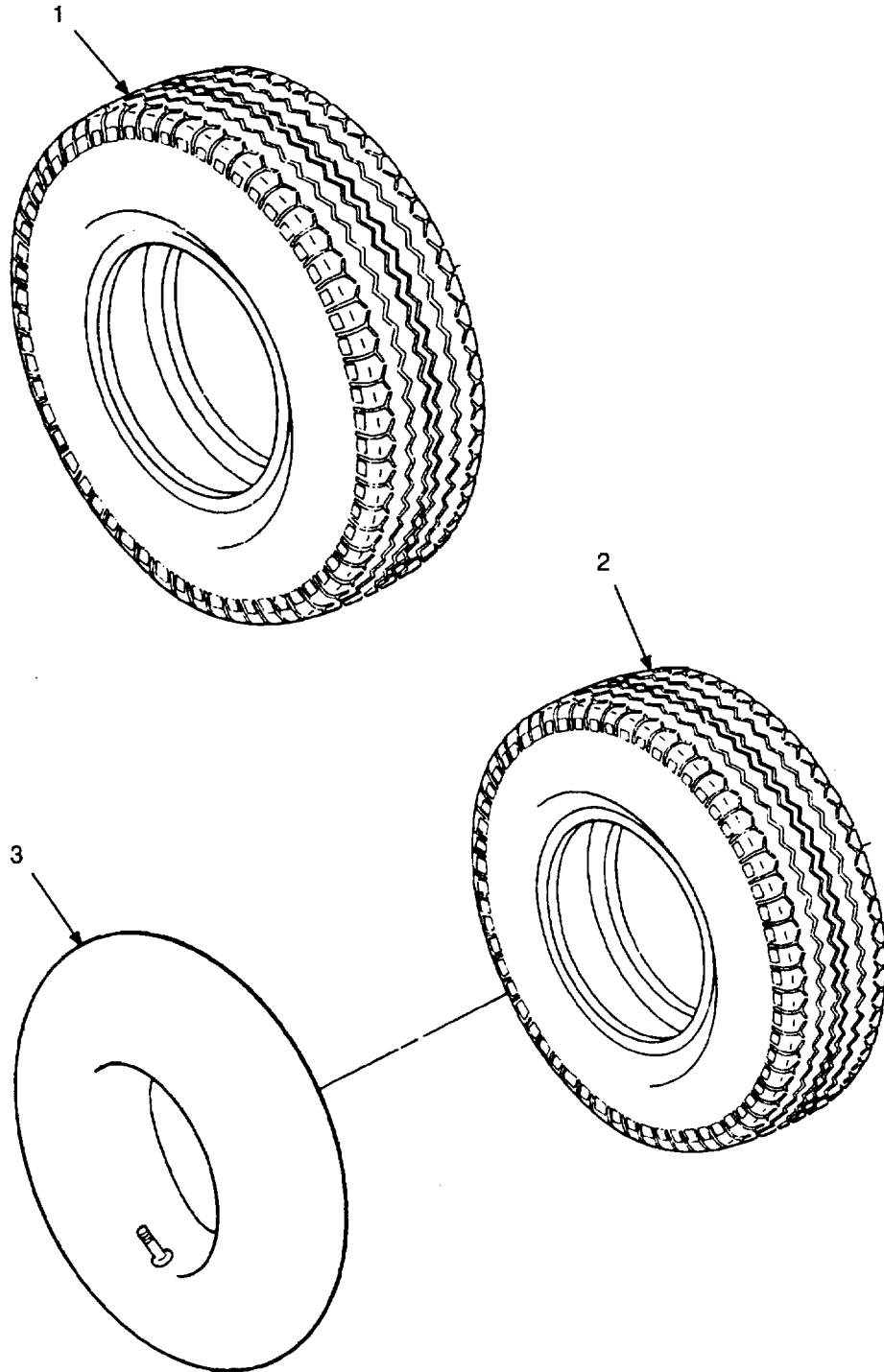

FIGURE 5. TIRES AND TUBES.

(1) ITEM NO	(2) SMR CODE	(3) CAGEC	(4) PART NUMBER	(5) DESCRIPTION AND USABLE ON CODE (UOC)	(6) QTY
				GROUP 1313 TIRES, TLBES# TIRE CHAINS	
				FIG. 5 TIRES ANO TUBES	
1	PAOFH	81349	MIL-T-12459/CLMS S8B/9 .00-16D/DMS	TIRE, FNEUHATIC	1
2	PACFH	96906	MS35389-E4	TIRE,,FEUMATIC	1
3	PAOCO	73808	6-00X9	INNER TUBE, PNEUMATI	1
				ENG OF FIGURE	

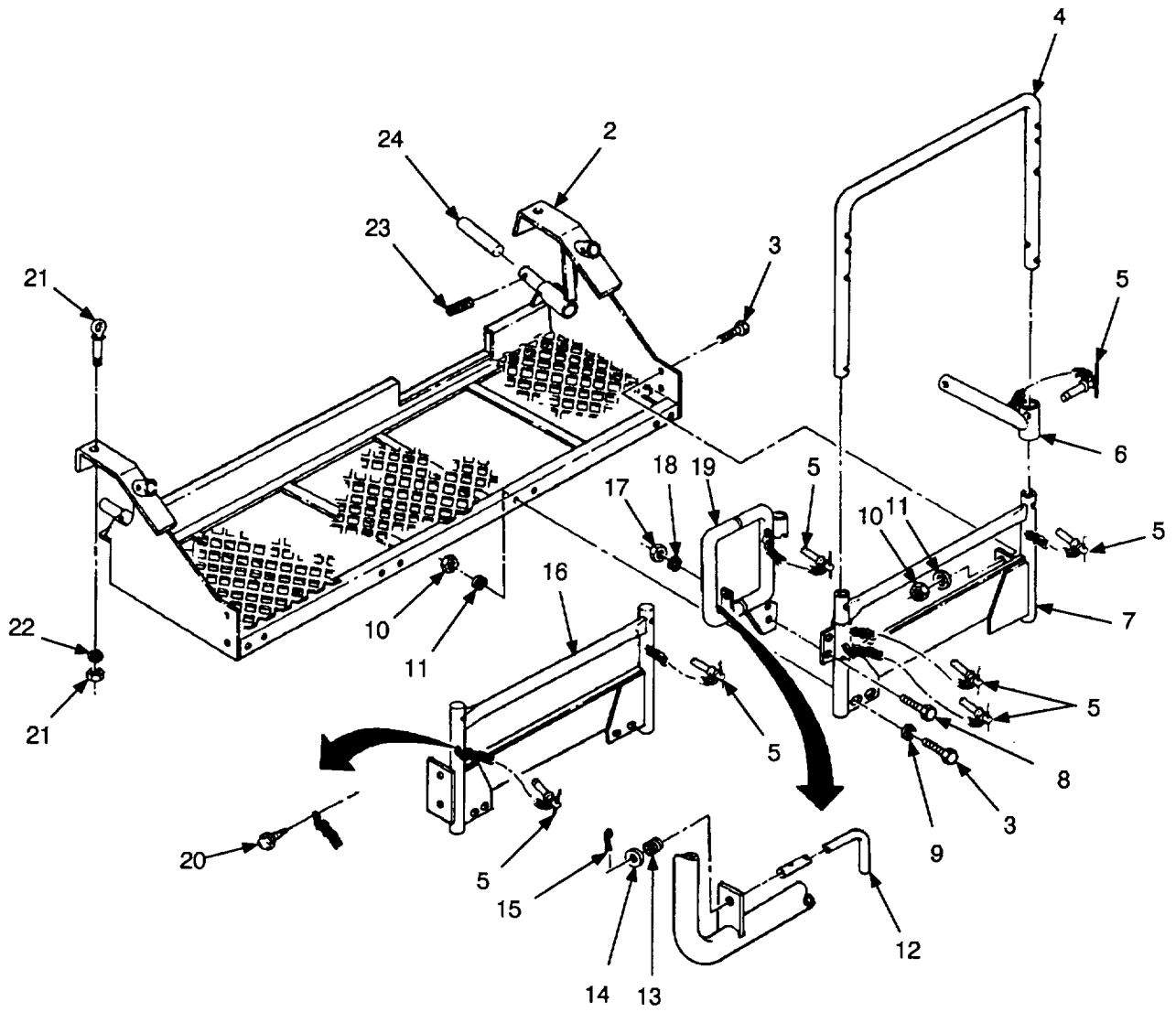
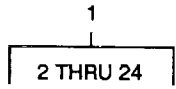

FIGURE 6. OPERATOR PLATFORM ASSEMBLY AND COMPONENTS.

(1) ITEM NO	(2) SMR CODE	(3) CAGEC	(4) PART NUMBER	(5) DESCRIPTION AND USABLE ON CODE (UOC)	(6) QTY
				GROUP 15 FRAME, TOWING ATTACHMENTS, DRAWBARS, AND ARTICULATION SYSTEMS	
				GROUP 1501 FRAME ASSEMBLY	
				FIG. 6 OPERATOR PLATFORM ASSEMBLY AND COMPONENTS	
1	XDOOO	09780	SA-19672-D	PLATFORM ASSEMBLY OPERATOR'S.....	1
2	XDOZZ	09780	SA-19668-D	.PLATFORM.....	1
* 3	PAOZZ	80204	B1821BH050C125N	.SCREW,CAP,HEXAGON H.....	12
4	XDOZZ	09780	19672-DA	.FRAME ASSEMBLY TOP RAIL.....	2
5	PAOZZ	96906	MS17990-827	.PIN,QUICK RELEASE	10
6	XDOZZ	09780	19672-DE	.SUPPORT BRACKET ASS EMBLY TOP FRAME ASSEMBLY	2
7	XDOZZ	09780	19672-OC	.FRAME SUPPORT ASSEM.....	1
* 8	PAOZZ	80204	B1821BHO38C100N	.SCREW, CAP, HEXAGON H.....	2
9	PAOZZ	96906	MS27183-17	.WASHER, FLAT	8
10	PAOZZ	96906	MS51967-14	.NUT, PLAIN, HEXAGON	12
11	PAOZZ	96906	MS35338-48	.WASHER, LOCK	12
12	PAOZZ	09780	19672-014	.HANDLE, MANUAL CONTR.....	1
13	PAOZZ	09780	19672-015	.SPRING,HELICAL,COMP.....	1
14	PAOZZ	96906	MS27183-21	.WASHER, FLAT	1
15	PAOZZ	96906	MS24665-353	.PIN, COTTER	1
16	XDOZZ	09780	19672-DB	.FRAME SUPPORT ASSEM.....	1
17	PAOZZ	96906	MS51967-8	.NUT, PLAIN, HEXAGON	2
18	PAOZZ	96906	MS35333-46	.WASHER, LOCK	2
19	XDOZZ	09780	19672-OD	.GATE ASSEMBLY	1
20	PAOZZ	96906	MS51869-5	.SCREW,TAPPING	10
21	PAOZZ	09780	24263-A-11	.BOLT, EYE INCLUDES NUT	2
22	PAOZZ	96906	MS35338-51	.WASHER, LOCK	2
23	PAOZZ	96906	MS51963-140	.SETSCREW.....	2
24	XDOZZ	09780	SA-10074-5	.PIPE, TELESLOPIC.....	2

END OF FIGURE

11
├──
└─┬─
 12 THRU 14

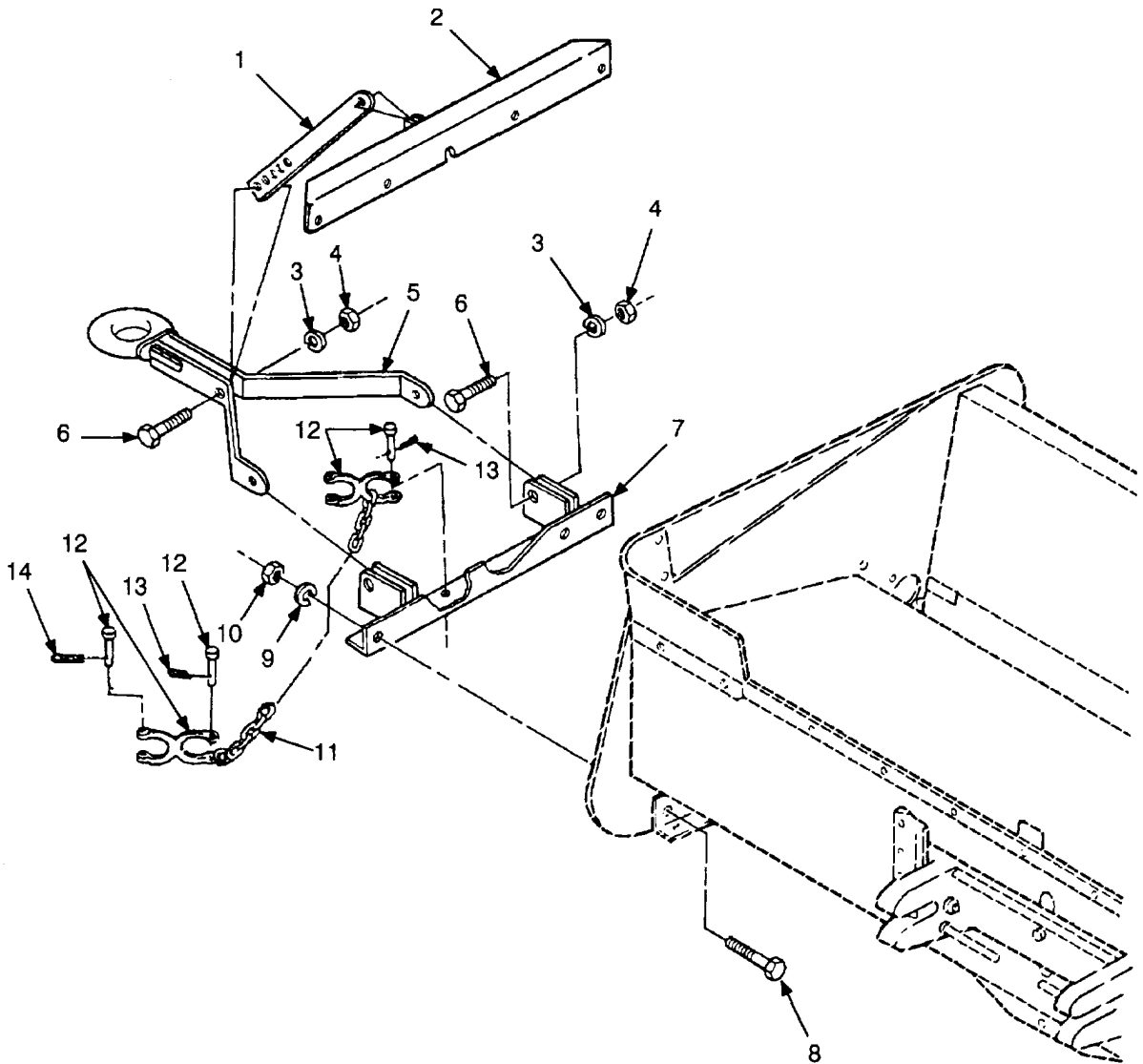

FIGURE 7. TRANSPORT TONGUE COMPONENTS.

SECTION II

TM 5-3895-367-14&P

(1) ITEM NO	(2) SMR CODE	(3) CAGEC	(4) PART NUMBER	(5) DESCRIPTION AND USABLE ON CODE (UOC)	(6) QTY	
				GROUP 1503 PINTLES AND TOWING ATTACHMENTS		
				FIG. 7 TRANSPORT TONGUE COMPONENTS		
1	PAOZZ	09780	9334-A	BAR, METAL.....	1	
2	PAOZZ	09780	SA-9340-A	FRAME SECTION, STRUC.....	1	
3	PAOZZ	96906	MS35338-50	WASHER, LOCK.....	4	
4	PAOZZ	96906	MS51967-20	NUT, PLAIN, HEXAGON.....	4	
5	PAOZZ	09780	SA-20313-B	DRAWBAR, POLE TRAILER.....	1	
*	6	PAOZZ	80204	B1821BH063C250N	SCREW, CAP, HEXAGON.....	4
	7	XDOZZ	09780	SA-9338-A	ANGLE ASSEMBLY.....	1
*	8	PAOZZ	80204	B1821BH050C150N	SCREW, CAP, HEXAGON H.....	7
	9	PAOZZ	96906	MS35338-48	WASHER, LOCK.....	7
	10	PAOZZ	96906	MS51967-14	NUT, PLAIN, HEXAGON.....	7
	11	PAOOO	09780	SA-20434-A	CHAIN ASSEMBLY, SING.....	2
	12	XDOZZ	09780	SA-20434-A2	.CLEVIS.....	2
	13	PAOZZ	96906	MS24665-283	.PIN, COTTER.....	3
	14	XDOZZ	09780	SA-20434-A3	.PIN, HAIR.....	1

END OF FIGURE

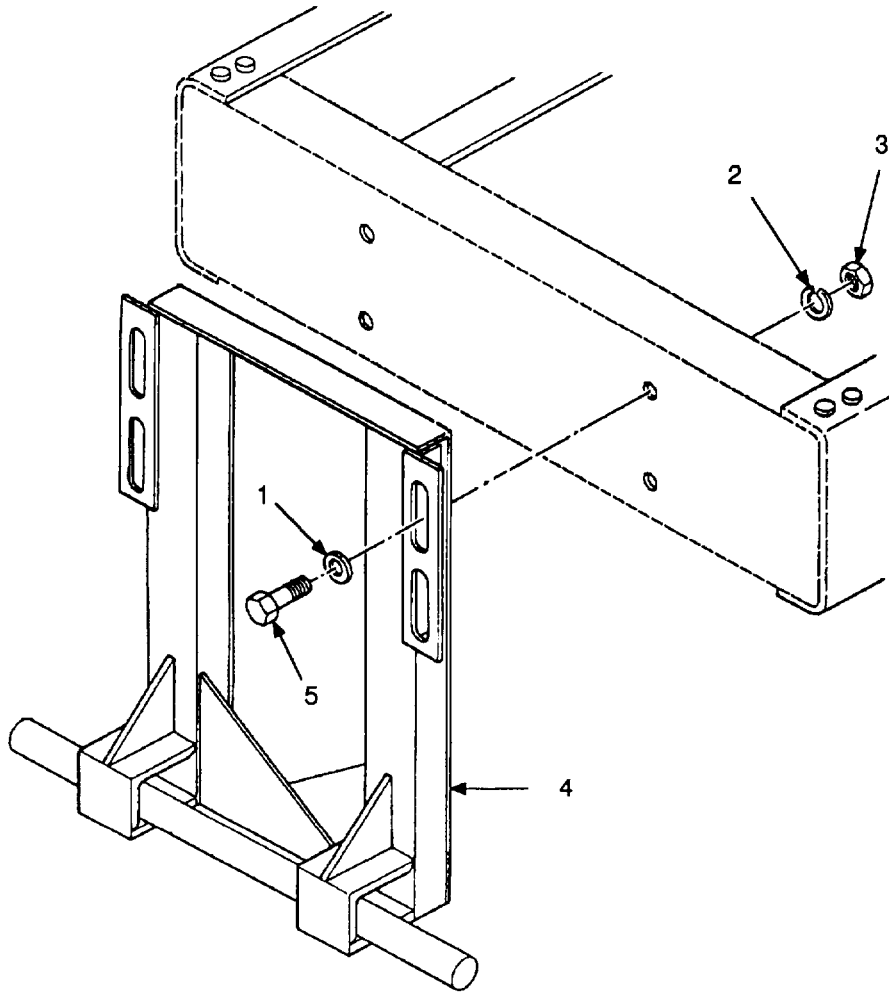

FIGURE 8. TRUCK HITCH COMPONENTS.

SECTION II

TM 5-3895-367-14&P

(1) ITEM NO	(2) SMR CODE	(3) CAGEC	(4) PART NUMBER	(5) DESCRIPTION AND USABLE ON CODE (UOC)	(6) QTY
GROUP 1503 PINTLES AND TOWING ATTACHMENTS					
FIG. 8 TRUCK HITCH COMPONENTS					
1	PAOZZ	88044	AN960-1216	WASHER,FLAT	4
2	PAOZZ	96906	MS35338-48	WASHER, LOCK	4
3	PAOZZ	96906	MS51967-14	NUT, PLAIN, HEXAGON	4
4	PFOZZ	09780	SA-20232-D	HITCH,TRUCK AND TRA	1
* 5	PAOZZ	80204	B18218H050C450N	SCREW, CAP,HEXAGON H.....	4

END OF FIGURE

1
2 THRU 14

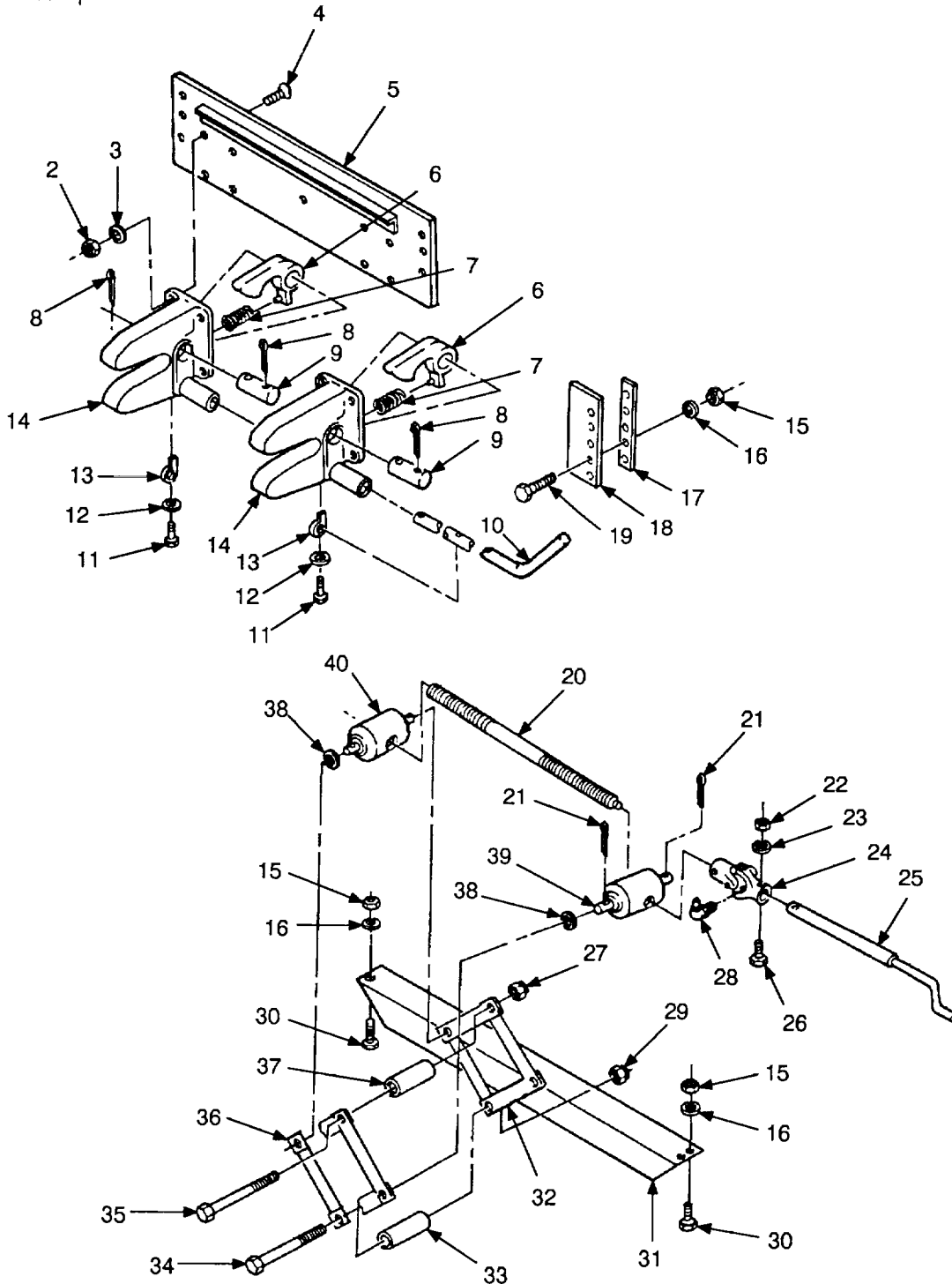

FIGURE 9. COUPLER HITCH ASSEMBLY AND RELATED PARTS.

SECTION II

TM 5-3895-367-14&P

(1) ITEM NO	(2) SMR CODE	(3) CAGEC	(4) PART NUMBER	(5) DESCRIPTION AND USABLE ON CODE (UOC)	(6) QTY	
GROUP 1503 PINTLES AND TOWING ATTACHMENTS						
FIG. 9 COUPLER HITCH ASSEMBLY AND RELATED PARTS						
1	XDFFF	09781	SA-8326-D	HITCH ASSEMBLY COUPLER	1	
2	PAFZZ	96906	MS51967-14	.NUT, PLAIN, HEXAGON	8	
3	PAFZZ	96906	MS35338-48	.WASHER, LOCK	18	
4	PAFZZ	96906	MS35754-34	.BOLT, SQUARE NECK.....	8	
5	XDFZZ	09780	SA-5150-B	.BAR ASSEMBLY, HITCH	1	
6	PAFZZ	09780	SA-22329-8	.DOG, QUICK DISCONNEC.....	2	
7	PAFZZ	09780	2202-A	SPRING, HELICAL, COMP.....	2	
8	PAFZZ	96906	MS24665-500	.PIN, COTTER	4	
9	XDFZZ	09780	2176-A	.SHAFT	2	
10	XDFZZ	09780	8790-C	.LEVER, LATCH.....	1	
*	11	PAFZZ	80204	B1821BH038C100N	.SCREW,CAP,HEXAGON H	2
12	PAFZZ	96906	MS35338-46	.WASHER,LOCK	2	
13	PAFZZ	09780	7293-A	.LATCH,PINTLE HOOK	2	
14	XDFZZ	09780	5382-DW	.HOUSING,HITCH	2	
15	PAFZZ	96906	MS51967-14	NUT, PLAIN, HEXAGON	14	
16	PAFZZ	96906	MS35338-48	WASHER,LOCK	14	
17	PFFZZ	09780	2193-A	SPACER, SLEEVE.....	2	
18	PFFZZ	09780	2192-A	SPACER,PLATE	2	
*	19	PAFZZ	80204	B1321BH050C250N	SCREW, CAP,HEXAGON H.....	10
20	PFFZZ	09780	2196-B	SCREW,MACHINE	1	
21	PAFZZ	96906	MS24665-500	PIN, COTTER	4	
22	PAFZZ	96906	MS51967-8	NUT,PLAIN,HEXAGON	2	
23	PAFZZ	96906	MS35338-46	WASHER, LOCK	2	
24	PAFZZ	06495	101-2-101	UNIVERSAL JOINT	1	
25	XDFZZ	09780	7611-B	CRANK, ASSEMBLY	1	
*	26	PAFZZ	80204	B1821BH038C225N	SCREW,CAP, HEXAGON H.....	2
27	PAFZZ	96906	MS51943-49	NUT, SELF-LOCKING,HE	1	
28	PAFLZ	96906	MS15001-4	FITTING,LUBRICATION	1	
29	PAFZZ	96906	MS51943-45	NUT, SELF-LOCKING,HE	1	
*	30	PAFZZ	80204	B1821BH050C125N	SCREW,CAP,HEXAGON H.....	4
31	XDFZZ	09780	10349-B	ANGLEICOUPLER.....	1	
32	XDFZZ	09780	2130-A	PANTOGRAPH LINKS,UP.....	4	
33	PFFZZ	09780	2127	SPACER,SLEEVE 1 INCH STANDARD PIPE.....	1	
34	PAFZZ	09780	2195	X 4 INCHES LONG	1	
35	PAFZZ	09780	2194-A	BOLT,MACHINE 3/4 INCH - 10 UNC X 8.....	1	
36	XDFZZ	09780	2131-A	INCH LONG	1	
37	PFFZZ	09780	5889	BOLT,MACHINE 1 INCH-8UNC X 10.....	1	
38	PAFZZ	96906	MS27183-27	INCHES LONG	4	
39	PFFZZ	09780	3314-BF2	LINK,LOWER	1	
40	PFFZZ	09780	3314-BF1	SPACER,SLEEVE 3/4 INCH STANDARD.....	1	
				PIPE X 4 INCH LONG.....	4	
				WASHER,FLAT	1	
				NUT,PLAIN,BARREL LEFT HAND.....	1	
				NUT,PLAIN,BARREL RIGHT HAND	1	

END OF FIGURE

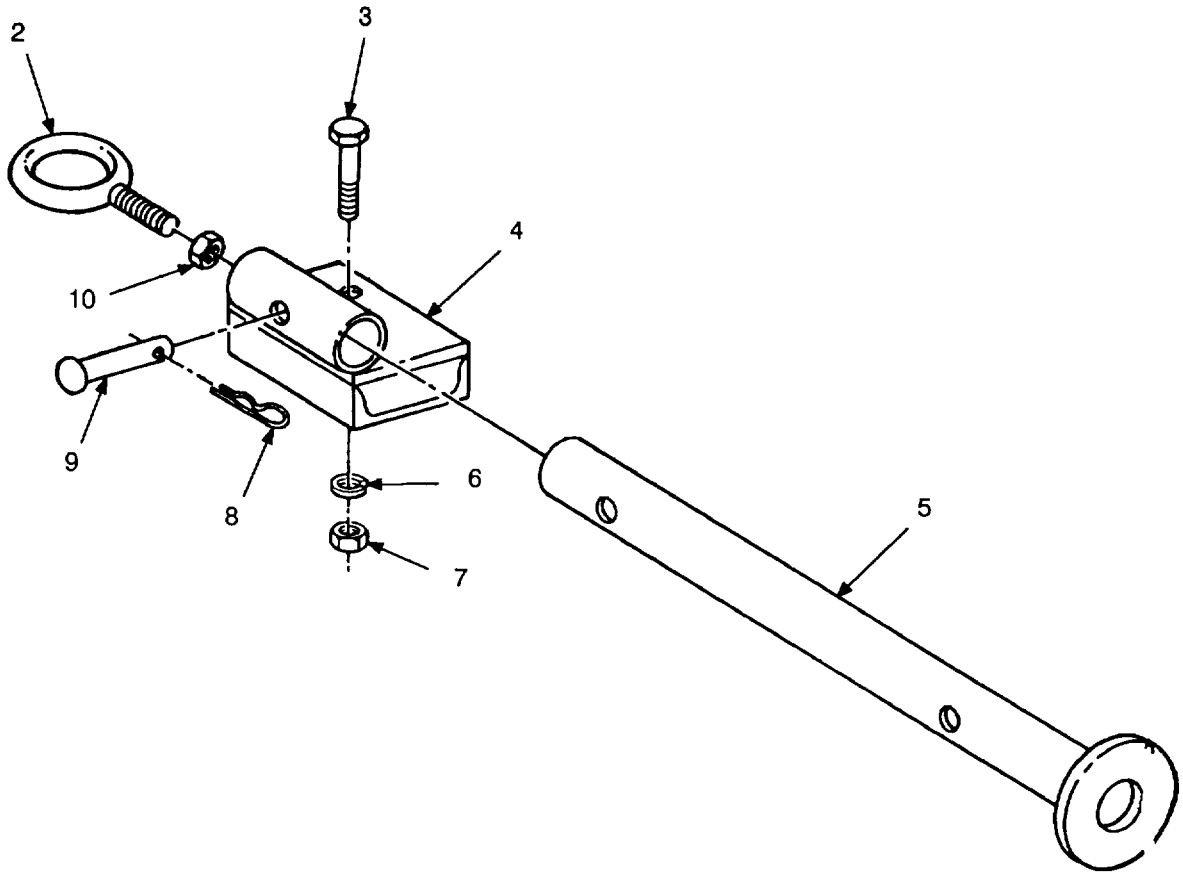
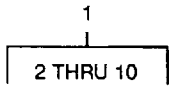

FIGURE 10. LEVELING LEG ASSEMBLY.

SECTION II

TM 5-3895-367-14&P

(1) ITEM NO	(2) SMR CODE	(3) CAGEC	(4) PART NUMBER	(5) DESCRIPTION AND USABLE ON CODE (UOC)	(6) QTY
GROUP 1507 LANDING CEAF, LEVELING JACKS					
FIG. 10 LEVELING LEC ASSEPPLY					
1	XDOOO	09780	24265-B	JACK LEG ASSY	2
2	XCOZZ	09780	24265-B5	.EYEBCLT 5/16 X 18 UNC.....	1
3	PAOZZ	96906	MS51095-420	.SCREW,CAP,HEXAGON H.....	1
4	XDCZZ	09780	SA-20403-A	.BRACKET,JACK LEG	1
5	XDOZZ	09780	SA-20402-A	.LEG,JACK.....	11
6	PAOZZ	96906	MS35338-48	.WASHER,LOCK	1
7	PAOZZ	96906	MS51967-14	.NUT,PLAIN, HEXAGON	1
8	PAOZZ	88044	AN415-6	.PIN,LOCK	1
9	PAOZZ	09780	7155-A	.PIN,STRAIGHT,HEADEC 5/8 INCF X 3 1/2 INCH	1
10	PAOZZ	96906	MS51967-5	.NUT,PLAIN,HEXAGON	1

END OF FIGURE

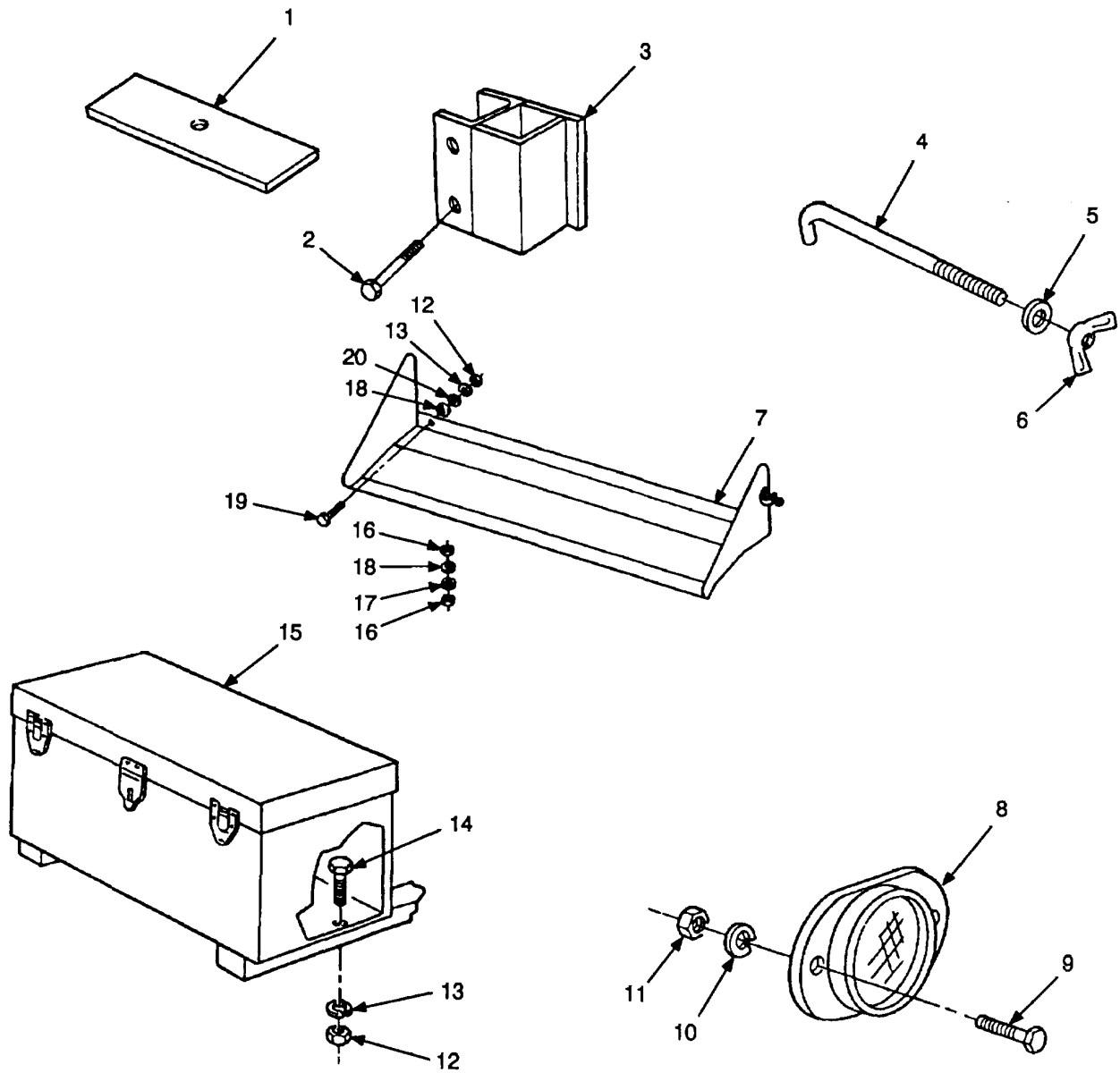

FIGURE 11. REFLECTOR, TOOLBOX, AND ACCESSORY ITEMS.

SECTION II

TM 5-3895-367-14&P

(1) ITEM NO	(2) SMR CODE	(3) CAGEC	(4) PART NUMBER	(5) DESCRIPTION AND USABLE ON CODE (UOC)	(6) QTY
				GROUP 22 BODY, CHASSIS, AND HULL ACCESSORY ITEMS	
				GROUP 2202 ACCESSORY ITEMS	
				FIG. 11 REFLECTOR, TOOLBOX, AND ACCESSORY ITEMS	
1	XDOZZ	09780	20491-A	BAR, PLATFORM HOLD	4
2	PAOZZ	21450	193031	SCREW, CAP, HEXAGON H USED ON MODELS	4
				M929A1, M929A2, M930A1, M930A2, DUMP TRUCKS.....	
3	XDOZZ	09780	24299-B	SPACER, SPECIAL USED ON MODELS.....	2
				M929A1, M929A2, M930A1, M930A2, DUMP TRUCKS.....	
4	MOOZZ	09780	20492-A	BOLT, J MAKE FROM BOLT P/N MS90728-	4
5	PAOZZ	96906	MS35338-46	WASHER, LOCK	4
6	PAOZZ	96906	MS35425-74	NUT, PLAIN, WING	4
7	XDOZZ	09780	24300-C	CHUTE, SPECIAL USED ON MODELS	1
				M929A1, M929A2, M930A1, M930A2, DUMP TRUCKS.....	
8	PAOZZ	96906	MS35387-1	REFLECTOR, INDICATING	2
9	PAOZZ	96906	MS90725-3	SCREW, CAP, HEXAGON H.....	4
10	PAOZZ	96906	MS35338-44	WASHER, LOCK	4
11	PAOZZ	96906	MS51967-2	NUT, PLAIN, HEXAGON	4
12	PAOZZ	96906	MS51967-8	NUT, PLAIN, HEXAGON	4
13	PAOZZ	96906	MS35338-46	WASHER, LOCK	4
14	PAOZZ	96906	MS90725-60	SCREW, CAP, HEXAGON H.....	2
15	XDOZZ	09780	SA-20356-8	TOOL BOX.....	1
16	PAOZZ	96906	MS51967-14	NUT, PLAIN, HEXAGON	4
17	PAOZZ	96906	MS35338-48	WASHER, LOCK	2
18	PAOZZ	96906	MS27183-17	WASHER, FLAT,	4
*	PAOZZ	80204	B1821BH038C250N	SCREW, CAP, HEXAGON H.....	2
20	PAOZZ	96906	MS27183-14	WASHER, FLAT	2

END OF FIGURE

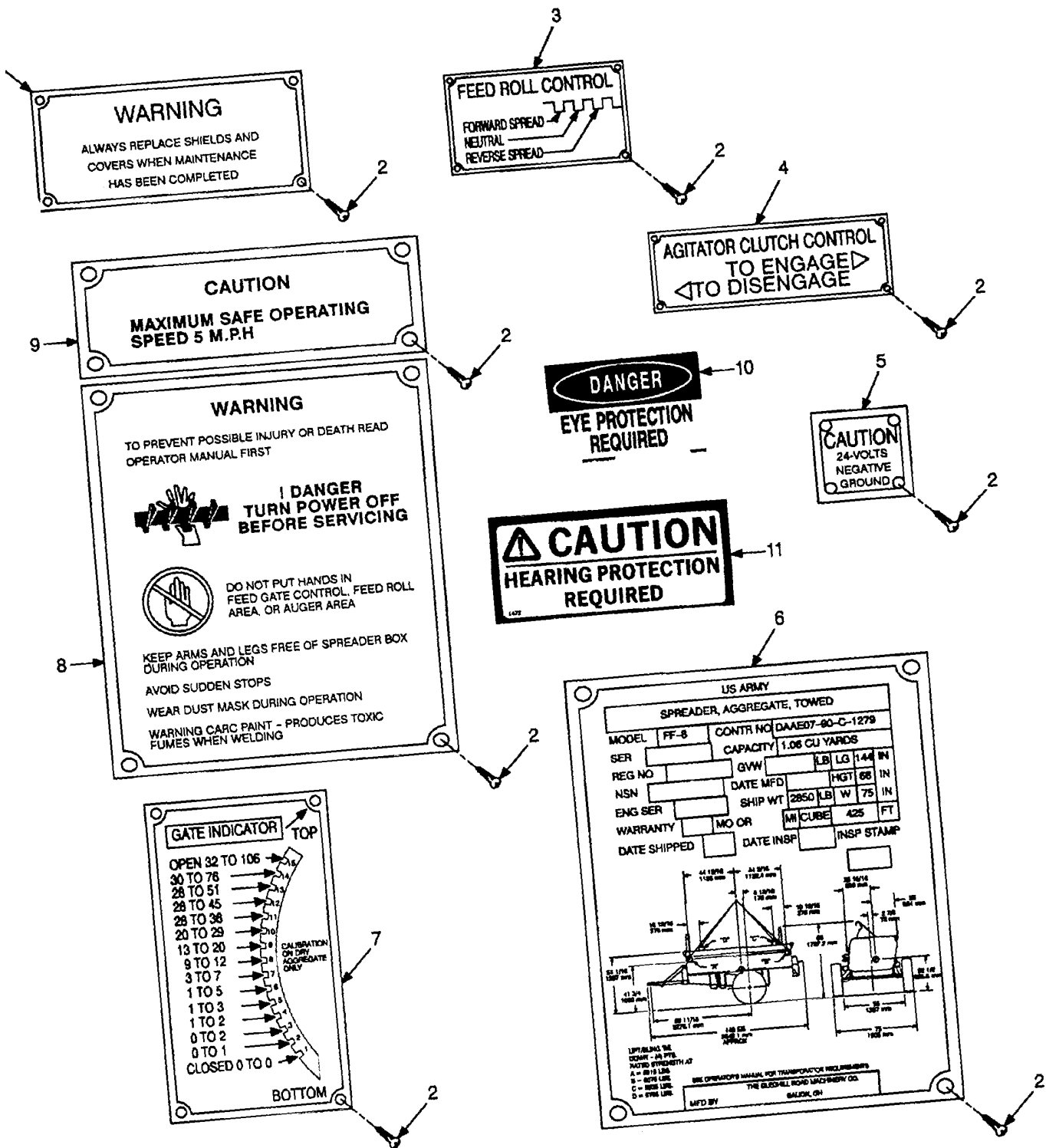

FIGURE 12. DATA PLATES.

SECTION II

TM 5-3895-367-14&P

(1) ITEM NO	(2) SMR CODE	(3) CAGEC	(4) PART NUMBER	(5) DESCRIPTION AND USABLE ON CODE (UOC)	(6) QTY
GROUP 2210 DATA PLATES AND INSTRUCTION HOLDERS					
FIG 12 DATA PLATES					
1	PAOZZ	09780	24228-A	PLATEIDENTIFICATIO.....	1
2	PAOZZ	96906	MS21318-27	SCREWTDRIVE	36
3	PAOZZ	09780	20517-A	PLATE,IDENTIFICATIO.....	1
4	PADZZ	09780	20518-A	PLATE,IDENTIFICATIO.....	1
5	PAOZZ	09780	24250-A	PLATE,INSTRUCTION	1
6	PAOZZ	09780	24227-B	PLATE,IDENTIFICATIO.....	1
7	PAOZZ	09780	20371-A	PLATE,IDENTIFICATIO.....	1
8	PAOZZ	09780	24226-B	PLATE,INSTRUCTION	1
9	PFOZZ	09780	24298-A	PLATE,INSTRUCTION	1
* 10	PAOZZ	58752	S32-23	MARKER, IDENTIFICAT.....	1
* 11	PAOZZ	12361	7-376-001472	MARKERS IDENTIFICAT	1

END OF FIGURE

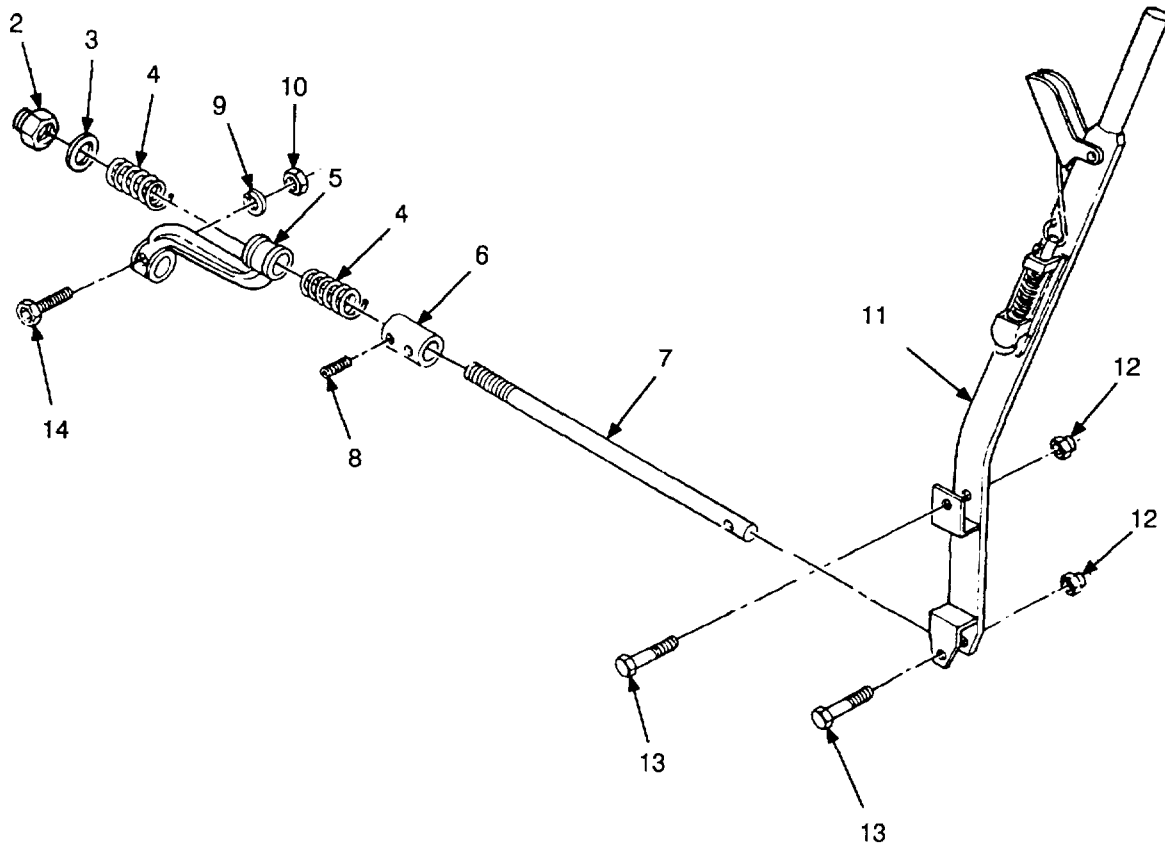
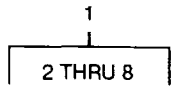

FIGURE 13. CLUTCH SHIFT ARM AND FEED ROLL CONTROL LEVER.

SECTION II

TM 5-3895-367-14&P

(1) ITEM NO	(2) SMR CODE	(3) CAGEC	(4) PART NUMBER	(5) DESCRIPTION AND USABLE ON CODE (UOC)	(6) QTY	
GROUP 73 CONCRETE AND ASPHALT EQUIPMENT COMPONENTS						
GROUP 7303 CONTROLS						
FIG 13 CLUTCH SHIFT ARM AND FEED ROLL CONTROL LEVER						
1	PAOOO	09780	SA-8854-B	TRANSMISSION SHIFTI SHIFTING	1	
2	PAOZZ	96906	MS51943-43	.NUT,SELF-LOCKING,HE	1	
3	PAOZZ	96906	MS27183-21	.WASHER,FLAT	1	
4	PAOZZ	09780	8183-A	.SPRING,HELICAL,COMP.....	2	
5	PAOZZ	09780	5379-C-DW	.BRACKET MOUNTING	1	
6	PAOZZ	09780	8855-A	.COLLAR,SHAFT	1	
7	PAOZZ	09780	2227-A	.SHAFT, STRAIGHT	1	
8	PAOZZ	96906	MS51963-105	.SETSCREW,.....	2	
9	PAOZZ	96906	MS35338-44	WASHER, LOCK	1	
10	PAOZZ	96906	MS51967-2	NUTIPLAINVHEXAGON	1	
11	PAOZZ	09780	SA-10186-C	LEVER,MANUAL CONTROL CLUTCH	1	
12	PAOZZ	96906	MS51943-35	NUT, SELF-LOCKINGIHE	2	
*	13	PAOZZ	80204	B18218H038C200N	SCREW,CAP,HEXAGON Ho.....	2
*	14	PAOZZ	80204	81821BH025C175N	SCREW,CAP,HEXAGON Hs.....	1

END OF FIGURE

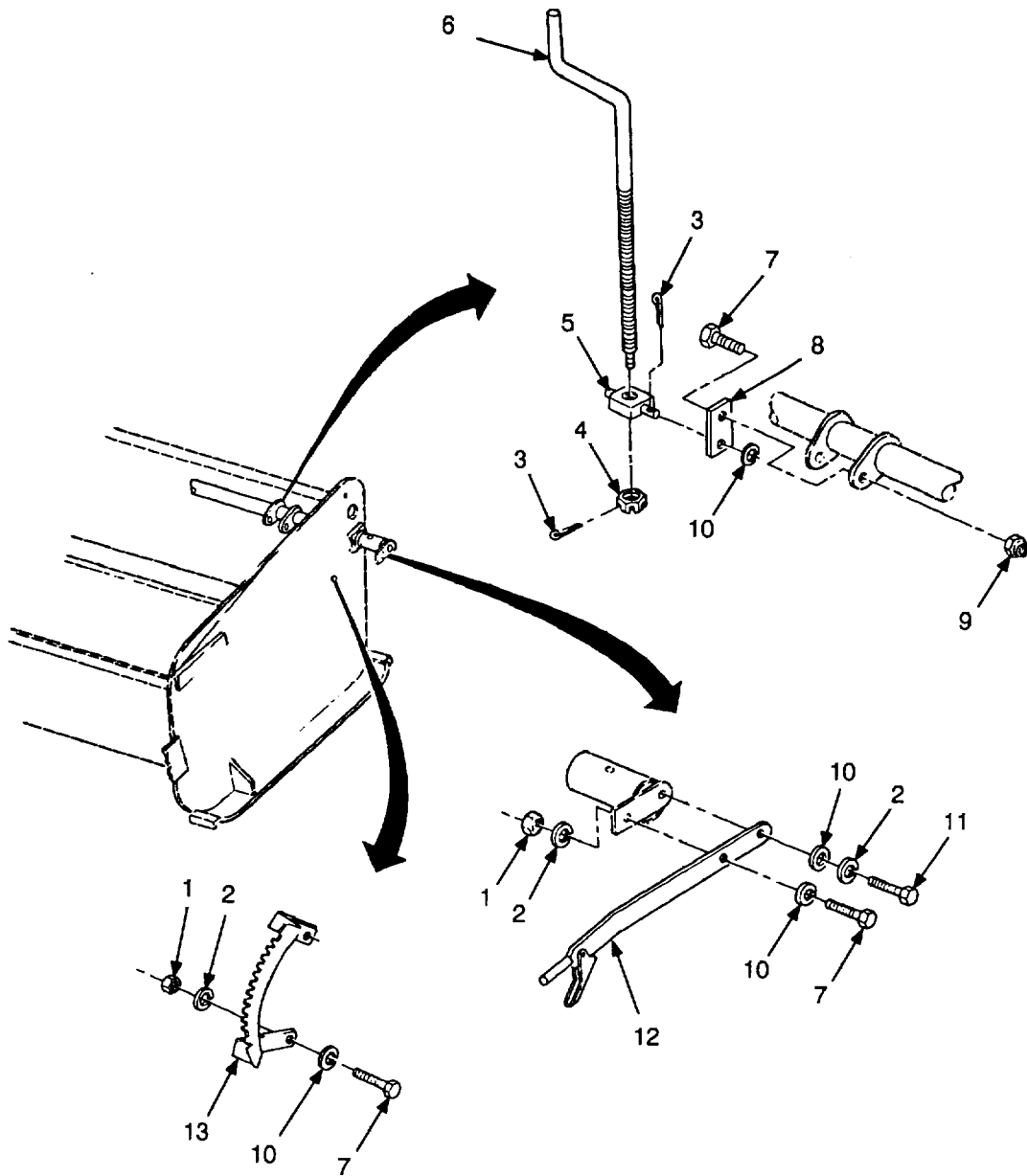

FIGURE 14. GATE CONTROL LEVER AND GATE ADJUSTMENT SCREW COMPONENTS.

SECTION II

TM 5-3895-367-14&P

(1) ITEM NO	(2) SMR CODE	(3) CAGEC	(4) PART NUMBER	(5) DESCRIPTION AND USABLE ON CODE (UOC)	(6) QTY	
GROUP 7303 CONTROLS						
FIG. 14 GATE CONTROL LEVER AND GATE ADJUSTMENT SCREW COMPONENTS						
1	PAOZZ	96906	MS51967-14	NUT,PLAIN,HEXAGON	2	
2	PAOZZ	96906	MS35338-48	WASHER,LOCK	4	
3	PAOZZ	96906	MS24665-360	PIN,COTTER	3	
4	PAOZZ	96906	MS35692-61	NUT,PLAIN,SLOTTED,H	1	
5	XDOZZ	09780	SA-5137-B	SCREW, NUT	1	
6	XDOZZ	09780	2124-8	SCREW,ADJUSTMENT GATET 1 INCH DIAMETER X 37 1/4 INCH LONG	1	
*	7	PAOZZ	80204	B1821BH050C150N	SCREW,CAP,HEXAGON HE	5
	8	XDOZZ	09780	2126-A	YOKE SCREW ARM.....	2
	9	PAOZZ	96906	MS51943-39	NUT,SELF-LOCKING,HE	2
	10	PAOZZ	96906	MS27183-17	WASHER, FLAT.	6
*	11	PAOZZ	80204	B1821BH050C125N	SCREW,CAP,HEXAGON H.....	1
	12	XDOZZ	09780	SA-9783-B	LEVER ASSEMBLY GATE ADJUSTING	1
	13	XDOZZ	09780	SA-2146-C	RACK	1

END OF FIGURE

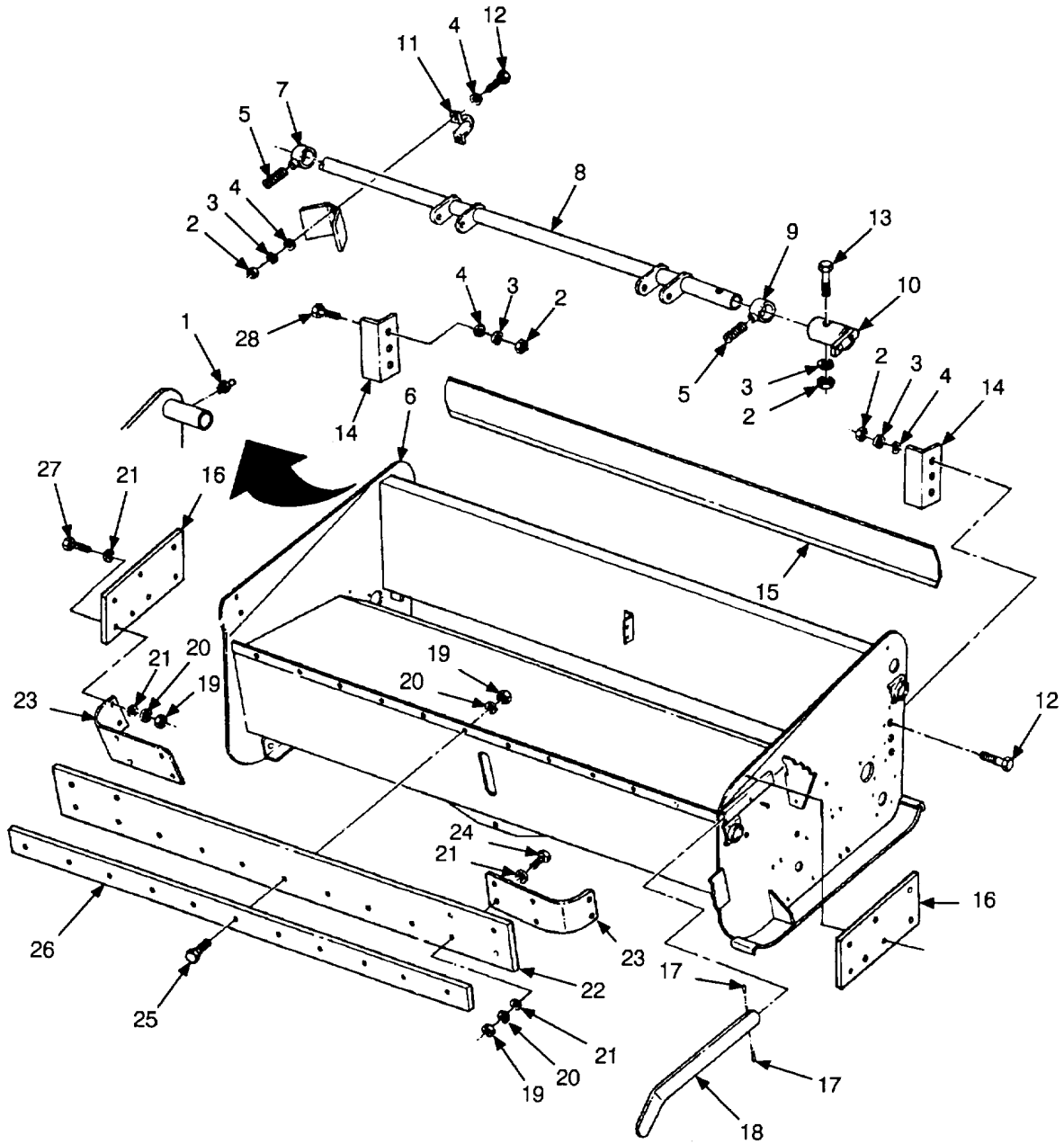
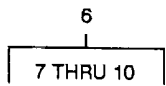

FIGURE 15. HOPPER ASSEMBLY AND GATE RELATED COMPONENTS.

SECTION II

TM5-3895-367-14&PC01

(1) ITEM NO	(2) SMR CODE	(3) CAGEC	(4) PART NUMBER	(5) DESCRIPTION AND USABLE ON CODE (UOC)	(6) QTY
				GROUP 7304 HOPPERS GATES, AND CHUTES	
				FIG* 15 HOPPER ASSEMBLY AND GATE RELATED COMPONENTS	
1	PAOZZ	96906	MS15003-1	FITTING, LUBRICATION.....	1
2	PAOZZ	96906	4S51967-14	NUT, PLAIN, HEXAGON.....	11
3	PAOZZ	96906	MS35338-48	WASHER, LOCK.....	10
4	PAOZZ	96906	MS27183-17	WASHER, FLAT.....	14
5	PAOZZ	96906	MS51955-36	SETSCREW.....	2
6	XDOOO	09780	SA-8448-D	HOPPER ASSEMBLY.....	1
7	PAOZZ	09780	2177-A	.COLLAR, SHAFT.....	1
8	PAOZZ	09780	SA-8450-B	.SHAFT, STRAIGHT GATE ADJUSTING.....	1
9	PAOZZ	09780	SA-2178-A	.COLLAR, SHAFT.....	1
10	PAOZZ	09780	SA-5139-B	.BEARING, SLEEVE.....	1
11	PAOZZ	09780	2122-A	HOUSING, BEARING UNI.....	2
*12	PAOZZ	80204	B1821BH050C150N	SCREW, CAP, HEXAGON H.,.....	8
*13	PAOZZ	80204	B1821BH050C350N	SCREW, CAP, HEXAGON H.6.....	1
14	XDOZZ	09780	2123-A	BRACKET, ANGLE.....	2
15	XDOZZ	09780	SA-8438-B	GATE ASSEMBLY.....	1
16	PAOZZ	09780	30010-A	COVER, ACCESS SIDE.....	2
17	PAOZZ	96906	MS171590	PIN, SPRING.....	4
18	XDOZZ	09780	20444-8	HANDLE, BALANCING FRONT.....	2
19	PAOZZ	96906	MS51967-8	NUT, PLAIN, HEXAGON.....	32
20	PAOZZ	96906	MS35339-46	WASHER, LOCK.....	32
21	PAOZZ	96906	MS27183-14	WASHER, FLAT.....	36
22	PAOZZ	09780	8789-6	BELTING, FLAT CENTER.....	1
23	PAOZZ	09780	20510-AI	BELT1FLAT CORNER SHEET.....	2
*24	PAOZZ	80204	31821BH038C150N	SCREW, CAP, HEXAGON H.....	4
*25	PAOZZ	80204	81321BH038C125N	SCREW, CAP, HEXAGON H.....	24
26	XDOZZ	09780	2260-A	REINFORCEMENT BELTING.....	1
*27	PAOZZ	80204	B18218H038C175N	SCREW, CAP, HEXAGON H.....	4
28	PAOZZ	80204	B1821BH050C200N	SCREW, CAP, HEXAGON H.....	2
				END OF FIGURE	

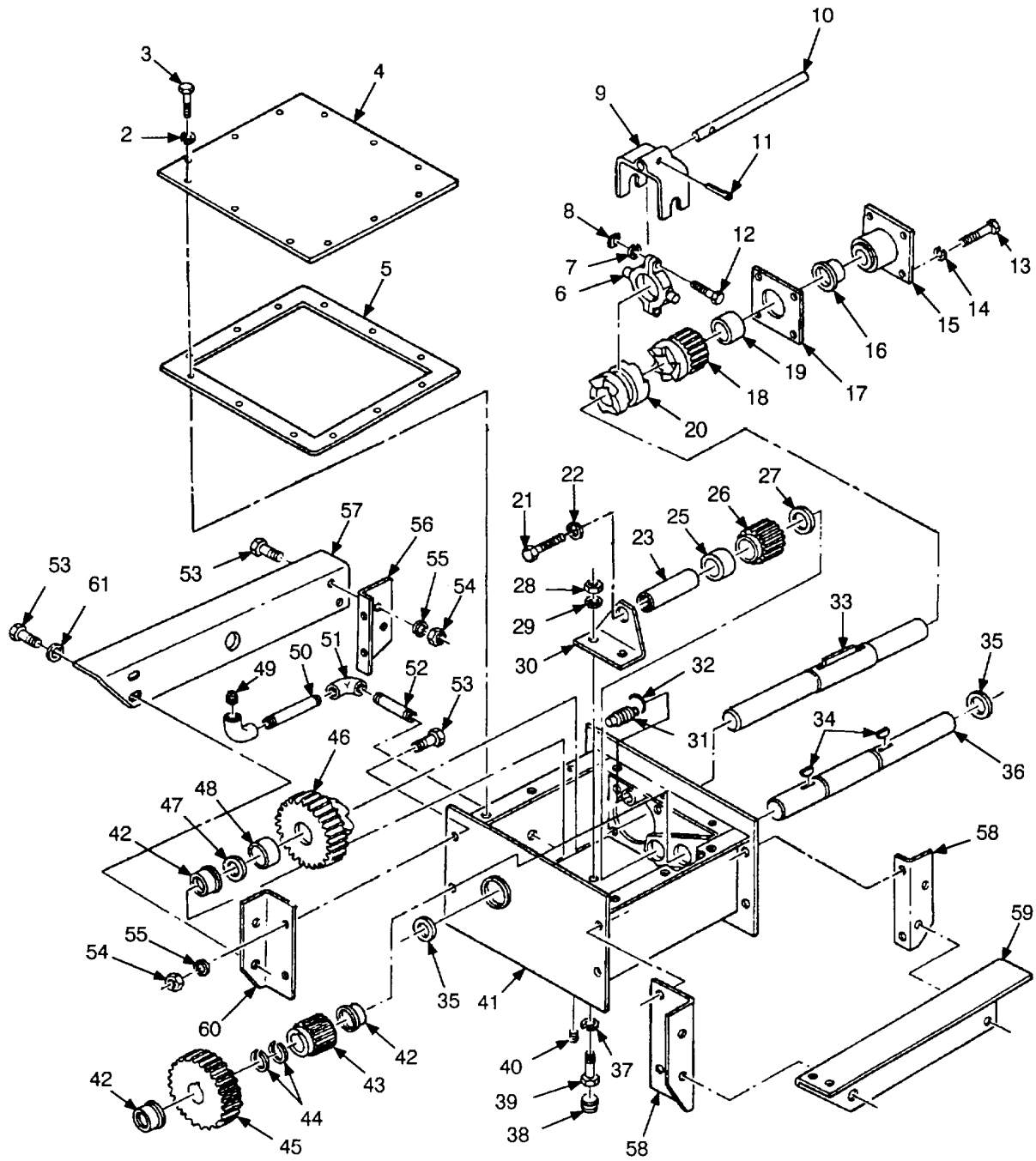
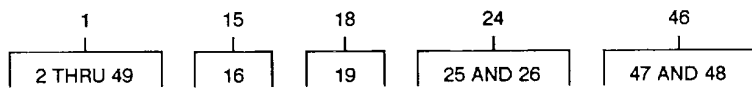

FIGURE 16. GEAR BOX ASSEMBLY.

(1) ITEM NO	(2) SMR CODE	(3) CAGEC	(4) PART NUMBER	(5) DESCRIPTION AND USABLE ON CODE (UOC)	(6) QTY
GROUP 7305 MAIN DRIVE					
FIG. 16 GEARBOX ASSEMBLY					
1	XDOFF	09780	SA-5002-D	GEAR BOX ASSEMBLY	1
2	PAFZZ	96906	MS35338-65	.WASHER, LOCK	14
*3	PAFZZ	80204	B1821BH038C075N	.SCREW,CAP,HEXAGON H.....	12
4	XDFZZ	09780	2216-C	.COVER, ACCESS	1
5	PAFZA	09780	7458-C	.GASKET COVER TO GEAR BOX.....	1
6	PFFZZ	09780	SA-5203-B	.CLAMP, LOOP.....	1
7	PAFZZ	96906	MS35338-45	.WASHER, LOCK	2
8	PAFZZ	96906	MS27040-11	.NUT1PLAINISQUARE.....	2
9	PFFZZ	09780	SA-5140-B	.SHIFTER FORK CLUTCH.....	1
10	PAFZZ	09780	2225-A	.SHAFT, STRAIGHT	1
11	PAFZZ	96906	MS24665-653	.PIN, COTTER	1
*12	PAFZZ	80204	B1821BH031C150N	.BOLT, MACHINE	2
*13	PAFZZ	80204	B1821BH050C125N	.SCREW, CAP, HEXAGON H ,	4
14	PAFZZ	96906	MS35338-48	.WASHER, LOCK	4
15	PFFFF	09780	SA-6946-C	.BUSHING, SLEEVE DRIVE SHAFT.....	1
16	PAFZZ	09780	7386-A	.BUSHING, SLEEVE.....	1
17	PAFZZ	09780	19184-A	.GASKET BUSHING MOUNTING,	1
18	PAFFF	09780	SA-5011-B	.GEAR ASSEMBLY, SPEED	1
19	PAFZZ	09780	2289-A	.BEARING, SLEEVE.....	1
20	PAFZZ	09780	5202-A	.CLUTCH, POSITIVE.....	1
21	PFFZZ	96906	MS90727-185	.SCREW, CAP, HEXAGON H SHAFT SUPPORT..... 3/4 INCH X 1-1/2 INCH SAE CAP SCREW	1
22	PAFZZ	96906	MS35338-51	.WASHER1LOCK	1
23	PAFZZ	09780	2164-A	.SHAFT, STRAIGHT	1
24	PAFFF	09780	SA-5145-B	.GEAR, SPUR.....	1
25	PAFZZ	09780	2289-A	.BEARING, SLEEVE.....	1
26	XAFZZ	09780	2173-A	.GEAR.....	1
*27	PAFZZ	71366	TW125	.BEARING, WASHER, THRU.....	1
28	PAFZZ	96906	MS51967-8	.NUT2PLAIN, HEXAGON	2
29	PAFZZ	96906	MS35338-46	.WASHER, LOCK	2
30	XDFZZ	09780	2247-A	.BRACKET, ANGLE.....	1
31	PAFZZ	09780	24280-A1	.BELLOWS, PROTECTION DIPPED NEOPRENE.....	1
32	PAFZZ	96906	MS20995C47	.WIRE, NONELECTRICAL	1
33	PAFZZ	09780	SA-5143-BA	.SHAFT, SHOULDERED	1
34	PAFZZ	96906	MS35756-30	.KEY, WOODRUFF	2
*35	PAFZZ	09780	60388	.SEAL, OIL.....	2
36	PAFZZ	09780	2162-BA	.SHAFT, SHOULDERED	1
37	PAFZZ	09780	24281-A	.WASHER, SEAL BONDED NEOPRENE	2
*39	PAOZZ	96906	MS14314-6Z	.PLUG, PIPE	2
39	PAFZZ	80204	B1821BH038C125N	.SCREW, CAP, HEXAGON	2
40	PAOZZ	96906	MS49006-8	.PLUG, PIPE, MAGNETIC	1
41	XDFZZ	09780	SA-5001-C	.GEAR BOX	1
42	PAFZZ	09780	7386-A	.BUSHING, SLEEVE.....	3
43	PAFZZ	09780	2172-B	.GEAR, SPUR.....	1
44	PAFZZ	09780	5100-125	.RING, RETAINING	2
45	PAOZZ	09780	2171-C	.GEAR, SPUR,	1
46	PAFFF	09780	SA-5010-C	.GEAR, SPUR.....	1
47	PAFZZ	09780	SA-5010-C4	.WASHER, FLAT	1

SECTION II

TM5-3895-367-14&PC01

(1) ITEM NO	(2) SMR CODE	(3) CAGEC	(4) PART NUMBER	(5) DESCRIPTION AND USABLE ON CODE (UOC)	(6) QTY
48	PAFZZ	09780	2289-A	..BEARING, SLEEVE.....	1
49	PAOZZ	96906	MS20913-4	.PLUG, PIPE.....	1
50	PAOZZ	09780	24286	NIPPLE, PIPE 1/2INCH X 6 1/2 INCH.....	1
51	PAOZZ	96906	MS39230-4	ELBOW, PIPE.....	2
52	PAOZZ	09780	24285	NIPPLE, PIPE 1/2 INCH X 5 3/4 INCH.....	1
*53	PAOZZ	80204	B1821BH050C150N	SCREW, CAP, HEXAGON H.....	28
54	PAOZZ	96906	MS51967-15	NUT, PLAIN, HEXAGON.....	28
55	PAOZZ	96906	MS35338-48	WASHER, LOCK.....	28
56	XDOZZ	09780	2212-A1	SUPPORT, ANGLE RIGHT HAND.....	1
57	XDOZZ	09780	2266-B1	SUPPORT, ANGLE RIGHT HAND.....	1
58	XDOZZ	09780	2212-A2	SUPPORT, ANGLE LEFT HAND SIDE.....	1
				OUTBOARD	
58	XDOZZ	09780	2213-A2	SUPPORT, ANGLE LEFT HAND SIDE.....	1
				INBOARD	
59	XDOZZ	09780	2266-B2	SUPPORT, ANGLE LEFT HAND SIDE.11.....	1
60	XDOZZ	09780	2213-A1	SUPPORT, ANGLE RIGHT HAND.....	1
61	PAOZZ	96906	MS27183-17	WASHER, FLAT.....	4

END OF FIGURE

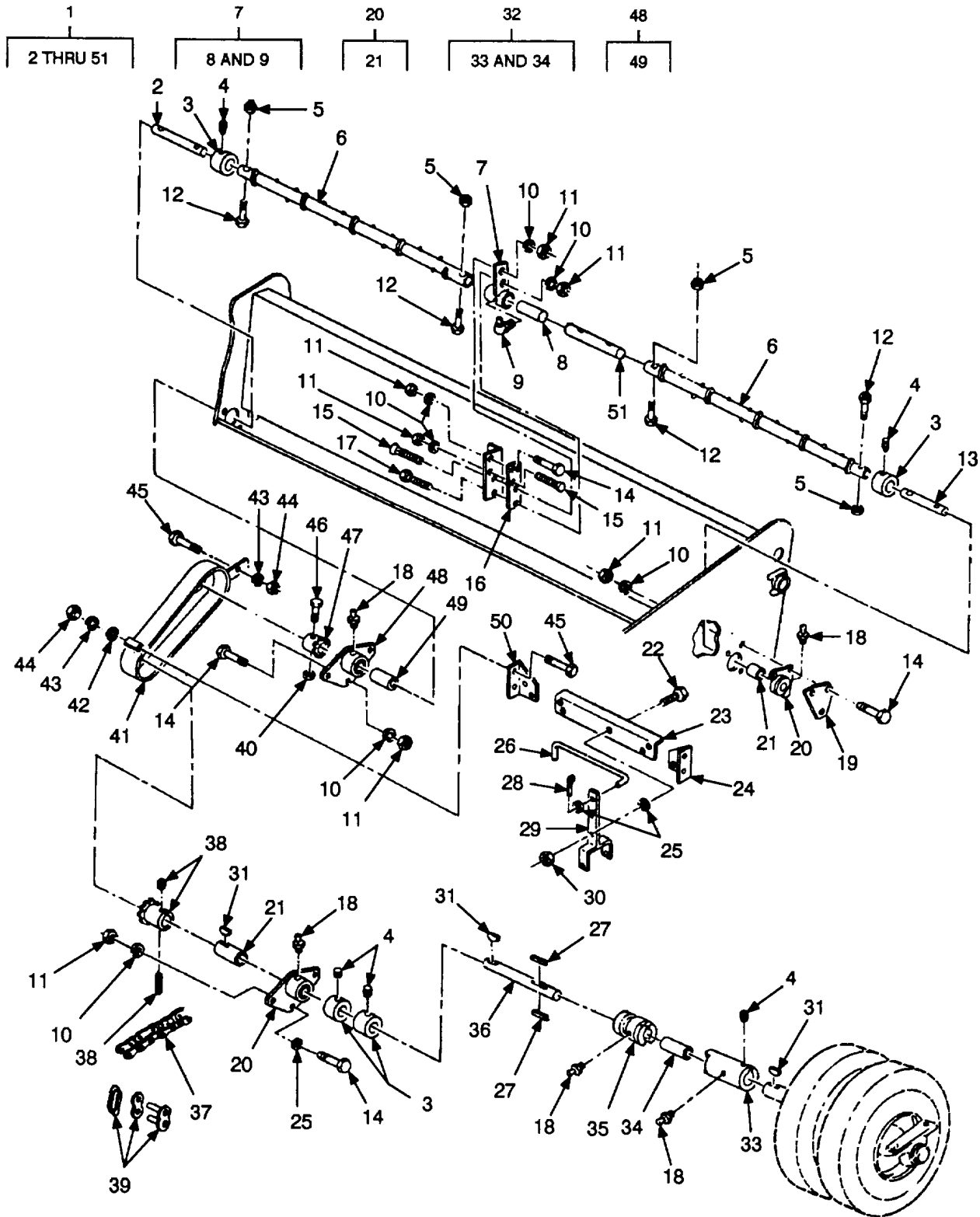

FIGURE 17. AGITATOR ASSEMBLY AND RELATED PARTS.

(1) ITEM NO	(2) SMR CODE	(3) CAGEC	(4) PART NUMBER	(5) DESCRIPTION AND USABLE ON CODE (UOC)	(6) QTY
GROUP 7309 VANE OR SCREW FEEDERS OR CONVEYORS					
FIG. 17 AGITATOR ASSEMBLY AND RELATED PARTS					
1	XDFFF	09780	SA-8445-B	AGITATOR ASSEMBLY	1
2	PFFZZ	09780	2169-A	.PIN, STRAIGHT, HEADLE LEFT HAND.....	1
3	PAFZZ	09780	2248-A	.COLLAR, SHAFT	4
4	PAFZZ	96906	MS51963-105	.SETSCREW	6
5	PAFZZ	96906	MS51943-35	.NUT, SELF-LOCKING, HE	4
6	PFFZZ	09780	SA-8446-B	.SHAFT1SHOULDERED	2
7	PAFFF	09780	SA-22427-B	.BEARING, PLAIN, ROD E	1
8	PAFZZ	09780	2157	.BEARING, SLEEVE.....	1
9	PAOZZ	96906	MS15003-6	.FITTING, LUBRICATION.....	1
10	PAFZZ	96906	M535338-48	.WASHER, LOCK	18
11	PAFZZ	96906	MS51967-14	.NUT, PLAIN, HEXAGON	18
12	PAFZZ	96906	MS90725-67	.SCREW, CAP, HEXAGON H USE GRADE 5.....	4
13	PFFZZ	09780	2168-8	AS SHEAR BOLT .PIN, STRAIGHT, HEADLE RIGHT HAND	1
*14	PAFZZ	80204	818218H050C150N	.SCREW1CAP, HEXAGON H.....	14
15	PAFZZ	96906	MS35754-34	.BOLT, SQUARE NECK	2
16	PAFZZ	09780	2239-A	.BRACKET, MOUNTING.....	1
*17	PAFZZ	80204	B1821BH050C200N	.SCREW, CAP, HEXAGON H.....	1
18	PAOZZ	96906	MS15003-1	.FITTING, LUBRICATION.....	5
19	XDFZZ	09780	8259-B	.PLATE, COVER.....	1
20	PAFFF	09780	SA-22493-B	.BEARING UNIT, PLAIN	2
21	PAFZZ	09780	2157	.BUSHING, SLEEVE.....	1
*22	PAFZZ	80204	B1821BH050C175N	.SCREW, CAP, HEXAGON H.....	1
23	PFFZZ	09780	2267-B	.BRACKET, MOUNTING CLUTCH, RIGHT HAND.....	1
24	PFFZZ	09780	2229-B	.BRACKET, ANGLE RIGHT HAND.....	1
25	PAFZZ	96906	MS27183-17	.WASHER, FLAT	6
26	PFFZZ	09780	2268-B	.ROD, STRAIGHT, HEADLE.....	1
27	PAFZZ	09780	2287	.KEY, SQUARE.....	2
28	PAFZZ	96906	MS24665-495	.PIN, COTTER	1
29	PFFZZ	09780	SA-8032-A	.SHIFTER FORK.....	1
30	PAFZZ	96906	MS51943-39	.NUT, SELF-LOCKING, HE	1
31	PAFZZ	96906	MS35756-30	.KEY, WOODRUFF	3
32	PAFFF	09780	SA-5352-B	.BUSHING, SLEEVE.....	1
33	XAFZZ	09780	5353	.CLUTCH, FEMALE AGITA	1
34	PAFZZ	71041	B2026-16	.BEARING, SLEEVE.....	1
35	PAFZZ	09780	5354-8	.CLUTCH1POSITIVE	1
36	PFFZZ	09780	SA-5421-B	.SHAFT, STRAIGHT AGITATOR DRIVE.....	1
37	PAOZZ	09780	SA-8445-C-22	.CHAIN, ROLLER	1
38	PAFZZ	09780	2160-A	.SPROCKET WHEEL INCLUDES SETSCREW	1
39	PAOZZ	09780	SA-8445-C-23	.LINK, CHAIN, CONNECTI CHAIN.....	1
40	PAFZZ	96906	MS35690-504	CONNECTING .NUT, PLAIN, HEXAGON	1
*41	PFOZZ	09780	SA-5147-C	.GUARD, MECHANICAL DR CHAIN, FEED..... ROLLER	1
42	PAOZZ	96906	MS27183-17	.WASHER, FLAT	1
43	PAOZZ	96906	MS35338-48	.WASHER, LOCK	2

SECTION II

TM5-3895-367-14&PC01

(1) ITEM NO	(2) SMR CODE	(3) CAGEC	(4) PART NUMBER	(5) DESCRIPTION AND USABLE ON CODE (UOC)	(6) QTY
44	PAOZZ	96906	MS51967-14	.NUT, PLAIN, HEXAGON,	2
*45	PAOZZ	80204	81821SH050C150N	.SCREW, CAP, HEXAGON H.,.....	2
*46	PAFZZ	80204	B1821BH038C300N	.SCREW, CAP, HEXAGON H.....	1
47	PAFZZ	09780	2161-A	.SPROCKET WHEEL	1
48	PAFFF	09780	SA-22492-B	.BUSHING, SLEEVE.....	1
49	PAFZZ	09780	2157	.BEARING, SLEEVE.....	1
50	PFFZZ	09780	2230-B	.BRACKET, ANGLE CLUTCH LEFT HAND.....	1
51	PFFZZ	09780	2167-A	.PIN, STRAIGHT, HEADLE.....	1

END OF FIGURE

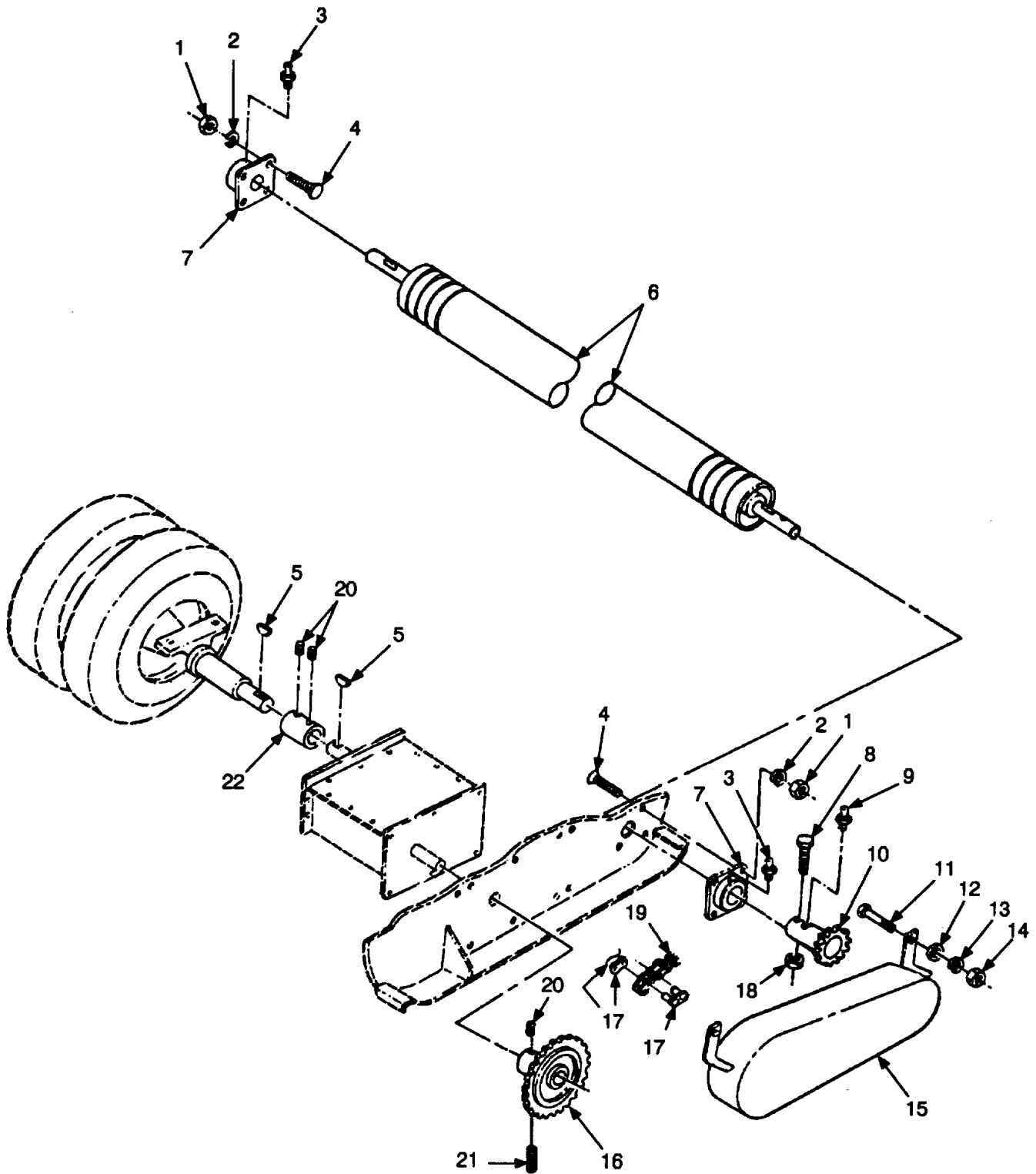

FIGURE 18. FEED ROLL AND RELATED PARTS.

SECTION II

TM5-3895-367-14&PC01

(1) ITEM NO	(2) SMR CODE	(3) CAGEC	(4) PART NUMBER	(5) DESCRIPTION AND USABLE ON CODE (UOC)	(6) QTY
GROUP 7311 FEEDING OR CONVEYOR SHAFT					
FIG. 18 FEED ROLL AND RELATED PARTS					
1	PAFZZ	96906	MS51967-14	NUT, PLAIN, HEXAGON	8
2	PAFZZ	96906	MS35338-48	WASHER, LOCK	8
3	PAFZZ	96906	MS15003-6	FITTING, LUBRICATION	2
4	PAFZZ	96906	MS35754-34	BOLT, SQUARE NECK	8
5	PAFZZ	96906	MS35756-30	KEY, WOODRUFF	2
6	PFFZZ	09780	SA-8460-DW	FEEDER, AGGREGATE	1
7	PAFZZ	09780	24221	BEARING, SLEEVE	2
8	PAFZZ	80204	B121BH038C300N	SCREW, CAP, HEXAGON H.....	1
9	PAFZZ	96906	MS15003-1	FITTING, LUBRICATION	1
10	PAFZZ	09780	5381-C	SPROCKET WHEEL FEED ROLL DRIVE	1
11	PAOZZ	80204	B18218H050C150N	SCREW, CAP, HEXAGON H.....	1
12	PAOZZ	96906	MS27183-17	WASHER, FLAT	1
13	PAOZZ	96906	MS35338-48	WASHER, LOCK	1
14	PAOZZ	96906	MS51967-14	NUT, PLAIN, HEXAGON	1
*15	PFOZZ	09780	SA-5146-C	GUARD, MECHANICAL DR	1
16	PAOZZ	09780	SA-2159-A	SPROCKET WHEEL FEED ROLL DRIVE	1
17	PAOZZ	09780	24225	LINK, CHAIN, CONNECTI CHAIN	1
CONNECTING					
18	PAFZZ	96906	MS51967-8	NUT, PLAIN1HEXAGON	1
19	PAOZZ	09780	24224	CHAIN, ROLLER FEED ROLL DRIVE.....	1
20	PAOZZ	96906	MS51963-105	SETSCREW	3
21	PAOZZ	96906	MS51963-69	SETSCREW	1
22	XDOZZ	09780	24223-A-1	COUPLING, PIPE	1

END OF FIGURE

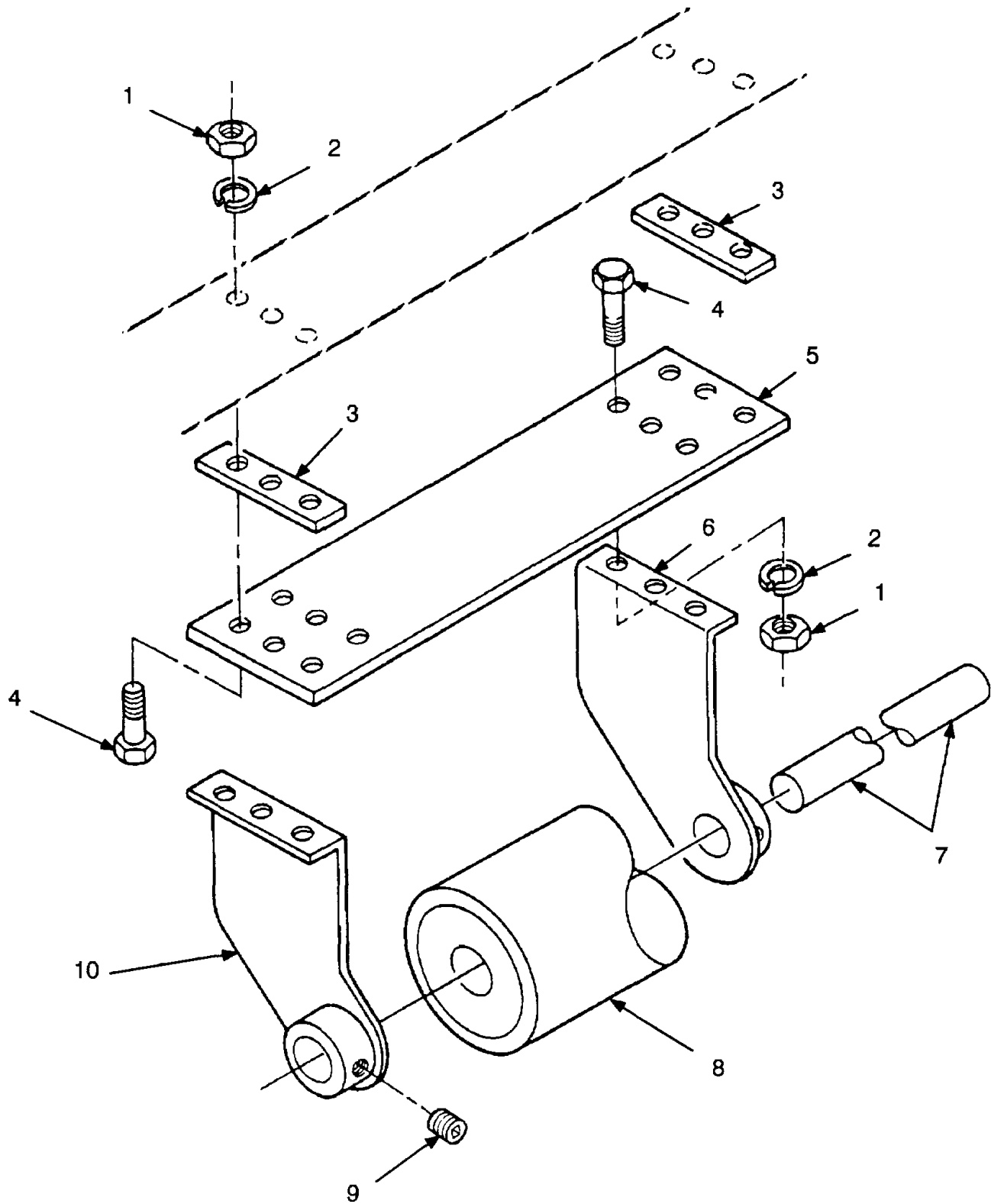

FIGURE 19. BALANCE ROLLER AND RELATED PARTS.

(1) ITEM NO	(2) SMR CODE	(3) CAGEC	(4) PART NUMBER	(5) DESCRIPTION AND USABLE ON CODE (UOC)	(6) QTY
GROUP 7311 FEEDING OR CONVEYOR SHAFT					
FIG. 19 BALANCE ROLLER AND RELATED PARTS					
1	PAOZZ	96906	MS51967-20	NUT, PLAIN, HEXAGON	12
2	PAOZZ	96906	MS35338-50	WASHER, LOCK	12
3	PAOZZ	09780	10329-A	BRACKET, MOUNTING.....	2
*4	PAOZZ	80204	B1821BH063C200N	SCREW, CAP, HEXAGON H.....	12
5	PAOZZ	09780	10330-A	PLATE, MOUNTING, FLAT	1
6	PAOZZ	09780	SA-10302-B1	BRACKET, MOUNTING FORWARD SIDE.....	1
7	PAOZZ	09780	SA-15451-A	SHAFT, STRAIGHT	1
8	PAOZZ	09780	SA-10303-B	ROLLER, CONVEYOR	1
9	PAOZZ	96906	MS51963-105	SETSCREW	2
10	PAOZZ	09780	SA-10302-B2	BRACKET, MOUNTING REAR SIDE	1

END OF FIGURE

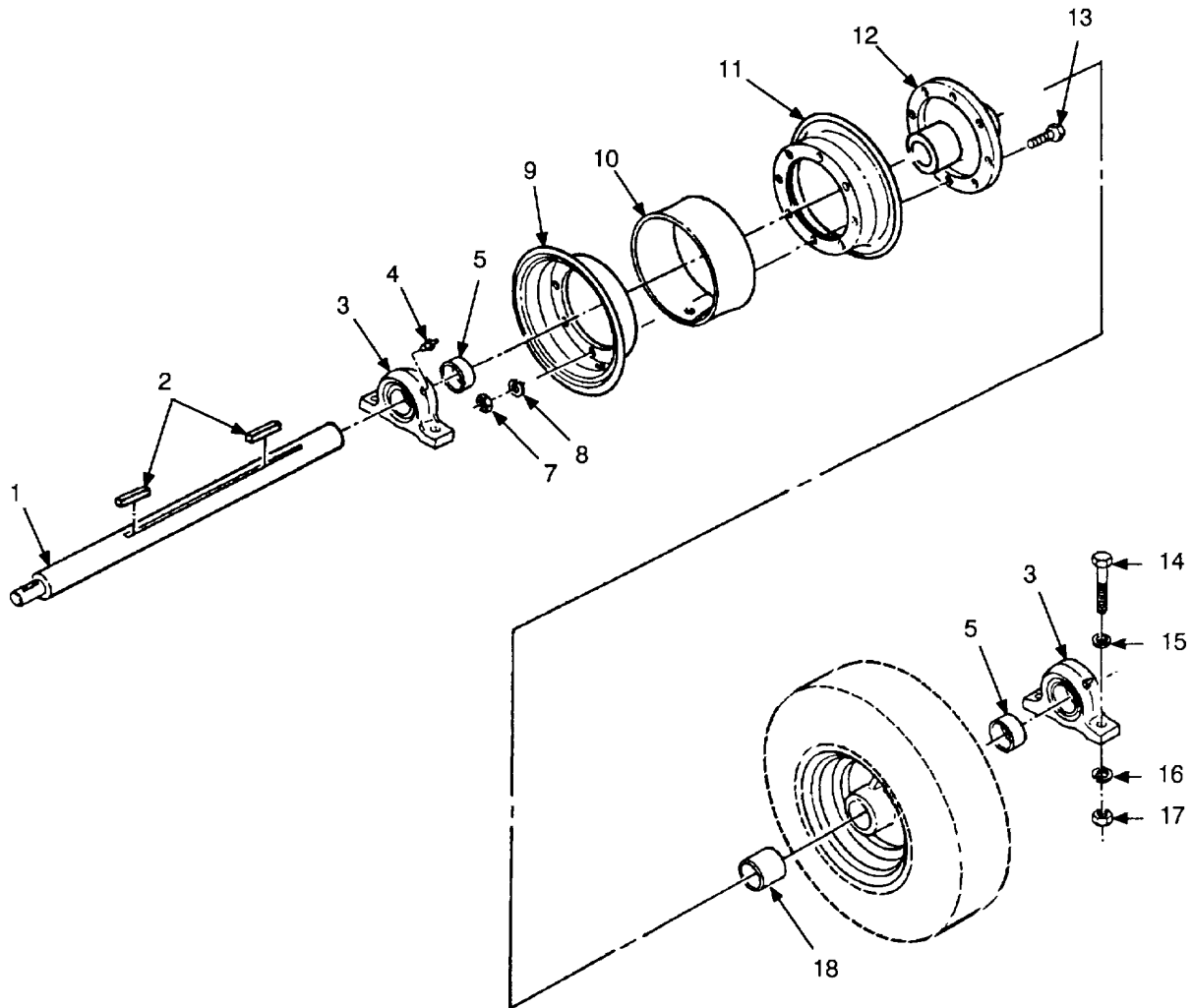
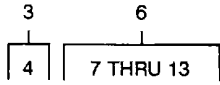

FIGURE 20. TRACTION WHEEL ASSEMBLY AND RELATED PARTS.

SECTION II

TM5-3895-367-14&PC01

(1) ITEM NO	(2) SMR CODE	(3) CAGEC	(4) PART NUMBER	(5) DESCRIPTION AND USABLE ON CODE (UOC)	(6) QTY
GROUP 7315 TRACTION DRIVE					
FIG, 20 TRACTION WHEEL ASSEMBLY AND RELATED PARTS					
1	PFOZZ	09780	2263-A	SHAFT, SHOULDERED,	1
2	XDOZZ	09780	2285	KEY, SQUARE 1/2 INCH SQUARE X 3-1/2	2
				INCHES LONG	
3	PAOZZ	09780	24222	HOUSING, BEARING UNI BEARING.....	2
4	PAOZZ	96906	MS15003-1	.FITTING , LUBRICATION.....	1
5	XDOZZ	09780	9617	SPACER, WHEEL 2 INCH STANDARD PIPE	2
				X 1-7/8 INCHES LONG	
6	PAOOO	09780	SA-8719-C	WHEEL, PNEUMATIC TIR	2
7	PAOZZ	96906	MS35690-724	.NUT, PLAIN, HEXAGON	8
8	PAOZZ	96906	MS35338-47	.WASHER, LOCK	8
9	XDOZZ	09780	6834	.RIM	1
10	PAOZZ	36024	8446821	.FLAP, INNER TUBE, PNE.....	1
11	XDOZZ	09780	6835	.RIM	1
12	XDOZZ	09780	SA-6804-C	.HUB, WHEEL	1
13	PAOZZ	96906	MS90727-89	.SCREW, CAP, HEXAGON H.....	8
*14	PAOZZ	80204	B1821BH050C250N	SCREW, CAP, HEXAGON H.....	4
15	PAOZZ	96906	MS27183-17	WASHER, FLAT	4
16	PAOZZ	96906	MS35338-48	WASHER, LOCK	4
17	PAOZZ	96906	MS51967-14	NUT, PLAIN, HEXAGON	4
18	XDOZZ	09780	2156	SPACER, WHEEL 2 INCH STANDARD PIPE	1
				X 3-7/8 INCHES LONG	

END OF FIGURE

SECTION II

TM5-3895-367-14&PC01

(1) ITEM NO	(2) SMR CODE	(3) CAGEC	(4) PART NUMBER	(5) DESCRIPTION AND USABLE ON CODE (UOC)	(6) QTY
-------------------	--------------------	--------------	-----------------------	---	------------

GROUP 95 GENERAL USE STANDARDIZED
PARTS
GROUP 9501 BULK MATERIAL
FIG. BULK

1	PAOZZ	09780	24296	WIRE, ELECTRICAL	V
---	-------	-------	-------	------------------------	---

END OF FIGURE

BULK-1

CROSS- REFERENCE-INDEXES
NATIONAL STOCK NUMBER INDEX

STOCK NUMBER	FIG.	ITEM	STOCK NUMBER	FIG.	ITEM
5310-00-011-5093	16	2	5310-00-167-0826	8	1
5306-00-021-8150	9	4	4730-00-172-0034	17	9
	17	15		18	3
	18	4	5315-00-187-9412	16	11
4730-00-050-4207	9	28	5315-00-187-9567	9	8
4730-00-050-4208	15	1		9	21
	17	18	4730-00-138-3515	16	49
	18	9	9905-00-205-2795	11	8
	20	4	5310-00-209-0965	20	8
2610-00-050-9870	5	2	3120-00-222-1545	17	32
5305-00-054-9271	15	5	3120-00-222-1548	17	48
5935-00-059-2841	2	3	5306-00-226-4831	16	12
5310-00-061-4651	13	2	5315-00-234-1664	17	28
5305-00-068-0500	11	9	5310-00-234-7815	20	7
5305-00-068-0510	6	8	4730-00-253-4414	16	51
	9	11	5305-00-253-5618	12	2
5305-00-068-0511	15	25	5305-30-269-3211	11	14
	16	39	5305-30-269-3217	17	12
5305-00-071-2067	6	3	5365-00-281-6623	16	44
	9	30	5315-00-298-1499	14	3
	14	11	3120-00-353-1406	16	19
	16	13		16	25
5305-00-071-2069	7	8		16	48
	14	7	5310-00-407-9566	16	7
	15	12	5310-00-409-3333	9	29
	16	53	3120-00-410-6433	16	27
	17	14	2530-00-434-0647	3	7
	17	45	2530-00-484-0648	3	8
	18	11	3049-00-484-0740	20	1
5305-00-071-2070	3	2	5310-00-488-3389	14	9
	17	22		17	30
5305-00-071-2071	15	28	5330-00-498-4589	16	35
	17	17	2640-00-535-7509	20	10
5305-00-071-2073	9	19	2610-00-540-4719	5	1
	20	14	5305-00-543-2866	11	19
5305-30-071-2077	15	13	5305-00-543-4372	16	3
5305-00-071-2081	8	5	9505-00-555-8648	16	32
5305-00-071-2510	13	14	5310-30-582-5965	11	10
3120-00-079-8142	17	34		13	9
5310-00-090-6004	11	20	5310-00-584-5272	3	13
	15	21		6	11
2610-00-089-5997	5	3		7	9
3110-00-100-0515	4	7		8	2
3110-00-100-0544	4	4		9	3
3110-00-100-3541	4	2		9	16
3110-00-142-4355	4	8		10	6
5940-00-143-4777	2	5		11	17
6240-00-155-7784	1	10		14	2
5305-00-165-8036	11	2		15	3
5305-00-165-8074	10	3		16	14

CROSS- REFERENCE-INDEXES
NATIONAL STOCK NUMBER INDEX

STOCK NUMBER	FIG.	ITEM	STOCK NUMBER	FIG.	ITEM	
5310-00-584-5272	16	55	5310-00-768-0318	9	15	
	17	10		10	7	
	17	43		11	16	
	18	2		14	1	
	18	13		15	2	
5310-00-534-7888	20	16	17	11		
	6	22	17	44		
	16	22	18	1		
5315-00-616-5506	16	34	18	14		
	17	31	20	17		
5310-00-637-9541	18	5	5305-00-782-9489	13	13	
	6	18	5310-00-809-5997	6	9	
	9	12		11	18	
	9	23		14	10	
	11	5		15	4	
	11	13		16	61	
	15	20		17	25	
	16	29		17	42	
	9	26		18	12	
	5305-00-638-8920	20	13	20	15	
	5305-00-709-8539	18	21	5310-00-809-8541	9	38
	5305-00-723-9381	13	8	5310-00-820-6653	3	5
	5305-00-724-5382	17	4		7	3
		13	20		19	2
		19	9	5305-00-821-3869	15	27
5305-00-724-7222	3	4	5310-00-823-8803	3	12	
	19	4		6	14	
5305-00-724-7224	3	11		13	3	
	7	6	5315-00-839-5822	6	15	
5305-00-725-0163	6	23	5315-00-842-3044	7	13	
5305-00-725-2317	15	24	5305-00-846-5703	17	46	
5310-00-732-0558	6	17		18	8	
	9	22	5310-00-880-7744	10	10	
	11	12	5310-00-889-2528	1	7	
	15	19	5305-00-914-7648	16	21	
	16	28	5940-00-926-0085	2	6	
	18	18	5310-00-935-9021	13	12	
	16	5		17	5	
	5330-00-760-7404	16	54	5310-00-982-4949	16	8
	5310-00-761-3706	1	8	5310-00-998-0608	14	4
	5310-00-761-6882	11	11	5315-01-019-9306	15	17
13		10	5310-01-064-3422	17	40	
3		6	6220-01-068-8504	1	2	
5310-00-763-8920	7	4	6220-01-071-1495	1	2	
	19	1	5315-01-081-9991	10	8	
5310-00-768-0318	3	14	5310-01-C88-2490	11	6	
	6	10	6220-01-095-2616	1	4	
	7	10	4730-01-135-8310	16	40	
	3	3	7690-01-143-6993	12	10	
	9	2	5975-01-148-4589	1	9	

CROSS- REFERENCE-INDEXES
NATIONAL STOCK NUMBER INDEX

STOCK NUMBER	FIG.	ITEM	STOCK NUMBER	FIG.	ITEM
5305-01-152-4655	1	3	3010-31-340-0447	13	6
5330-01-154-5214	1	5	3020-01-340-0469	17	38
5315-01-156-5229	6	5	3895-01-340-0513	18	6
7690-01-171-9522	12	11	2510-01-340-1456	7	2
3010-01-175-9722	9	24	2530-01-340-1636	4	10
5306-01-201-3336	4	5	3020-01-340-1642	17	47
5305-01-242-1782	6	20	304C-01-340-1789	13	1
3040-01-291-9579	15	8	3040-01-340-4771	15	9
5310-01-305-4341	9	27	5340-01-340-7165	7	1
4730-01-338-2227	16	38	6220-01-340-7530	1	1
3030-31-339-0409	15	22	5310-01-340-8468	16	37
	15	23	3040-01-340-8779	15	7
3130-01-339-1345	18	7	3120-01-340-9932	17	8
5330-01-339-1443	16	17		17	21
3120-31-339-1509	16	16		17	49
	16	42	3040-01-341-0188	17	26
3130-01-339-1553	17	20	5315-01-341-0815	17	27
3040-01-339-1577	16	23	3040-01-341-1470	13	7
3040-01-339-1579	16	10	6220-01-341-3257	1	1
3040-01-339-1579	16	36	5310-01-341-6449	3	9
3020-01-339-1627	16	46	4010-01-341-6474	17	39
3020-31-339-1628	16	24	4010-D1-341-6475	18	17
3020-31-339-1629	16	45	5360-01-341-8665	13	4
3010-01-339-1647	16	18	3120-01-341-8993	15	10
3020-01-339-1668	13	10	5315-01-341-9643	17	2
4730-01-339-2157	16	50	5340-01-341-9663	1	11
4730-01-339-2158	16	52	5310-01-342-0195	9	40
2540-01-339-2327	7	5	5310-01-342-0196	9	39
5340-01-339-3313	16	6	5340-01-342-0362	17	23
5306-01-339-3919	9	35	5340-01-342-0531	16	31
5306-01-339-4149	9	20	3120-31-342-3138	16	15
4010-01-339-4216	7	11	5340-01-342-4992	17	24
2520-01-339-6314	16	20	5365-01-342-8610	9	17
3040-01-339-7960	13	11	9905-01-342-9013	12	4
3040-01-339-8569	17	36	6150-01-343-1250	2	1
3040-01-339-8573	16	33	5340-01-343-1794	17	50
3830-01-339-8588	9	6	9905-01-343-2076	12	7
2520-01-339-8599	17	35	9905-01-343-2085	12	5
2520-01-339-8657	17	29	9905-01-343-2390	12	8
2520-01-339-8658	16	9	9905-31-343-3843	12	6
2540-01-339-8671	9	13	9905-01-343-4407	12	3
3020-01-339-8679	18	16	5330-01-345-2316	4	1
4310-01-339-8714	17	6	3040-01-345-3951	17	3
5315-01-339-8303	3	10	5315-01-345-6743	17	13
5365-01-339-8901	9	33	2530-01-346-0106	20	6
3130-01-339-8965	20	3	5310-01-346-0227	4	11
5315-01-340-0347	17	51	5310-01-346-0394	16	47
3020-01-340-0359	18	19	3120-01-346-1504	17	7
3020-01-340-0360	17	37	5306-01-346-2892	9	34
5340-01-340-0381	13	5	5306-01-346-2893	6	21

**CROSS- REFERENCE-INDEXES
NATIONAL STOCK NUMBER INDEX**

STOCK NUMBER	FIG.	ITEM	STOCK NUMBER	FIG.	ITEM
5360-01-346-2899	6	13			
5360-01-346-2900	9	7			
5365-01-346-2930	9	37			
5365-01-346-2944	9	18			
6145-01-346-3447	BULK	1			
5315-01-346-3463	10	9			
5340-01-346-3639	6	12			
5340-01-346-3654	3	1			
5340-01-346-3655	19	3			
5340-01-346-3893	15	16			
5340-01-346-4294	17	16			
6240-01-346-8214	1	6			
3130-01-348-3793	15	11			
3020-01-348-3865	16	43			
9905-01-349-4459	12	1			
5340-01-355-5261	19	6			
5340-01-355-5262	19	10			
3040-01-355-5987	19	7			
3830-01-355-6012	8	4			
5340-01-355-6874	19	5			
3910-01-355-7807	19	8			
9905-01-359-3346	12	9			
3020-01-361-5158	17	41			
3020-01-361-5159	18	15			
2530-01-366-7047	4	9			

**NATIONAL STOCK NUMBER AND PART NUMBER INDEX
PART NUMBER INDEX**

CAGEC	PART NUMBER	STOCK NUMBER	FIG.	ITEM
88044	AN415-6	5315-01-081-9991	10	8
88044	AN960-1216	5310-00-167-0826	8	1
80204	B1821BH025C175N	5305-00-071-2510	13	14
80204	B1821BH031C150N	5306-00-226-4831	16	12
80204	B1821BH038C075N	5305-00-543-4372	16	3
80204	B18218H038C100N	5305-00-068-0510	6	8
			9	11
80204	B1821BH038C125N	5305-00-068-0511	15	25
			16	39
80204	B18218H038C150N	5305-00-725-2317	15	24
80204	B1821BH038C175N	5305-00-821-3869	15	27
80204	B1821BH038C200N	5305-00-782-9489	13	13
80204	B1821BH038C225N	5305-00-638-8920	9	26
80204	B1821BH038C250N	5305-00-543-2866	11	19
80204	B1821BH038C300N	5305-00-846-5703	17	46
			18	8
80204	B1821BH050C125N	5305-00-071-2067	6	3
			9	30
			14	11
			16	13
80204	B1821BH050C150N	5305-00-071-2069	7	8
			14	7
			15	12
			16	53
			17	14
			17	45
			18	11
80204	B1821BH050C175N	5305-00-071-2070	3	2
			17	22
80204	B18218H050C200N	5305-00-071-2071	15	28
			17	17
80204	B1821BHO50C250N	5305-00-071-2073	9	19
			20	14
80204	B1821BH050C350N	5305-00-071-2077	15	13
80204	B1821BH050C450N	5305-00-071-2081	8	5
80204	B1821BH063C200N	5305-00-724-7222	3	4
			19	4
80204	B1821BH063C250N	5305-00-724-7224	3	11
			7	6
71041	B2026-16	3120-00-079-8142	17	34
10988	L32257	6240-00-155-7784	1	10
81349	MIL-T-12459/CLMS /SB/9.00-16/D/MS	2610-00-540-4719	5	1
96906	MS14314-6Z	4730-01-338-2227	16	38
96906	MS15001-4	4730-00-050-4207	9	28
96906	MS15003-1	4730-00-050-4208	15	1
			17	18
			18	9
			20	4
96906	MS15003-6	4730-00-172-0034	17	9
			1	3

**NATIONAL STOCK NUMBER AND PART NUMBER INDEX
PART NUMBER INDEX**

CAGEC	PART NUMBER	STOCK NUMBER	FIG.	ITEM
96906	MS171590	5315-01-019-9306	15	17
96906	MS17990-827	5315-01-156-5229	6	5
96906	MS20913-4	4730-00-188-3515	16	49
96906	MS20995C47	9505-00-555-8643	16	32
96906	MS21318-27	5305-00-253-5618	12	2
96906	MS24665-283	5315-00-842-3044	7	13
96906	MS24665-353	5315-00-839-5822	6	15
96906	MS24665-360	5315-00-298-1499	14	3
96906	MS24665-495	5315-00-234-1664	17	28
96906	MS24665-500	5315-00-137-9567	9	3
			9	21
96906	MS24665-653	5315-00-187-9412	16	11
96906	MS25036-157	5940-00-143-4777	2	5
96906	MS27040-11	5310-00-932-4949	16	4
96906	MS27133-14	5310-00-080-6004	11	20
			15	21
96906	MS27133-17	5313-00-809-5997	6	9
			11	18
			14	10
			15	4
			16	61
			17	25
			17	42
			13	12
			20	15
96906	MS27133-21	5310-00-823-8603	3	12
			6	14
			13	3
96906	MS27133-27	5310-00-809-8541	9	38
96906	MS35338-44	5310-00-532-5965	11	10
			13	9
96906	MS35333-45	5310-00-407-9566	16	7
96906	MS35338-46	5310-00-637-9541	6	18
			9	12
			9	23
			11	5
			11	13
			15	20
			16	29
96906	MS35338-47	5310-00-209-0965	20	8
96906	MS35338-43	5310-00-534-5272	3	13
			6	11
			7	9
			8	2
			9	3
			9	16
			10	6
			11	17
			14	2
			15	3
			16	14

**NATIONAL STOCK NUMBER AND PART NUMBER INDEX
PART NUMBER INDEX**

CAGEC	PART NUMBER	STOCK NUMBER	FIG.	ITEM
96906	MS35338-48	5310-00-584-5272	16	55
			17	10
			17	43
			18	2
			18	13
			20	16
96906	MS35338-50	5310-00-820-6653	3	5
			7	3
			19	2
96906	MS35338-51	5310-00-584-7988	6	22
			16	22
96906	MS35338-65	5310-00-011-5093	16	2
96906	MS35387-1	9905-00-205-2795	11	8
96906	MS35389-84	2610-00-050-9870	5	2
96906	MS35425-74	5310-01-088-2490	11	6
96906	MS35690-504	5310-01-064-3422	17	40
96906	MS35690-724	5310-00-234-7915	20	7
96906	MS35692-61	5310-00-998-0608	14	4
96906	MS35754-34	5306-00-021-3150	9	4
			17	15
96906	MS35756-30	5315-00-616-5506	18	4
			16	34
			17	31
96906	MS39230-4	4730-00-253-4414	18	5
			16	51
			1	7
			16	40
			10	3
			6	20
			13	12
			17	5
96906	MS51943-39	5310-00-438-3889	14	9
			17	30
96906	MS51943-43	5310-00-061-4651	13	2
			9	29
96906	MS51943-45	5310-00-409-3333	9	27
96906	MS51943-49	5310-01-335-4341	15	5
96906	MS51955-36	5305-00-054-9271	13	8
96906	MS51963-105	5305-00-724-5382	13	8
			17	4
			19	20
			19	9
96906	MS51963-140	5305-00-725-0163	6	23
96906	MS51963-69	5305-00-723-9381	13	21
96906	MS51967-14	5310-00-763-0313	3	14
			6	10
			7	10
			8	3
			9	2
			9	15
			10	7
			11	16

**NATIONAL STOCK NUMBER AND PART NUMBER INDEX
PART NUMBER INDEX**

CAGEC	PART NUMBER	STOCK NUMBER	FIG.	ITEM
96906	MS51967-14	5310-00-768-0318	14	1
			15	2
			17	11
			17	44
			18	1
			18	14
96906	MS51967-15	5310-00-761-3706	20	17
96906	MS51967-2	5310-00-761-6882	16	54
96906	MS51967-20	5310-00-763-8920	1	3
			11	11
			13	10
96906	MS51967-5	5310-00-880-7744	3	6
			7	4
			19	1
96906	MS51967-8	5310-00-732-0558	10	10
96906	MS51967-8	5310-00-732-0558	6	17
			9	22
			11	12
			15	19
			16	28
			18	18
			2	3
			11	9
			11	14
			17	12
96906	MS75020-1	5935-00-059-2841	16	21
96906	MS90725-3	5305-00-068-0500	20	13
96906	MS90725-60	5305-00-269-3211	6	24
96906	MS90725-67	5305-00-269-3217	13	11
96906	MS90727-185	5305-00-914-7648	19	6
96906	MS90727-89	5305-00-709-3539	19	10
09780	SA-10074-5		19	8
09780	SA-10186-C	3040-01-339-7960	19	7
09780	SA-10302-B1	5340-01-355-5261	6	2
09780	SA-10302-B2	5340-01-355-5262	3	4
09780	SA-10303-B	3910-01-355-7807	3	3
09780	SA-15451-A	3040-01-355-5987	3	7
09780	SA-19668-D		7	5
09730	SA-19672-D		11	15
09780	SA-20232-0	3330-01-355-6012	10	5
09780	SA-20298-D		10	4
09780	SA-20301-C	2530-00-484-0647	7	14
09790	SA-20306-C	2530-00-484-0643	14	13
09780	SA-20313-B	2540-01-339-2327	18	16
09780	SA-20356-B		15	9
09780	SA-20402-A		9	6
09780	SA-20403-A		17	7
09780	SA-20434-A	4010-01-339-4216		
09780	SA-20434-A2			
09780	SA-20434-A3			
39780	SA-2146-C			
09780	SA-2159-A	3020-01-339-3679		
09780	SA-2178-A	3040-01-340-4771		
09780	SA-22329-3	3330-01-339-8588		
09780	SA-22427-B	3120-01-346-1504		

**NATIONAL STOCK NUMBER AND PART NUMBER INDEX
PART NUMBER INDEX**

CAGEC	PART NUMBER	STOCK NUMBER	FIG.	ITEM
09780	SA-22492-B	3120-00-222-1548	17	48
09780	SA-22493-B	3130-31-339-1558	17	20
09780	SA-24220-B-1	6150-01-343-1250	2	1
09780	SA-24220-B-2	6220-01-340-7530	1	1
09780	SA-24220-B-3	6220-01-341-3257	1	1
09780	SA-5001-C		16	41
09780	SA-5002-D		16	1
09780	SA-5010-C	3020-01-339-1627	16	46
09780	SA-5010-C4	5310-01-346-0394	16	47
09780	SA-5011-B	3010-01-339-1647	16	18
097980	SA-5137-B		14	5
09780	SA-5139-B	3120-01-341-8993	15	10
09780	SA-5140-B	2520-01-339-8658	16	9
09780	SA-5143-BA	3040-01-339-8573	16	33
09780	SA-5145-B	3020-01-339-1628	16	24
09780	SA-5146-C	3020-01-361-5159	18	15
09780	SA-5147-C	3020-01-361-5158	17	41
09780	SA-5150-B		9	5
09780	SA-5203-B	5340-01-339-3313	16	6
09780	SA-5352-B	3120-00-222-1545	17	32
09780	SA-5421-8	3040-01-339-8569	17	36
09780	SA-6804-C		20	12
09780	SA-6946-C	3120-01-342-3133	16	15
09780	SA-8032-A	2520-01-339-8657	17	29
09780	SA-3326-0		9	1
09780	SA-8433-B		15	15
09780	SA-8445-B		17	1
09780	SA-8445-C-22	3020-01-340-0360	17	37
09780	SA-9445-C-23	4010-01-341-6474	17	39
09780	SA-3446-B	4310-01-339-8714	17	6
09780	SA-8446-D		15	6
0978C	SA-3450-8	3040-01-291-9579	15	8
09780	SA-8460-DW	3895-01-340-0513	18	6
09780	SA-8719-C	2530-01-346-0106	20	6
09780	S4-8854-B	3040-01-340-1789	13	1
09780	SA-9338-A		7	7
09780	SA-9340-A	2510-01-340-1456	7	2
09780	SA-9783-B		14	12
58752	S32-23	7690-01-143-6993	12	10
71366	TW125	3120-00-410-6433	16	27
81834	10-7056-01	5975-01-148-4589	1	9
06495	101-2-101	3010-01-175-9722	9	24
09780	10329-A	5340-01-346-3655	19	3
09780	10330-A	5340-01-355-6374	19	5
09780	10349-5		9	31
1DF03	14125A	3110-00-142-4355	4	8
09780	19194-A	5330-01-339-1448	16	17
21450	193031	5305-00-165-8036	11	2
09780	19672-DA		6	4
09780	19672-DB		6	16
09780	19672-DC		6	7

**NATIONAL STOCK NUMBER AND PART NUMBER INDEX
PART NUMBER INDEX**

CAGEC	PART NUMBER	STOCK NUMBER	FIG.	ITEM
09780	19672-DD		6	19
09780	19672-DE		6	6
09780	19672-014	5340-01-346-3639	6	12
09780	19672-D15	5360-01-346-2399	6	13
09780	20300-A	5340-01-346-3654	3	1
09780	20371-A	9905-01-343-2076	12	7
09780	20444-B		15	18
09780	20491-A		11	1
09780	20492-A		11	4
09780	20510-A1	3030-01-339-0409	15	23
09780	20517-A	9905-01-343-4407	12	3
09730	20518-A	9905-01-342-9013	12	4
09780	2122-A	3130-01-348-3793	15	11
09780	2123-A		15	14
09730	2124-3		14	6
09780	2126-A		14	3
09730	2127	5365-01-339-3901	9	33
09790	2130-A		9	32
09780	2131-A		9	36
09780	2156		20	18
09780	2157	3120-01-340-9932	17	8
			17	21
			17	49
09730	2160-A	3020-01-340-0469	17	38
09780	2161-A	3020-01-340-1642	17	47
09780	2162-BA	3040-31-339-1579	16	36
09780	2164-A	3040-01-339-1577	16	23
09780	2167-A	5315-01-340-0347	17	51
09780	2163-3	5315-01-345-6743	17	13
09780	2169-A	5315-01-341-9643	17	2
09780	2171-C	3020-01-339-1629	16	45
09780	2172-3	3020-01-348-3865	16	43
09780	2173-A		16	26
09780	2176-A		9	9
09730	2177-A	3040-01-340-8779	15	7
09780	2192-A	5365-01-346-2944	9	18
09780	2193-A	5365-01-342-8610	9	17
09790	2194-A	5306-01-339-3919	9	35
09730	2195	5306-01-346-2392	9	34
09780	2196-3	5306-01-339-4149	9	20
09780	2202-A	5360-01-346-2900	9	7
09780	2212-A1		16	56
09780	2212-A2		16	58
09780	2213-A1		16	60
09780	2213-A2		16	53
09780	2216-C		16	4
09780	2225-A	3040-01-339-1578	16	10
09780	2227-A	3040-01-341-1470	13	7
09780	2229-3	5340-01-342-4992	17	24
09780	2230-B	5340-01-343-1794	17	50
09780	2239-A	5340-01-346-4294	17	16

**NATIONAL STOCK NUMBER AND PART NUMBER INDEX
PART NUMBER INDEX**

CAGEC	PART NUMBER	STOCK NUMBER	FIG.	ITEM
09780	2247-A		16	30
09780	2248-A	3040-01-345-3951	17	3
09780	2260-A		15	26
09780	2263-A	3040-00-484-0740	20	1
09780	2266-B1		16	57
09780	2266-32		16	59
09780	2267-B	5340-01-342-0362	17	23
09780	2268-B	3040-01-341-0188	17	26
09780	2285		20	2
09780	2287	5315-31-341-0315	17	27
09780	2289-A	3120-00-353-1406	16	19
			16	25
			16	48
81834	23-0133-35	5305-01-152-4655	1	3
09780	24-1597	2530-01-340-1636	4	10
09780	24221	3130-01-339-1345	18	7
09780	24222	3130-01-339-8965	20	3
09780	24223-A-1		13	22
09780	24224	3020-01-340-0359	18	19
09780	24225	4010-01-341-6475	18	17
09780	24226-B	9905-01-343-2090	12	8
09780	24227-B	9905-01-343-3843	12	6
09780	24228-A	9905-01-349-4459	12	1
09780	24233-23		2	2
09780	24238-06		2	4
09780	24248		4	6
09780	24250-A	9905-01-343-2085	12	5
09780	24253	3110-00-100-3541	4	2
09780	24255	5330-01-345-2316	4	1
09790	24256	2530-01-366-7047	4	9
09780	24258	5310-01-346-0227	4	11
09780	24260	5310-01-341-6449	3	9
09780	24261	5315-01-339-8803	3	10
09780	24263-A-11	5306-01-346-2893	6	21
09780	24265-B		10	1
09780	24265-B5		10	2
09780	24272-B	5340-01-341-9668	1	11
09780	24273	6240-01-346-8214	1	6
09780	24280-A1	5340-01-342-0531	16	31
09780	24281-A	5310-31-340-8468	16	37
09780	24285	4730-01-339-2153	16	52
09780	24286	4730-01-339-2157	16	50
09783	24296	6145-01-346-3447	BULK	1
09780	24298-A	9905-01-359-3346	12	9
09780	24299-B		11	3
09780	24330-C		11	7
60038	25520	3110-0C-100-0544	4	4
09780	30010-A	5340-01-346-3893	15	16
09780	3314-BF1	5310-01-342-0195	9	40
09780	3314-BF2	5310-01-342-0196	9	39
19328	492005	5940-00-926-0085	2	6

**NATIONAL STOCK NUMBER AND PART NUMBER INDEX
PART NUMBER INDEX**

CAGEC	PART NUMBER	STOCK NUMBER	FIG.	ITEM
81334	50942	6220-01-068-8504	1	2
81834	50952	6220-01-071-1495	1	2
09780	5100-125	5365-00-281-6623	16	44
09780	5202-A	2520-01-339-6814	16	20
09780	5353		17	33
09780	5354-8	2520-01-339-8599	17	35
09780	5379-C-DW	5340-01-340-0381	13	5
09780	5381-C	3020-01-339-1668	18	10
097g0	5332-DW		9	14
09780	57-632		4	3
09780	5889	5365-01-346-2930	9	37
73808	6-00X9	2610-00-089-5997	5	3
09780	60388	5330-00-498-4588	16	35
81834	61-2037-03	5330-01-154-5214	1	5
72741	610-176	5306-01-201-3336	4	5
09780	6834		20	9
09780	6835		20	11
12361	7-376-001472	7690-01-171-9522	12	11
31245	7135-01	3110-00-100-0515	4	7
09780	7155-A	5315-31-346-3463	10	9
09780	7293-A	2540-01-339-8671	9	13
09780	7386-A	3120-01-339-1509	16	16
			16	42
09730	7458-C	5330-00-760-7404	16	5
09780	7611-8		9	25
09780	8183-A	5360-01-341-8665	13	4
09780	3259-B		17	19
36024	8446321	2640-00-535-7509	20	10
09780	8789-3	3030-01-339-0409	15	22
09780	8790-C		9	10
09730	8355-A	3010-01-340-0447	13	6
81834	91302	6220-01-095-2616	1	4
09780	9334-A	5340-01-340-7165	7	1
09780	9617		20	5

CROSS REFERENCE INDEXES

FIG.	ITEM	FIGURE AND ITEM NUMBER INDEX STOCK NUMBER	CAGEC	PART NUMBER
BULK	1	6145-01-346-3447	09730	24296
1	1	6220-01-340-7530	C9730	SA-24220-8-2
1	1	6220-01-341-3257	09790	SA-24220-B-3
1	2	6220-01-068-8504	81634	50942
1	2	6220-01-071-1495	81834	50952
1	3	5305-01-152-4655	81634	23-0133-35
1	4	6220-01-095-2616	81834	91302
1	5	5330-01-154-5214	81834	61-2037-03
1	6	6240-01-346-8214	09780	24273
1	7	5310-00-889-2528	96906	MS45934-68
1	8	5310-30-761-6832	96906	MS51967-2
1	9	5975-31-148-4589	81834	10-7056-01
1	10	6240-00-155-7784	13988	L32257
1	11	5340-01-341-9668	09780	24272-3
2	1	6150-31-343-1250	09780	SA-24220-B-1
2	2		09780	24233-23
2	3	5935-00-059-2841	96996	MS75023-1
2	4		09780	24238-06
2	5	5940-00-143-4777	96906	MS25036-157
2	6	5940-00-926-0085	19328	492005
3	1	5340-01-346-3654	09730	20300-A
3	2	5305-00-071-2070	80204	B18213H050C175N
3	3		09780	SA-20298-D
3	4	5305-00-724-7222	80204	818218H063C200N
3	5	5310-00-820-6653	96906	MS35333-50
3	6	5310-00-763-8920	96906	MS51967-20
3	7	2530-00-484-0647	09780	SA-20301-C
3	8	2530-00-484-0648	07780	SA-20306-C
3	9	5310-01-341-6449	09730	24260
3	10	5315-01-339-8803	09780	24261
3	11	5305-00-724-7224	80204	B18213H063C250N
3	12	5310-00-823-8803	96906	MS27183-21
3	13	5310-00-584-5272	96506	MS35338-48
3	14	5310-00-768-0318	96906	MS51967-14
4	1	5330-01-345-2316	09780	24255
4	2	3110-00-100-3541	09780	24253
4	3		09780	57-632
4	4	3110-00-100-0544	60036	25520
4	5	5306-01-201-3336	72741	610-176
4	6		09780	24245
4	7	3110-00-100-0515	31245	7135-01
4	8	3110-00-142-4355	13F03	14125A
4	9	2530-01-366-7347	09780	24256
4	10	2530-01-340-1636	09780	24-1597
4	11	5310-01-346-0227	09780	24258
5	1	2610-00-540-4719	81349	MIL-T-12459/CLMS /SB/9.00-16/D/MS
5	2	2610-00-050-9870	96996	MS35389-34
5	3	2610-00-039-5997	73808	6-00X9
6	1		09730	SA-19672-D
6	2		09780	SA-19663-D

CROSS REFERENCE INDEXES

FIG.	ITEM	FIGURE AND ITEM NUMBER INDEX STOCK NUMBER	CAGEC	PART NUMBER
6	3	5305-00-071-2067	80204	B1821BH050C125N
6	4		09780	19672-DA
6	5	5315-01-156-5229	96906	MS17990-827
6	6		09780	19672-DE
6	7		09780	19672-DC
6	8	5305-00-068-0510	80204	B18216H038C100N
6	9	5310-00-809-5997	96906	MS27183-17
6	10	5310-00-768-0318	96906	MS51967-14
6	11	5310-00-584-5272	96906	MS35333-48
6	12	5340-01-346-3639	09780	19672-D14
6	13	5360-01-346-2899	09780	19672-D15
6	14	5310-00-823-8803	96906	MS27183-21
6	15	5315-00-839-5322	96906	MS24665-353
6	16		09780	19672-08
6	17	5310-00-732-0558	96906	MS51967-8
6	18	5310-00-637-9541	96906	MS35338-46
6	19		09780	19672-D0
6	20	5305-01-242-1782	96906	M551869-5
6	21	5306-01-346-2393	07770	24263-A-11
6	22	5310-00-584-7388	96906	MS35338-51
6	23	5305-00-725-0163	96936	MS51963-140
6	24		09730	SA-10074-5
7	1	5340-01-340-7165	09730	9334-A
7	2	2510-01-340-1456	09730	SA-9343-A
7	3	5310-00-820-6653	96906	MS35338-50
7	4	5310-00-763-8920	96936	MS51967-20
7	5	2540-01-339-2327	09730	SA-20313-8
7	6	5305-00-724-7224	80204	B18213H063C250N
7	7		09780	SA-9338-A
7	8	5305-30-071-2069	80204	B1821BH050C150N
7	9	5310-00-584-5272	96906	MS35338-48
7	10	5310-00-768-0313	96906	MS51967-14
7	11	4010-01-339-4216	09780	SA-20434-A
7	12		09730	SA-20434-A2
7	13	5315-00-842-3044	96906	MS24665-283
7	14		09780	SA-20434-A3
8	1	5310-00-167-0826	83544	AN960-1216
8	2	5310-00-584-5272	96906	MS35338-48
8	3	5310-00-768-0313	96906	MS51967-14
8	4	3330-01-355-6012	09780	SA-20232-D
8	5	5305-00-071-2081	80204	B1821BH050C450N
9	1		09780	SA-8326-D
9	2	5310-00-768-0318	96906	MS51967-14
9	3	5310-00-584-5272	96906	MS35338-48
9	4	5306-00-021-8150	96906	MS35754-34
9	5		09730	SA-5150-3
9	6	3830-01-339-8583	09790	SA-22329-B
9	7	5360-01-346-2900	09790	2202-A
9	8	5315-00-187-9567	96906	MS24665-500
9	9		09780	2176-A
9	10			09780 8790-C

CROSS REFERENCE INDEXES

FIG.	ITEM	FIGURE AND ITEM NUMBER INDEX STOCK NUMBER	CAGEC	PART NUMBER
9	11	5305-00-068-0510	80204	B1821SH038C100N
9	12	5310-00-637-9541	96906	MS35338-46
9	13	2540-01-339-8671	09780	7293-A
9	14		C9780	5382-CW
9	15	5310-00-768-0313	96906	MS51967-14
9	16	5310-00-584-5272	96906	MS35338-48
9	17	5365-01-342-8610	09780	2193-A
9	18	5365-01-346-2944	09780	2192-A
9	19	5305-00-071-2073	80204	B1821BH050C250N
9	20	5306-01-339-4149	0978C	2196-B
9	21	5315-00-187-9567	96906	MS24665-500
9	22	5310-00-732-0558	96906	MS51967-8
9	23	5310-00-637-9541	969C6	MS35333-46
9	24	3013-01-175-9722	06495	101-2-101
9	25		09730	7611-B
9	25	5305-00-638-8920	80204	B1821BH038C225N
9	27	5310-01-305-4341	96906	MS51943-49
9	28	4730-00-050-4207	96906	MS15001-4
9	29	5310-00-409-3333	96906	MS51943-45
9	30	5305-00-071-2067	80204	B1821BH050C125N
9	31		09730	10349-B
9	32		09780	2130-A
9	33	5365-01-339-8901	09780	2127
9	34	5306-01-346-2892	09780	2195
9	35	5306-01-339-3919	09780	2194-A
9	36		09780	2131-A
9	37	5365-01-346-2930	09780	5889
9	33	5310-00-809-3541	96906	MS27183-27
9	39	5310-01-342-0196	09790	3314-8F2
9	40	5310-01-342-0195	09730	3314-3F1
10	1		09790	24265-B
10	2		09780	24265-85
10	3	5305-00-165-8074	96906	MS51095-420
10	4		0973C	SA-20403-A
10	5		09780	SA-20402-A
10	6	5310-00-584-5272	96906	MS35338-48
10	7	5310-00-768-0313	96906	MS51967-14
10	3	5315-01-081-9991	83044	AN415-6
10	9	5315-01-346-3463	09730	7155-A
10	10	5310-00-880-7744	96906	MS51967-5
11	1		09780	20491-A
11	2	5305-00-165-8036	21450	193031
11	3		09780	24299-3
11	4		09780	20492-A
11	5	5310-00-637-9541	96906	MS35338-46
11	6	5310-01-088-2490	96906	MS35425-74
11	7		09780	24300-C
11	8	9905-00-205-2795	96906	MS35387-1
11	9	5305-00-068-0500	96906	MS90725-3
11	13	5310-00-582-5965	96906	MS35338-44
11	11	5310-00-761-6882	96906	MS51967-2

CROSS REFERENCE INDEXES

FIG.	ITEM	FIGURE AND ITEM NUMBER INDEX STOCK NUMBER	CAGEC	PART NUMBER
11	12	5310-00-732-0558	96906	MS51967-8
11	13	5310-00-637-9541	96936	MS35338-46
11	14	5305-00-269-3211	96906	MS907Z5-60
11	15		09780	SA-20356-B
11	16	5310-00-768-0318	96906	MS51967-14
11	17	5310-00-584-5272	96906	MS35338-48
11	18	5310-30-809-5997	96906	MS27183-17
11	19	5305-00-543-2366	80204	B1821BH038C250N
11	20	5310-00-080-60C4	96906	MS27183-14
12	1	9905-01-349-4459	09780	24223-A
12	2	5305-00-253-5618	969V6	MS21313-27
12	3	9905-01-343-4407	09780	20517-A
12	4	9905-01-342-9013	09780	20518-A
12	5	9905-01-343-2085	09733	24250-A
12	6	9905-01-343-3343	09780	24227-B
12	7	9905-01-343-2076	09730	20371-A
12	8	9905-01-343-2090	09730	24226-B
12	9	9905-01-359-3346	09730	24298-A
12	10	7690-01-143-6993	58752	S32-23
12	11	7590-01-171-9522	12361	7-376-001472
13	1	3040-01-340-1789	09780	SA-8854-B
13	2	5310-00-061-4651	96906	MS51943-43
13	3	5310-00-823-8303	96906	MS27183-21
13	4	5360-01-341-8665	09780	8183-A
13	5	5340-01-340-0381	09780	5379-C-0W
13	6	3010-01-340-0447	09780	8855-A
13	7	3040-01-341-1470	09780	2227-A
13	8	5305-00-724-5882	96906	MS51963-105
13	9	5310-00-582-5965	96906	MS35338-44
13	10	5310-00-761-6182	96936	MS51967-2
13	11	3040-01-339-7960	09780	SA-10136-C
13	12	5310-00-935-9021	96906	MS51943-35
13	13	5305-00-782-9489	30204	B1821BH038C200N
13	14	5305-00-071-2510	80204	B1821BH025C175N
14	1	5310-00-768-0318	96906	MS51967-14
14	2	5310-00-584-5272	96906	MS35338-48
14	3	5315-00-298-1499	96906	MS246o5-360
14	4	5310-00-998-0608	96906	MS35692-61
14	5		09780	SA-5137-B
14	6		09780	2124-3
14	7	5305-00-071-2069	80204	B1821BH050C150N
14	8		09780	2126-A
14	9	5310-00-488-3889	95930	MS51943-39
14	10	5310-00-809-5997	96906	MS27183-17
14	11	5305-00-071-2067	83234	B1821BH050C125N
14	12		09780	SA-9783-B
14	13		04780	SA-2146-C
15	1	4730-00-050-4208	96906	MS15003-1
15	2	5310-00-768-0318	96906	MS51967-14
15	3	5310-00-584-5272	96906	MS35338-48
15	4	5310-00-809-5997	96936	MS27133-17

CROSS REFERENCE INDEXES

FIG.	ITEM	FIGURE AND ITEM NUMBER INDEX STOCK NUMBER	CAGEC	PART NUMBER
15	5	5305-00-054-9271	96936	MS51955-36
15	6		09750	SA-6448-D
15	7	3040-01-340-8779	09780	2177-A
15	8	3040-01-291-9579	09730	SA-8450-3
15	9	3040-01-340-4771	09730	SA-2178-A
15	10	3120-01-341-8993	09780	SA-5139-B
15	11	3130-01-348-3793	09730	2122-A
15	12	5305-00-071-2069	83234	B1821BH050C150N
15	13	5305-00-071-2077	80204	B1821BH05CC350N
15	14		09730	2123-A
15	15		09780	SA-8438-3
15	16	5340-01-346-3893	09780	30010-A
15	17	5315-01-019-9306	96906	MS171590
15	18		09780	20444-B
15	19	5310-00-732-0553	96906	MS51967-3
15	20	5310-00-637-9541	96906	MS35338-46
15	21	5310-00-080-6004	95906	MS27183-14
15	22	3030-31-339-0409	09739	3789-3
15	23	3030-01-339-0409	09780	20510-A1
15	24	5305-30-725-2317	80204	B1821BH038C150N
15	25	5305-00-068-0511	80204	B1821BH038C125N
15	26		09780	2260-A
15	27	5305-00-821-3369	80204	B1821BH038C175N
15	23	5305-00-071-2071	80204	B1321B4H050C200N
16	1		09780	SA-5002-D
16	2	5310-00-011-5093	96906	MS35333-65
16	3	5305-00-543-4372	30234	B1821BH03C0075N
16	4		09780	221-C
16	5	5330-00-760-7404	09780	7453-C
16	5	5340-01-339-3313	09780	SA-5?C3-3
16	7	5310-00-407-9566	90906	MS35338-45
16	3	5310-00-982-4949	96906	MS27040-11
16	9	2520-01-339-8658	09780	SA-5140-3
16	10	3040-01-339-1578	09780	2225-A
16	11	5315-00-187-9412	96906	MS24665-653
16	12	5306-00-226-4331	80204	B1812BH031C150N
16	13	5305-00-071-2067	30234	B1821BH050C125N
16	14	5313-00-584-5272	95936	MS35333-48
16	15	3120-01-342-3138	09780	SA-6946-C
16	16	3123-01-339-1509	99780	7386-A
16	17	5330-31-339-1448	09780	19134-A
16	18	3010-01-339-1647	09780	SA-5011-B
16	19	3120-00-353-1406	09780	2289-A
16	23	2520-01-339-6314	09733	5232-A
16	21	5305-00-914-7643	96906	MS90727-185
16	22	5310-00-584-7883	95906	MS35338-51
16	23	3040-01-339-1577	09730	2164-A
16	24	3020-01-339-1628	09780	SA-5145-B
16	25	3120-00-353-1406	09780	2289-A
16	26		09780	2173-A
16	27	3123-00-410-6433	71366	TW125

**NATIONAL STOCK NUMBER AND PART NUMBER INDEX
PART NUMBER INDEX**

CAGEC	PART NUMBER	STOCK NUMBER	FIG.	ITEM
16	23	5310-00-732-0559	96906	MS51967-3
16	29	5310-00-637-9541	96906	MS35338-46
16	30		09780	2247-A
16	31	5340-01-342-0531	09780	24280-A1
16	32	9505-00-555-8648	96906	MS20995C47
16	33	3040-01-339-8573	09780	SA-5143-BA
16	34	5315-00-616-5506	96906	MS35756-30
16	35	5330-00-498-4588	09780	60388
16	36	3040-01-339-1579	c9780	2162-8A
156	37	5310-01-340-846	09Q780	24281-A
16	38	4730-01-338-2227	96906	MS14314-6Z
16	39	5305-00-068-0511	80204	B1821BH38C125N
16	40	4730-01-135-8310	96906	MS49006-8
16	41		09780	SA-5001-C
16	42	3120-01-339-1509	09780	7386-A
16	43	3020-01-348-3865	09780	2172-B
16	44	5365-00-281-6623	09780	5100-125
16	45	3020-01-339-1629	09780	2171-C
16	46	3020-01-339-1627	09780	SA-5010-C
16	47	5310-01-346-0394	09780	SA-5010-C4
16	48	3120-00-353-1406	09780	2239-A
16	49	4730-00-188-3515	96906	MS20913-4
16	50	4730-01-339-2157	09780	24286
16	51	4730-00-253-4414	96906	MS39230-4
16	52	4730-01-339-2158	09730	24285
16	53	5305-00-071-2069	80204	B1821BH050C150N
16	54	5310-00-761-3706	96906	MS51967-15
16	55	5310-00-584-5272	96906	MS35338-48
16	56		09780	2212-A1
16	57		09780	2266-81
16	58		09780	2212-A2
16	58		09730	2213-A2
16	59		09780	2266-32
16	60		09780	2213-A1
16	61	5310-00-809-5997	96936	MS27183-17
17	1		09780	SA-8445-B
17	2	5315-01-341-9643	09780	2169-A
17	3	3040-01-345-3951	09780	2248-A
17	4	5305-00-724-5882	96906	MS51963-105
17	5	5310-00-935-9021	96906	MS51943-35
17	6	4310-01-339-8714	09780	SA-8446-B
17	7	3120-01-346-1504	09780	SA-22427-B
17	8	3120-01-340-9932	09780	2157
17	9	4730-00-172-0034	96906	MS15003-6
17	10	5310-00-584-5272	96906	MS35338-48
17	11	5310-00-768-0318	96906	MS51967-14
17	12	5335-00-269-3217	96996	MS90725-67
17	13	5315-01-345-6743	09780	2168-8
17	14	5305-00-071-2069	80204	B1821BH050C150N
17	15	5306-00-021-8150	96906	MS35754-34
17	16	5343-01-346-4294	09783	2239-A

CROSS REFERENCE INDEXES

FIG.	ITEM	FIGURE AND ITEM NUMBER INDEX STOCK NUMBER	CAGEC	PART NUMBER
17	17	5305-00-071-2071	30204	B1821BH050C200N
17	18	4730-00-050-4208	95906	MS15033-1
17	19		09780	8259-B
17	20	3130-01-339-1558	09780	SA-22493-B
17	21	3120-01-340-9932	09730	2157
17	22	5305-00-071-2070	38204	B1821BH050C175N
17	23	5340-01-342-0362	09780	2267-9
17	24	5340-01-342-4992	09780	2229-B
17	25	5310-00-809-5997	95906	MS27183-17
17	26	3040-01-341-0183	09780	2268-8
17	27	5315-01-341-0815	09730	2237
17	29	5315-00-234-1664	96936	MS24665-495
17	29	2520-01-339-8657	09780	SA-8032-A
17	30	5310-00-488-3889	96936	MS51943-39
17	31	5315-00-616-5506	96906	MS35755-30
17	32	3120-00-222-1545	09730	SA-5352-3
17	33		09730	5353
17	34	3120-00-079-8142	71041	32326-16
17	35	2520-01-339-6599	39780	5354-5
17	36	3040-01-339-8569	09780	SA-5421-3
17	37	3020-01-340-03630	09780	SA-8445-C-22
17	39	3020-01-340-0469	09780	2160-A
17	39	4010-01-341-6474	09780	SA-8445-C-23
17	40	5310-01-064-3422	96906	MS35690-504
17	41	3020-01-361-5158	09780	SA-5147-C
17	42	5310-00-809-5997	96936	MS27183-17
17	43	5310-00-584-5272	96906	MS35338-48
17	44	5310-00-768-0313	96906	MS51967-14
17	45	5305-00-071-2069	80204	B1821BH050C150N
17	46	5305-00-846-5703	80234	B1821BH033C300N
17	47	3020-01-340-1642	09780	2161-A
17	48	3123-00-222-1543	09780	SA-22492-B
17	49	3120-31-340-9932	09780	2157
17	50	5340-01-343-1794	09780	2230-8
17	51	5315-01-340-0347	09780	2167-A
18	1	5310-00-768-0318	96906	MS51907-14
13	2	5310-00-584-5272	96906	MS35338-48
13	3	4730-00-172-0034	96906	MS15003-6
18	4	5306-00-021-8150	96906	MS35754-34
18	5	5315-00-616-5506	96906	MS35756-30
19	6	3395-01-340-0513	09780	SA-8460-DW
13	7	3130-01-339-1345	09780	24221
19	8	5305-00-846-5703	83204	B1321BH038C300N
18	9	4730-00-050-4208	96906	MS15003-1
18	10	3020-01-339-1608	09780	5381-C
18	11	5305-30-071-2369	80204	B1821BH050C150N
18	12	5310-00-809-5997	96906	MS27163-17
18	13	5310-00-584-5272	96906	MS35338-48
18	14	5310-00-768-0318	96906	MS51967-14
13	15	3020-01-361-5159	09780	SA-5146-C
18	16	3020-01-339-8679	09730	SA-2159-A

**NATIONAL STOCK NUMBER AND PART NUMBER INDEX
PART NUMBER INDEX**

CAGEC	PART NUMBER	STOCK NUMBER	FIG.	ITEM
18	17	4010-01-341-6475	09780	24225
18	18	5310-00-732-0553	96906	MS51967-8
18	19	3020-01-340-0359	09790	24224
18	20	5305-00-724-5882	96906	MS51963-105
18	21	5305-00-723-9381	9690C6	MS51963-69
18	22		09780	24223-A-1
19	1	5310-00-763-8920	96906	MS51967-20
19	2	5310-00-820-6653	96906	MS35333-50
19	3	5340-01-346-3655	09780	10329-A
19	4	5305-00-724-7222	80204	B1821BH063C200N
19	5	5340-01-355-6874	09730	10330-A
19	6	5340-01-355-5261	09730	SA-10302-81
19	7	3040-01-355-5937	09780	SA-15451-A
19	8	3910-01-355-7807	09780	SA-10303-B
19	9	5305-00-724-5882	96906	MS51963-105
19	10	5340-01-355-5262	09780	SA-13302-B2
20	1	3040-00-434-0740	09730	2263-A
20	2		09780	2235
20	3	3130-01-339-8965	09780	24222
20	4	4730-00-050-4208	96906	MS15003-1
20	5		09780	9617
20	6	2530-01-346-0106	09780	SA-8719-C
20	7	5310-00-234-7815	96906	MS35690-724
20	8	5310-00-209-0965	96906	MS35338-47
20	9		09780	6834
20	10	2640-00-535-7509	36024	8446321
20	11		09780	6835
20	12		09780	SA-6804-C
20	13	5305-00-709-8539	96906	MS90727-89
20	14	5305-30-071-2073	80204	B1821BH050C250N
20	15	5310-00-809-5997	96906	MS27183-17
20	16	5310-00-584-5272	95906	MS35338-48
20	17	5310-00-768-0318	96906	MS51967-14
20	18		09780	2156

**APPENDIX G
ILLUSTRATED LIST OF MANUFACTURED ITEMS**

Section I. INTRODUCTION

G-1. SCOPE.

This appendix includes complete instructions for making items authorized to be manufactured or fabricated at unit maintenance.

A part number index in alphanumeric order is provided for cross-referencing the part number of the item to be manufactured to the figure that covers fabrication criteria.

G-2. MANUFACTURED ITEMS PART NUMBER INDEX.

PART NUMBER	FIGURE NUMBER
20492-A	G-1
SA-24220-B-1	G-2

Section II. MANUFACTURED ITEMS ILLUSTRATIONS

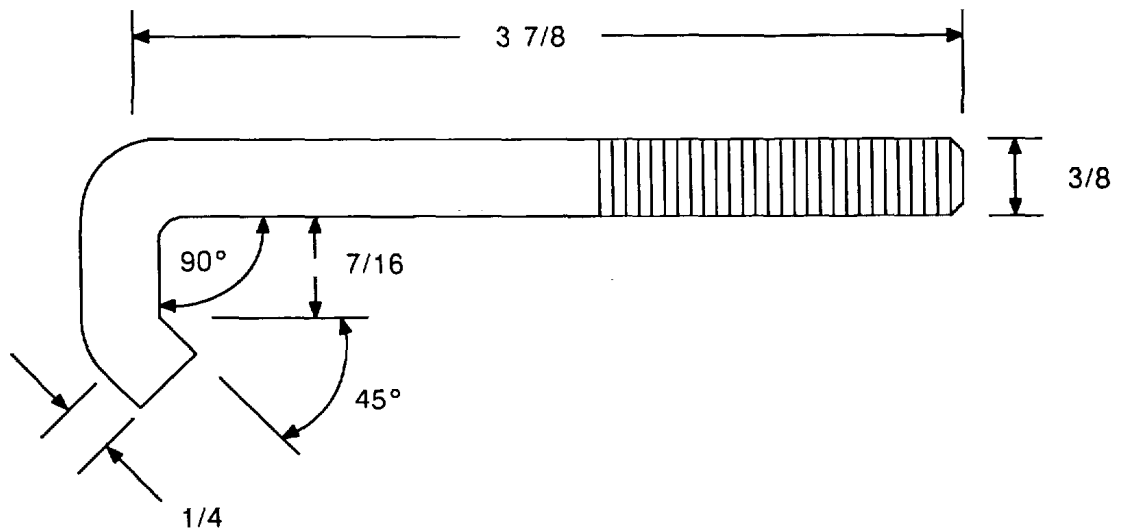

NOTES:

1. Make from MS90725-78
2. Cut off head then bend as shown
3. Four required

Figure G-1. J-BOLT

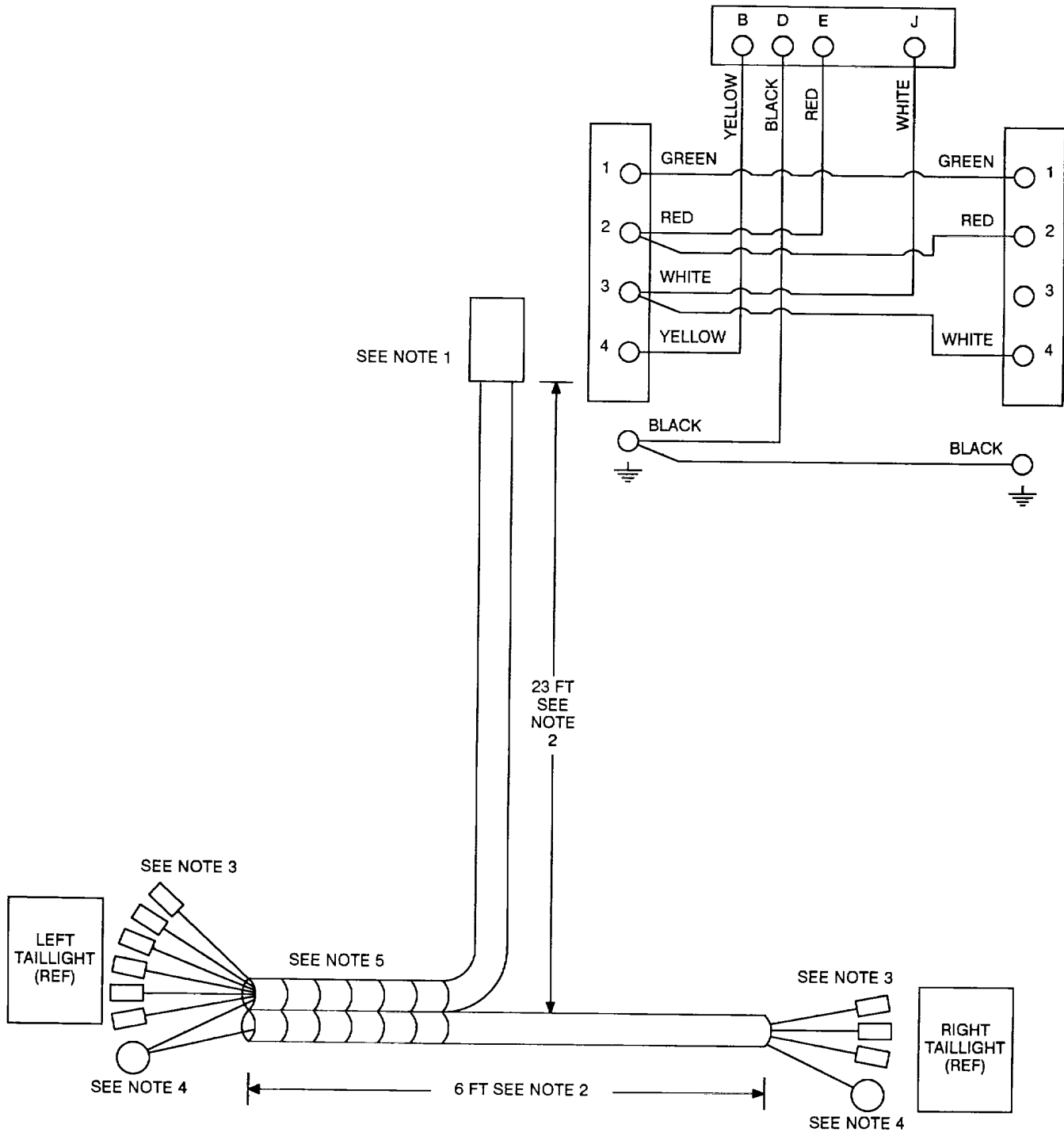

NOTES:

- 1. Connector plug, MS75020-1
- 2. Manufacture from P/N 24296
- 3. Quick-disconnect terminal, P/N 492005
- 4. Lug terminal, MS25036-157
- 5. Insulation tape, P/N HH1510 (Item 14, Appendix E)

Figure G-2. MAIN BODY HARNESS

**APPENDIX H
TORQUE SPECIFICATIONS**

H-1. SCOPE.

This appendix lists standard torque values and provides general information for applying torque. Special torque values are indicated in the maintenance procedures for applicable components.

The torque values listed are for Grade 5 and Grade 8 steel screws, sizes 0.250 through 0.750 in. diameter, Class 2A thread.

H-2. GENERAL.

Always use the torque values listed below when the maintenance procedure does not give a specific torque value.

Unless otherwise specified, standard torque tolerance shall be plus or minus 10 percent.

Torque values are based on clean, dry threads. Reduce torque by 10 percent when engine oil is used as a lubricant.

Reduce torque by 20 percent if new plated capscrews are used.

Capscrews threaded into aluminum may require reductions in torque of 30 percent or more. Capscrews threaded into aluminum must attain two diameters of thread engagement.

Table H-1. TORQUE REQUIREMENTS

CAUTION

If replacement capscrews are of a higher grade than originally supplied, use torque specifications for the original. This will prevent equipment damage due to overtorquing.

Capscrew Body Size		Torque
Inches	Thread	lb-ft
1/4	20	8
	28	10
5-16	18	17
	24	19
3/8	16	31
	24	35
7-16	14	49
	20	55
1/2	13	75
	20	85
9/16	12	110
	18	120
5/8	11	150
	18	170
3/4	10	270
	16	295

H-1/H-2 (blank)

ALPHABETICAL INDEX

Subject, Page

A

Additional Authorization List:
 Explanation of Columns, D-1
 General, D-1
 List, D-1
 Scope, D-1
 Adjusting Shaft, Gate, Replacement, 4-52
 Adjustment Screw, Gate, Replacement, 4-51
 Administrative Storage, 4-71
 Aggregate, Spreading, 2-7
 Agitator:
 Drive Chain Replacement, 4-62
 Principles of Operation, 1-6
 Repair, 5-14
 Arm, Clutch Shift, Repair, 4-48
 Axle, Transport Truck, Replacement, 4-34

B

Balance Roller Repair, 4-64
 Balancing Handle Replacement, 4-55
 Basic Issue Items:
 Explanation of Columns, C-1
 General, C-1
 List, C-2
 Scope, C-1
 Bearings, Gate, Replacement, 4-52
 Belting Replacement, 4-53
 Brackets, Gate, Replacement, 4-56

C

Chain and Sprocket, Feed Roll Drive, Replacement, 4-63
 Chain, Agitator Drive, Replacement, 4-62
 Characteristics, Capabilities, and Features, Equipment, 1-2
 Chart, Maintenance Allocation:
 Explanation of Columns:
 Section II, B-2
 Section III, B-2
 Section IV, B-2
 General, B-1
 Maintenance Functions, B-1
 Clutch Shift Arm, Repair, 4-48
 Cold, Extreme, Operation in, 2-12

Subject, Page

Columns, Explanation of:
 Components of End Item and Basic Issue Items Lists, C-1
 Expendable/Durable Supplies and Materials List, E-1
 Maintenance Allocation Chart:
 Section II, B-2
 Section III, B-2
 Section IV, B-2
 PMCS, 2-4, 4-2
 Repair Parts and Special Tools List:
 Section IV, F-4
 Sections II and III, F-1
 Troubleshooting, 3-6, 4-4
 Common Tools and Equipment, 4-2
 Components of End Item and Basic Issue Items Lists:
 BII List, C-2
 Components of End Item List (Not Applicable), C-1
 Explanation of Columns, C-1
 General, C-1
 Scope, C-1
 Controls and Indicators, 2-2
 Coupling and Uncoupling Spreader, 4-29
 Coupler Hitch and Crank Repair, 5-1
 Coupler Hitch and Truck Hitch, Principles of Operation, 1-6

D

Data, Equipment, 1-5
 Decals and Instruction Plates, Operating Instructions on, 2-11
 Definitions, Leakage, 2-4, 4-2
 Description of Major Components, Location and, 1-2
 Destruction of Army Materiel to Prevent Enemy Use, 1-2
 Drive, Traction, Principles of Operation, 1-6
 Dusty or Sandy Areas, Operation in, 2-12

E

EIRs, 1-2
 Equipment:
 Characteristics, Capabilities, and Features, 1-2
 Common Tools and, 4-2
 Data, 1-5
 Improvement Recommendations (EIRs), Reporting, 1-2
 Support, 4-2

Subject, Page

Expendable/Durable Supplies and Materials List:

- Explanation of Columns, E-1
- List, E-2
- Scope, E-1

Explanation of Columns:

- Components of End Item and Basic Issue Items Lists, C-1
- Expendable/Durable Supplies and Materials List, E-1
- Maintenance Allocation Chart:
 - Section II, B-2
 - Section III, B-2
 - Section IV, B-2

PMCS, 2-4, 4-2

Repair Parts and Special Tools List:

- Section IV, F-4
- Sections II and III, F-1
- Troubleshooting, 3-6, 4-4

F

Features, Characteristics, and Capabilities, Equipment, 1-2

Feed Roll:

- Control Lever Replacement, 4-47
- Drive Chain and Sprocket Replacement, 4-63
- Principles of Operation, 1-6
- Replacement, 5-23

Fording, 2-12

Forms, Records, and Reports, Maintenance, 1-1

Functions, Maintenance, B-1

G

Gate:

- Adjusting Lever Replacement, 4-50
- Adjusting Shaft Replacement, 4-52
- Adjustment Screw Replacement, 4-51
- Bearings Replacement, 4-52
- Rack Replacement, 4-50
- Replacement, 4-56

Gearbox:

- Principles of Operation, 1-6
- Repair, 5-7
- Replacement, 4-57

General PMCS Information, 2-3

H

Handle Balancing, Replacement, 4-55

Harness, Wiring, Repair, 4-32

High Humidity, Operation in, 2-12

Hitch, Coupler, Principles of Operation, 1-6

Subject, Page

Hitch, Truck:

- Installing and Removing, 4-20
- Replacement, 4-43

How to Locate Repair Parts, F-5

Hub, Wheel, Transport Truck, Repair, 4-36

I

Illustrated List of Manufactured Items:

Manufactured Items Illustrations:

- J-bolt, G-1
- Main Body Harness, G-2
- Part Number Index, G-1

Scope, G-1

Index, Symptom, Troubleshooting, 3-6, 4-4

Indicators, Controls and, 2-2

Information, General PMCS, 2-3

Instruction Plates, Operating Instructions on Decals and, 2-11

Instructions, Lubrication:

- Specific, 3-1
- Under Unusual Conditions, 3-2

L

Leakage Definitions, 2-4, 4-2

Leveling Leg Repair, 4-44

Lever:

- Feed Roll Control, Replacement, 4-47
- Gate Adjusting, Replacement, 4-50

List:

- Additional Authorization, D-1
- Basic Issue Items, C-2
- Components of End Item (Not Applicable), C-1
- Expendable/Durable Supplies and Materials, E-2
- Manufactured Items:
 - J-bolt, G-1
 - Main Body Harness, G-2
- Repair Parts and Special Tools, F-1

Location and Content of Stencil Markings, 1-5

Location and Description of Major Components, 1-2

Lubrication:

- Specific Instructions, 3-1
- Under Unusual Conditions, 3-2

M

Maintenance Allocation Chart:

Explanation of Columns:

- Section II, B-2
- Section III, B-2
- Section IV, B-2

General, B-1

Maintenance Functions, B-1

Subject, Page

Maintenance Forms, Records, and Reports, 1-1
 Major Components, Location and Description of, 1-2
 Movement, Preparation for:
 Introduction, 2-9
 Long Move, 2-9
 Short Move, 2-9
 Mud, Operation in, 2-12

O

Operating Instructions on Decals and Instruction
 Plates, 2-11
 Operation in:
 Cold, 2-12
 Heat, 2-12
 High Humidity, 2-12
 Mud, 2-12
 Saltwater Areas, 2-12
 Sand or Dusty Areas, 2-12
 Snow, 2-12
 Operator's Platform:
 Installing and Removing, 4-24
 Repair, 4-38

P

Parts, Repair, 4-2
 Plate, Data, Replacement, 4-46
 Platform, Operator's:
 Installing and Removing, 4-24
 Repair, 4-38
 PMCS:
 Information, General, 2-3
 Procedures, 2-4, 4-2
 Preparation for Movement:
 Introduction, 2-9
 Long Move, 2-9
 Short Move, 2-9
 Preparation for Operation:
 Coupling and Uncoupling Spreader, 4-29
 Installing and Removing Operator's Platform, 4-24
 Installing and Removing Truck Hitch, 4-20
 Removing and Installing Taillights, 4-9
 Removing and Installing Transport Truck and
 Tongue,
 4-11
 Preparation:
 For Shipment, 4-73
 For Storage or Shipment, 1-2
 Procedures, PMCS, 2-4, 4-2

R

Rack, Gate, Replacement, 4-50
 Records, Reports, and Forms, Maintenance, 1-1

Subject, Page

Reflector Replacement, 4-45
 Repair Parts and Special Tools List:
 Abbreviations, F-5
 Explanation of Columns:
 Section IV, F-4
 Sections II and III, F-1
 General, F-1
 How to Locate Repair Parts, F-5
 Scope, F-1
 Special Information, F-4
 Repair:
 Agitator, 5-14
 Balance Roller, 4-64
 Clutch Shift Arm, 4-48
 Coupler Hitch and Crank, 5-1
 Gearbox, 5-7
 Leveling Leg, 4-44
 Operator's Platform, 4-38
 Taillight, 4-31
 Tire, 5-1
 Tires and Tubes, 4-37
 Traction Wheel Assembly, 4-66
 Transport Truck Wheel Hub, 4-36
 Wiring Harness, 4-32
 Replacement:
 Agitator Drive Chain, 4-62
 Balancing Handle, 4-55
 Belting, 4-53
 Data Plate, 4-46
 Feed Roll, 5-23
 Feed Roll Control Lever, 4-47
 Feed Roll Drive Chain and Sprocket, 4-63
 Gate:
 Adjusting Lever, 4-50
 Adjusting Shaft, 4-52
 Adjustment Screw, 4-51
 Bearings, 4-52
 Rack, 4-50
 Replacement, 4-56
 Gearbox, 4-57
 Reflector, 4-45
 Toolbox, 4-46
 Transport Tongue and Mounting Components, 4-41
 Transport Truck:
 Axle, 4-34
 Wheel, 4-35
 Truck Hitch, 4-43
 Reporting Equipment Improvement Recommendations
 (EIRs), 1-2
 Reports, Forms, and Records, Maintenance, 1-1
 Roller, Balance, Repair, 4-64

Subject, Page

S

Saltwater Areas, Operation in, 2-12
 Sandy or Dusty Areas, Operation in, 2-12
 Scope of Manual, 1-1
 Screw, Gate Adjustment, Replacement, 4-51
 Shaft, Gate Adjusting, Replacement, 4-52
 Shift Arm, Clutch, Repair, 4-48
 Shipment, Preparation for, 4-73
 Snow, Operation in, 2-12
 Special Tools, TMDE, and Support Equipment, 4-2
 Specific Lubrication Instructions, 3-1
 Specifications, Torque:
 General, H-1
 Requirements, H-1
 Scope, H-1
 Spreading Aggregate, 2-7
 Stencil Markings, Location and Content, 1-5
 Storage:
 Administrative, 4-71
 Preparation for, 1-2
 Supplies and Materials List, Expendable/Durable:
 Explanation of Columns, E-1
 List, E-2
 Scope, E-1
 Support Equipment, 4-2
 Symptom Index, Troubleshooting, 3-6, 4-4

T

Taillights:
 Removing and Installing, 4-9
 Repair, 4-31

Subject, Page

Tire Repair, 5-1
 Tires and Tubes Repair, 4-37
 TMDE, 4-2
 Tongue, Transport, Replacement, 4-41
 Toolbox Replacement, 4-46
 Tools:
 Common, 4-2
 Special, 4-2
 Torque Specifications:
 General, H-1
 Requirements, H-1
 Scope, H-1
 Traction Drive, Principles of Operation, 1-6
 Traction Wheel Assembly Repair, 4-66
 Transport Tongue and Mounting Components Replacement, 4-41
 Transport Truck:
 Axle Replacement, 4-34
 Removing and Installing, 4-11
 Wheel:
 Hub Repair, 4-36
 Replacement, 4-35
 Tubes and Tires Repair, 4-37

U

Unusual Conditions, Lubrication, 3-2

W

Wheel Assembly, Traction, Repair, 4-66
 Wheel, Transport Truck:
 Hub Repair, 4-36
 Replacement, 4-35
 Wiring Harness Repair, 4-32

By Order of the Secretary of the Army:

GORDON E. SULLIVAN
General, United States Army
Chief of Staff

Official:

MILTON H. HAMILTON
Administrative Assistant to the
Secretary of the Army
04223

Distribution:

To be distributed in accordance with DA Form 12-25-E, Block 5362, requirements for TRS-3825-230-14 & P.

RECOMMENDED CHANGES TO EQUIPMENT TECHNICAL PUBLICATIONS



THEN... JOT DOWN THE DOPE ABOUT IT ON THIS FORM, CAREFULLY TEAR IT OUT, FOLD IT AND DROP IT IN THE MAIL!

SOMETHING WRONG WITH THIS PUBLICATION?

FROM: (PRINT YOUR UNIT'S COMPLETE ADDRESS)

DATE SENT

PUBLICATION NUMBER

PUBLICATION DATE

PUBLICATION TITLE

BE EXACT... PIN-POINT WHERE IT IS

IN THIS SPACE TELL WHAT IS WRONG AND WHAT SHOULD BE DONE ABOUT IT:

PAGE NO.	PARA-GRAPH	FIGURE NO.	TABLE NO.

TEAR ALONG PERFORATED LINE

PRINTED NAME, GRADE OR TITLE, AND TELEPHONE NUMBER

SIGN HERE:

DA FORM 2028-2
1 JUL 79

PREVIOUS EDITIONS ARE OBSOLETE.

P.S.—IF YOUR OUTFIT WANTS TO KNOW ABOUT YOUR RECOMMENDATION MAKE A CARBON COPY OF THIS AND GIVE IT TO YOUR HEADQUARTERS.

THE METRIC SYSTEM AND EQUIVALENTS

LINEAR MEASURE

- 1 Centimeter = 10 Millimeters = 0.01 Meters = 0.3937 Inches
- 1 Meter = 100 Centimeters = 1,000 Millimeters = 39.37 Inches
- 1 Kilometer = 1,000 Meters = 0.621 Miles

SQUARE MEASURE

- 1 Sq Centimeter = 100 Sq Millimeters = 0.155 Sq Inches
- 1 Sq Meter = 10,000 Sq Centimeters = 10.76 Sq Feet
- 1 Sq Kilometer = 1,000,000 Sq Meters = 0.386 Sq Miles

CUBIC MEASURE

- 1 Cu Centimeter = 1,000 Cu Millimeters = 0.06 Cu Inches
- 1 Cu Meter = 1,000,000 Cu Centimeters = 35.31 Cu Feet

LIQUID MEASURE

- 1 Milliliter = 0.001 Liters = 0.0338 Fluid Ounces
- 1 Liter = 1,000 Milliliters = 33.82 Fluid Ounces

TEMPERATURE

- $5/9 (^{\circ}\text{F} - 32) = ^{\circ}\text{C}$
- 212 $^{\circ}$ Fahrenheit is equivalent to 100 $^{\circ}$ Celsius
- 90 $^{\circ}$ Fahrenheit is equivalent to 32.2 $^{\circ}$ Celsius
- 32 $^{\circ}$ Fahrenheit is equivalent to 0 $^{\circ}$ Celsius
- $9/5 \text{ C}^{\circ} + 32 = \text{F}^{\circ}$

WEIGHTS

- 1 Gram = 0.001 Kilograms = 1,000 Milligrams = 0.035 Ounces
- 1 Kilogram = 1,000 Grams = 2.2 lb.
- 1 Metric Ton = 1,000 Kilograms = 1 Megagram = 1.1 Short Tons

APPROXIMATE CONVERSION FACTORS

TO CHANGE	TO	MULTIPLY BY
Inches	Centimeters	2.540
Feet	Meters	0.305
Yards	Meters	0.914
Miles	Kilometers	1.609
Square Inches	Square Centimeters	6.451
Square Feet	Square Meters	0.093
Square Yards	Square Meters	0.836
Square Miles	Square Kilometers	2.590
Acres	Square Hectometers	0.405
Cubic Feet	Cubic Meters	0.028
Cubic Yards	Cubic Meters	0.765
Fluid Ounces	Milliliters	29.573
Pints	Liters	0.473
Quarts	Liters	0.946
Gallons	Liters	3.785
Ounces	Grams	28.349
Pounds	Kilograms	0.454
Short Tons	Metric Tons	0.907
Pound-Feet	Newton-Meters	1.356
Pounds Per Square Inch	Kilopascals	6.895
Miles Per Gallon	Kilometers Per Liter	0.425
Miles Per Hour	Kilometers Per Hour	1.609
TO CHANGE	TO	MULTIPLY BY
Centimeters	Inches	0.394
Meters	Feet	3.280
Meters	Yards	1.094
Kilometers	Miles	0.621
Square Centimeters	Square Inches	0.155
Square Meters	Square Feet	10.764
Square Meters	Square Yards	1.196
Square Kilometers	Square Miles	0.386
Square Hectometers	Acres	2.471
Cubic Meters	Cubic Feet	35.315
Cubic Meters	Cubic Yards	1.308
Milliliters	Fluid Ounces	0.034
Liters	Pints	2.113
Liters	Quarts	1.057
Liters	Gallons	0.264
Grams	Ounces	0.035
Kilograms	Pounds	2.205
Metric Tons	Short Tons	1.102
Newton-Meters	Pound-Feet	0.738
Kilopascals	Pounds Per Square Inch	0.145
Kilometers Per Liter	Miles Per Gallon	2.354
Kilometers Per Hour	Miles Per Hour	0.621

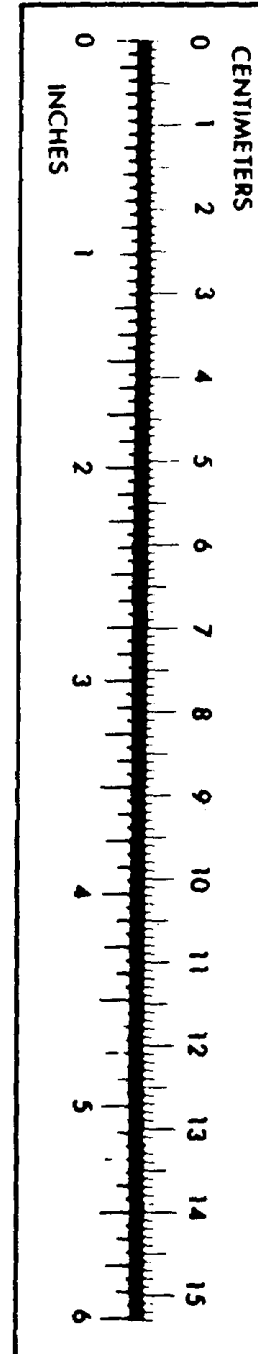

PIN: 069814-001